

HELI



**OPERATION &
MAINTENANCE MANUAL**

**H3 Series Counterbalanced Type
Forklift Truck with Engine**

1-3.5t

Foreword

1.1 Application Scope and Instruction on the Manual

- The manual contains the following contents: proper operation, easy maintenance and daily check;
- Before operation, please read the manual thoroughly to guarantee safe and effective material handling through proper operation and maintenance;
- Actual condition may be different from the description in the manual because of product improvement;
- The manual should be attached to the truck when lending or transferring the truck;
- If you have any questions, please consult with the sales department of our company;
- Instructions with  or  mark are very important to your and others safety, Please keep to them.

The OPERATION & MAINTENANCE MANUAL is delivered to you along with the truck. If there is no manual, please contact with local agent or dealer.

1.2 Safety signal, expression and mark

1.2.1

It indicates an imminently hazardous situation which, if not avoided, will result in death or serious injury. You must observe this instruction.



DANGER

1.2.2

It indicates a potentially hazardous situation which, if not avoided, could result in death or serious injury. You must observe this instruction.



WARNING

1.2.3

It indicates a potentially hazardous situation which, if not avoided, could result in minor or moderate injury. You must observe this instruction.



CAUTION

1.2.4

It indicates a statement of directly or indirectly related to the safety of personal and maintenance of the truck.



NOTE

1.3 Applied model

The manual is suitable for the following models:

- CPCD10~18-WS1H assembled with ISUZU GK-C240NKFC01 engine (meeting Euro III A and China III)
- CPCD10~18-QC1H assembled with Quanchai 4B4-45V32 (485) engine (meeting China III)
- CPCD10~18-XC4H assembled Xinchang 4N23G31 (485) engine (meeting China III)
- CPCD10~18-XC6H assembled with Xinchang 4N23G31-200 485 engine (VE pump) (meeting China III)
- CP(Q)(Y)D10~18-RC2H assembled with Nissan K21 engine
- CP(Q)(Y)D10~18-RC1H assembled with Nissan K15 engine (non-certificated type)
- CPC(D)10~35-HJ2H assembled Jiangling HJ493 engine (meeting Euro IIIA)
- CPCD10~35-KU11H assembled with V2403 engine(meeting Euro III and Tier IV)
- CPCD20~35-CU4H assembled with Cummins QSF2.8 engine (meeting Euro IIIA and Tier IV)
- CP(Q)(Y)D20~35-TY5H assembled with GM3.0 engine(meeting CARB IV)
- CPC(D)20~35-Q10H assembled with Quanchai4C3-60C31 engine (meeting China III)
- CP(Q)YD20~35-M1H assembled with Mitsubishi-4G64 (PSI) engine (meeting CARB IV)
- CPC (D) 20~35-M3H assembled with SPC-S4S-455 (meeting Euro IIIA, China III)
- CPCD20 ~35-CU5H assembled with QSF2.8(43kw) engine (meeting Euro IIIA and China III)
- CPC(D)20~35-WS1H assembled with ISUZU GK-C240NKFC01 engine(meeting Euro IIIA and China III)
- CPC(D)20~35-D2H assembled with Dachai CA498-97 engine (meeting China II)
- CPC(D)20~35-HJH assembled Jiangling HJ493 engine (meeting China II)
- CPC(D)20,25,30-W8H assembled with ISUZU 4JG2PE-01 engine (meeting China II)
- CPC(D)35-W4H assembled with ISUZU 4JG2PE-01 engine (meeting China II)
- CPQ(D)20~35-RCH assembled with Nissan K21 engine
- CPQ(D)20~35-RC1H assembled with Nissan K25 engine
- CPY(D)20~35-RCH assembled with Nissan K21 engine
- CPY(D)20~35-RC1H assembled with Nissan K25 engine
- CPQY(D) 20~35-RCH assembled with Nissan K21 engine
- CPQY(D) 20~35-RC1H assembled with Nissan K25 engine
- CPC(D) 20~35-W15H assembled with ISUZU GK-4GJ2NKFC01 engine (meeting Euro IIIA and China III)
- CPC(D) 20~35-D3H assembled with Dachai CA498-06T3R-A122 engine (meeting China III)
- CPC(D) 20~35-XC17H assembled with Xinchang 4D32XG30 engine (meeting China III)
- CPC (D) 20~35-KU14H assembled with Kubota V2403 engine (meeting Tier IV and Euro IIIB)

1.4 Truck general view

1.4.1 Truck application

It is mainly used for load carrying.

1.4.2 Direction affirming

Direction in this manual is affirmed from the operator's seat.

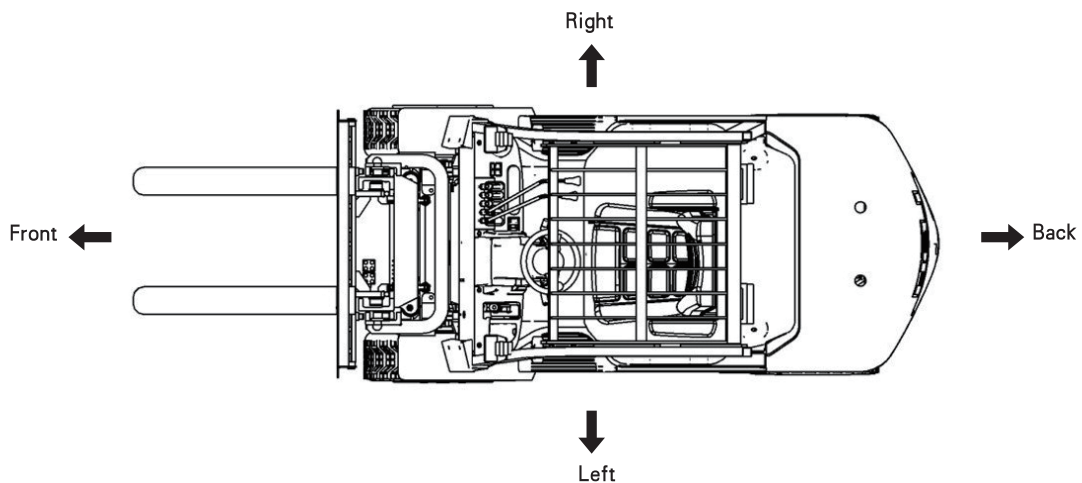

1.5 Measuring unit

The measuring units used in the manual are international system units.

1.6 Operation certification

WARNING

The truck can only be operated by trained and authorized person, or serious injury or death may be caused by operation by unqualified person.

1.7 Notes on new truck usage

1.7.1 Running-in of new truck

- Though the truck has experienced thoroughly adjust and test before delivery, the truck need moderate operation in the first month (200 hours) until all parts of the truck have full running-in time.
 - If the new truck works at bad environment at very first, the service life of the truck will be shortened and the performance will experience bad impact.
 - Pay attention to the following when the truck is run-in:
 - Keep the engine running at idle speed for 5 minutes after the engine is started;
 - Do not operate the truck when the truck is heavy loaded or travelling with high speed;
 - Avoid sudden start, acceleration, brake or sharp turning.
-

1.7.2 Maintenance of the new truck

The new truck needs oil changing, oil filter cleaning and bolts and nuts retightening during the first month usage (200 hours). Heli vehicles are to be maintained by HELI dealers.

1.8 Quality guarantee and maintenance

1.8.1 Parts changing at regular time

Heli truck requires parts changing at regular time except for the legal rules. Parts which are important for safety will inescapably go bad if they exceed their service time, so whether the parts are damaged, change according to regulated time. Refer to 4.1.4 CHECK AND MAINTENANCE TABLE for the key parts changing.

1.8.2 Usage of HELI specified parts and oil

Problem caused by the usage of non heli specified parts (including oil) are not covered by our warranty.

1.9 Basic information of the truck

Please offer HELI dealer or agent the basic information of the truck such as model, truck number, engine series number, accessories, optional devices and so on when maintaining truck or ordering parts.

1.9.1 Truck basic information table (complete by HELI dealer or agent)

Model	
Truck number	
Engine series number	
Accessories, optional devices	
Dealer/agent	
Address	
Telephone number, fax number	
Service person	
Sales person	

1.9.2 Displaying position of the truck model and number

The truck model and number is displayed on the truck plate which is on the right side of the engine hood.

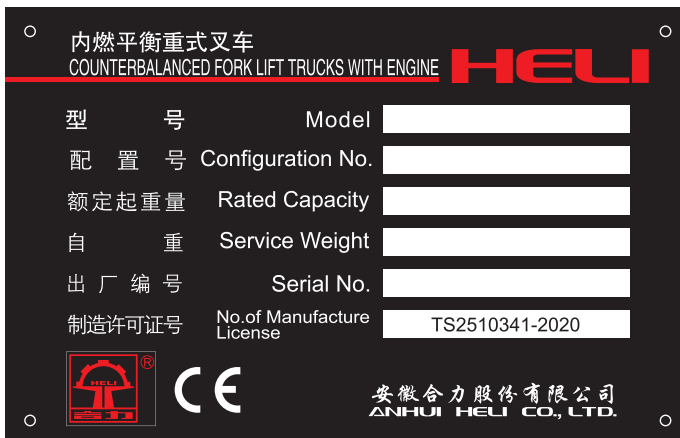
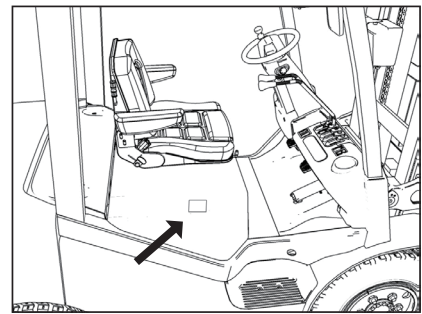

Model description

Truck information

Brand information

Model description shows the classification of industrial truck and manufacturer. Truck information includes truck type, rated lifting capacity, service weight (including oil and water, excluding fuel oil), serial number, and manufacture license number. Pay attention that the rated lifting capacity refers to the capacity of the truck with standard mast, standard fork and 500mm load center and without any attachments. Brand information includes manufacturer and whether the product meets Europe CE certification.

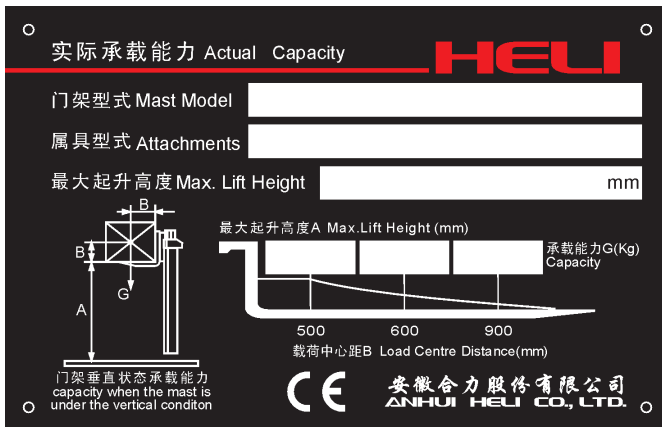

→ Mast information

Mast information consists the truck model assembled with the mast, mast type and height (M stands for two stage basic type mast, ZM standards for full-free two stage mast, ZSM stands for the full free three stage mast. The unit is cm.) Attachments consist types of side shifter, rotator, bale clamps and so on. Please refer to the attachments manual for more details such as model and function. Actual load capacity plate is shown in the figure. Capacity which is different from the rated lifting capacity stands for the capacity with attachments fixed. Because the service weight of the attachments and the moving forward of the load center, the capacity is lower than the rated capacity.

The truck number is also shown on the external plate of the truck.

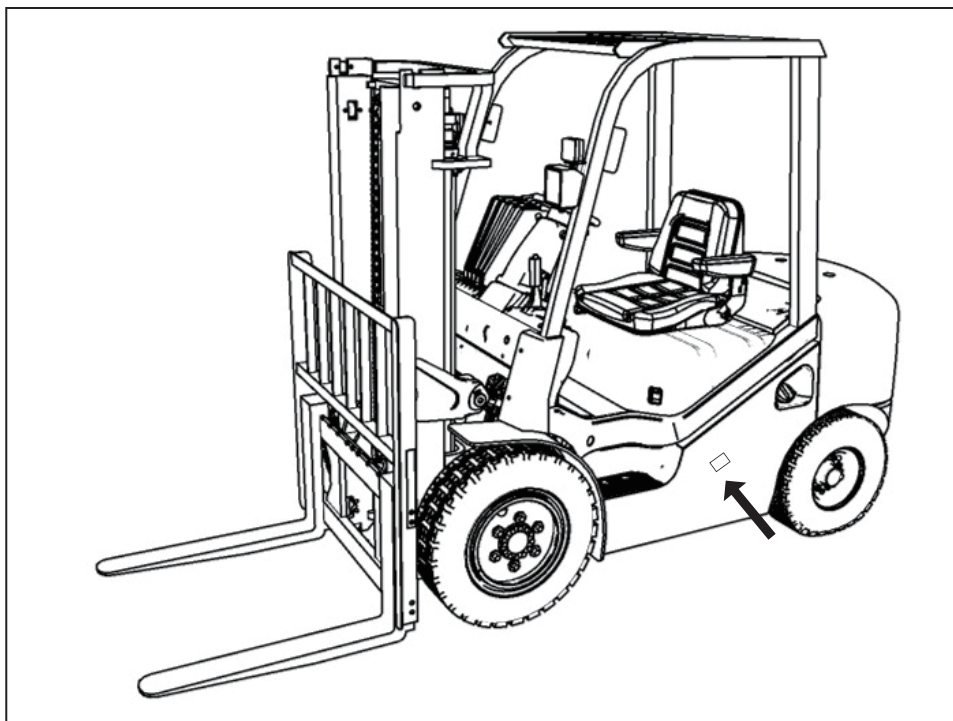

1.9.3 Displaying position of the truck working hours

It is in the middle of the meter.

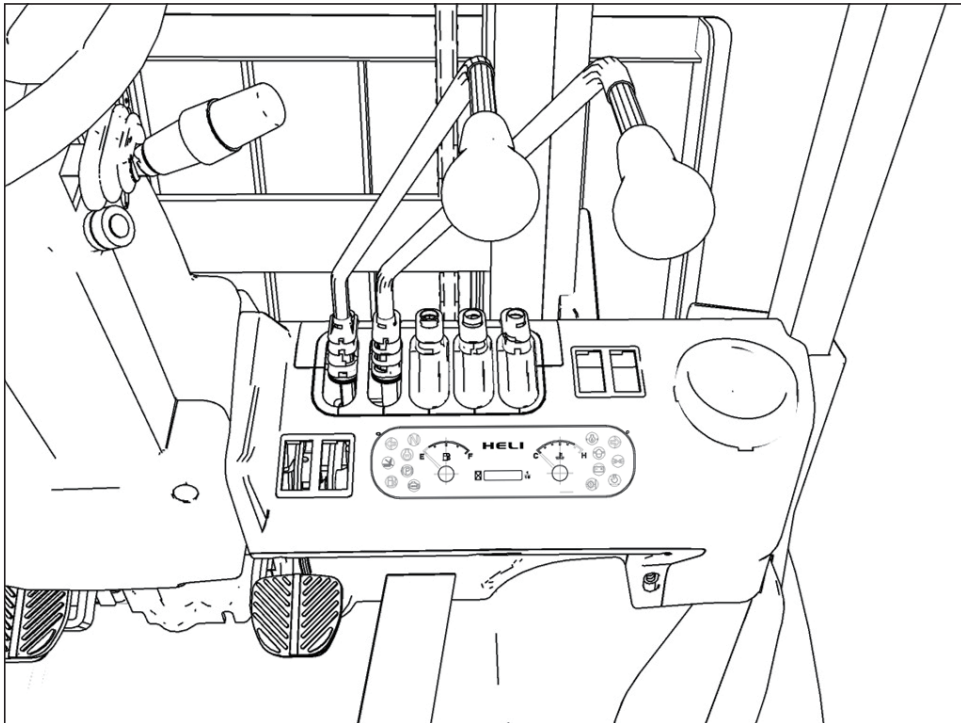

CONTENTS

FOREWORD 01

1.1 Application Scope and Instruction on the Manual.....	1
1.2 Safety signal, expression and mark.....	2
1.3 Applied mode.....	3
1.4 Truck general view.....	4
1.4.1 Truck application.....	4
1.4.2 Direction affirming.....	4
1.5 Measuring unit.....	4
1.6 Operation certification.....	4
1.7 Notes on new truck usage.....	5
1.7.1 Running-in of new truck.....	5
1.7.2 Maintenance of the new truck.....	5
1.8 Quality guarantee and maintenance.....	5
1.8.1 Parts changing at regular time.....	5
1.8.2 Usage of HELI specified parts and oil.....	5
1.9 Basic information of the truck.....	5
1.9.1 Truck basic information table.....	6
1.9.2 Displaying position of the truck model and number.....	6
1.9.3 Displaying position of the truck working hour.....	8

CONTENTS 09

SAFETY NOTES 15

2.1 Description of the safety plate.....	16
2.1.1 Position of the safety plates.....	16
2.1.2 Safety plates.....	17
2.2 Protecting against fire.....	20
2.2.1 Protect engine against fire.....	20
2.2.2 Protecting against fire caused by fuel or oil.....	22

2.2.3	Protect against fire caused by adhered flammable things.....	22
2.2.4	Protect against fire caused by wire fault.....	22
2.2.5	Protect against fire caused by oil pipe fault.....	22
2.2.6	Cleaning after operation.....	23
2.2.7	If fire occurs.....	24
2.3	Basic notes.....	24
2.3.1	Follow the rules.....	24
2.3.2	Do not operate fault truck.....	24
2.3.3	Proper wearing when operation	25
2.3.4	Fire extinguisher and first-aid kit.....	25
2.3.5	Note on the safety devices.....	25
2.3.6	Practice before operation.....	25
2.3.7	It is prohibited to jump on and off the truck.....	26
2.3.8	Keep the driver's cab clean and tidy.....	26
2.3.9	Notes when flushing truck	26
2.3.10	Beware of scalding.....	27
2.3.11	Protection against fire.....	27
2.3.12	If fire occurs.....	28
2.3.13	Do not modify the truck.....	28
2.3.14	Do not disassemble overhead guard and backrest.....	28
2.3.15	Ensure the working area safety.....	29
2.3.16	Beware of the engine exhausting.....	29
2.3.17	Note on window washing solution.....	29
2.3.18	No welding.....	29
2.4	Before operation.....	30
2.4.1	Starting check.....	30
2.4.2	Check and adjust before starting.....	30
2.4.3	Starting check.....	30
2.5	Travelling.....	31
2.5.1	Preparation before travelling	31
2.5.2	Notes when travelling.....	32
2.5.3	Notes on truck stopping and parking.....	37
2.5.4	Notes on towing.....	38
2.6	Load carrying operation.....	38
2.7	Check and maintenance notes.....	44

2.7.1 Be sure to carry out the starting check.....	44
2.7.2 Place a warning sign around during check and maintenance.....	44
2.7.3 Keep the working area clean and tidy.....	45
2.7.4 Notes before check and maintenance.....	45
2.7.5 Let the unauthorized people be away.....	45
2.7.6 Proper using of the tools and devices.....	45
2.7.7 Notes when working under the working devices.....	46
2.7.8 Beware not to be caught by mast or falling.....	46
2.7.9 Beware of the boiling cooling liquid.....	47
2.7.10 Take care of the high pressure oil.....	47
2.7.11 Beware of the rotating belt and fan.....	48
2.7.12 Notes when repairing electric system.....	48
2.7.13 Notes when cleaning with compressed air.....	48
2.7.14 Notes when dealing with battery.....	49
2.7.15 Follow the rules strictly so as to avoid spark.....	49
2.7.16 Note when installing or removing the battery.....	50
2.7.17 Note when dealing with the tyres.....	50
2.7.18 Note when dealing with the waste.....	51
2.7.19 Notes after check and repair.....	51
2.7.20 Regular check on the key parts.....	51
2.8 Transportation and hanging up	52
2.8.1 Notes when hanging up truck.....	52
2.8.2 Notes when loading or unloading the truck.....	52
2.9 Truck structure and stability.....	53
2.9.1 Longitudinal stability.....	53
2.9.2 Load center of gravity.....	53
2.9.3 Combined center of gravity and loaded truck stability.....	53
2.9.4 Actual loading capacity	54
2.9.5 Instruction on the capacity chart.....	54
2.9.6 Instruction on safety devices choice.....	55
2.10 Towing.....	56

OPERATON

57

3.1 General view.....	58
3.1.1 Truck general view.....	58

3.1.2 Instrument and control devices.....	59
3.2 Parts instruction.....	60
3.2.1 Meter.....	60
3.2.2 Operating devices.....	64
3.2.3 Assembly and disassembly of the attachments.....	68
3.3 Operation.....	70
3.3.1 Starting check.....	70
3.3.2 Getting on and off the truck and operation posture adjusting.....	70
3.3.3 Starting, gear shifting and travelling.....	73
3.3.4 Start and stop on a slope.....	78
3.3.5 Inching.....	79
3.3.6 Steering.....	79
3.3.7 Operate on snow field and icy field.....	80
3.3.8 Truck deceleration and braking.....	80
3.3.9 Load handing operation.....	81
3.3.10 Notes when the truck is equipped with solid tyre.....	83
3.3.11 Check after operation.....	83
3.4 Transporting.....	84
3.4.1 Truck fixing.....	84
3.4.2 Mast transporting and reassembling.....	86

CHECKING AND MAINTENANCE

88

4.1 About checking and maintenance.....	89
4.2 Starting checking.....	89
4.2.1 Check the abnormal found the day before.....	91
4.2.2 Forklift truck.....	91
4.2.3 Open the engine hood to check.....	94
4.2.4 Check sitting on the chair.....	97
4.2.5 Check when the starting key switch is on ON position.....	99
4.2.6 Check when the engine is started.....	102
4.2.7 Check when travelling slowly.....	103
4.2.8 Check through operating the working devices operation lever.....	103
4.2.9 Safety function check.....	105
4.3 Check after operation and report.....	106

4.4 Simple maintenance.....	107
4.4.1 Lubricating grease and fuel.....	107
4.4.1.1 Notes.....	107
4.4.1.2 Lubricating chart.....	109
4.4.2 Filter element cleaning.....	111
4.4.3 Water and gas exhausting of the fuel filter (diesel engine)	111
4.4.4 Tyre changing	112
4.4.5 Parking brake shank operation force adjusting	114
4.4.6 Fuse changing.....	115
4.4.7 Bulbs changing.....	118
4.5 Steps of dealing with the fault battery.....	119
4.6 Working in cold weather.....	121
4.7 Measures for engine over heating.....	122
4.8 Operate truck in special environment or with force.....	123
4.9 Measures if the fork can not be lowered.....	124
4.10 Truck cleaning.....	125
4.11 Storing for a long time	126
4.12 slinging the truck	127
4.13 Loading and unloading the truck.....	128
4.14 Check and maintenance time table	129
4.15 Change the safety key parts regularly.....	139
4.16 Repair parameter (gasoline engine).....	140

OPTIONAL

141



SAFETY NOTES



WARNING

Please read the manual and safety notes carefully.

When operating the truck, please follow the safety notes or serious injuries may be caused.

2.1 Description of the safety plate

2.1.1 Position of the safety plates

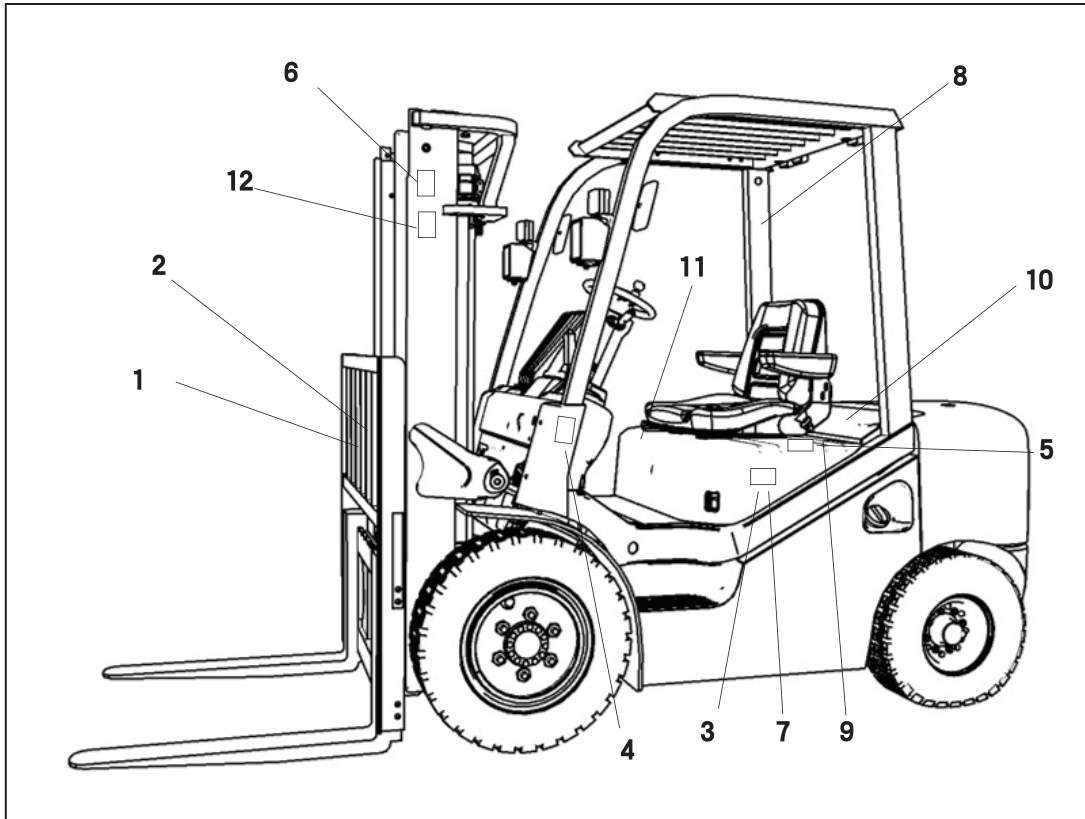

Safety plate		Position
1	Mind your hands	The rear side of the tilting cylinder mast pillar and top pillar (the middle cross beam of the external mast)
2	Do not enter the space after the mast	The rear side of the tilting cylinder mast pillar and top pillar (the middle cross beam of the external mast)
3	Battery maintenance notes	In the middle of the battery external side
4	Tyre safety plate	The outside lower side of the overhead guard front leg
5	Checking points before starting (if there is no the plate, please refer to the usage notes)	The left side of the engine hood surface
6	Sling plate	The right and left side of the external mast
7	Gas spring safe lock	The outside of the left engine hood
8	No flushing water	The outside of the overhead guard right rear leg
9	Fan safety plate	The top of the radiator's wind cover
10	Aluminum radiator warning plate	the radiator's cover
11	Usage note	Right side of the engine hood
12	Safety plate	The right and left side of the external mast
13	Safety belt	The left side of the engine hood surface

2.1.2 Safety plates

- (1) Caution: mind your hands
 - Do not put your hands where may be caught.

- (2) No jump starting
 - Start the engine only when the operator sit well on the seat;
 - Never try to make the engine starting circuit short circuit on purpose to start the engine, or serious injury or fire may be caused.

- (3) Notes when dealing with battery
 - The shape and layout may vary from different battery suppliers.
 - Do according to the battery maintenance note during usage.

- (4) Tyre safety
 - Before assembling and disassembling, please read the tyre safety plate carefully.
 - The tyre pressure should not exceed the regulated value.

- (5) It is prohibited to enter the space between mast and frame.
 - It is prohibited to enter the space between mast and frame.

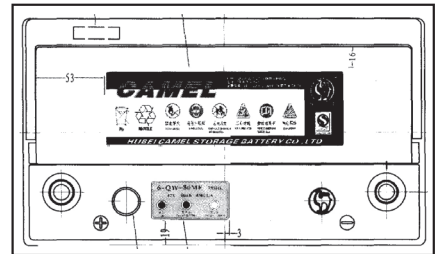

■ (6) Notes when slinging

- Never sling the truck at the overhead guard top cover.
- Sling the truck at the shown positions.

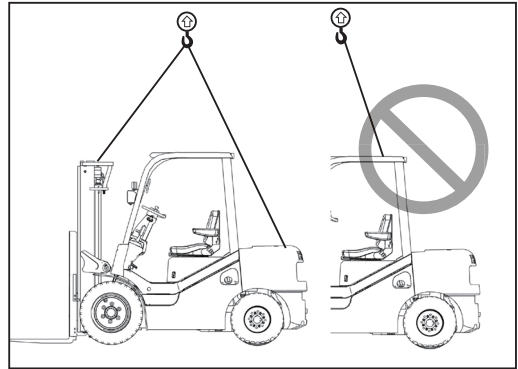

■(7) Safe usage of the gas spring

- Please press the gas spring safe lock button before shut off the engine hood.

■(8) Truck washing notes

- Do not flush the electric parts such as cabinet, sensors, connectors and so on.
- It is prohibited to flush the air intake cover of the overhead guard.

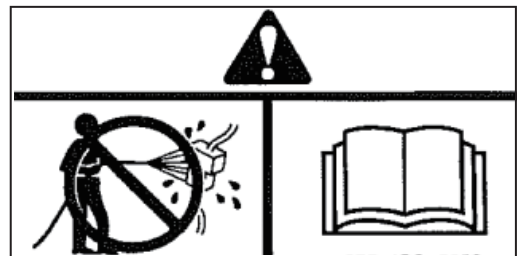

■ (9) Be care of cut

- Keep your hand away from the working fan.

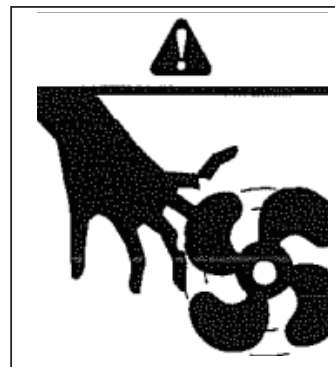

■ (10) Use the radiator with care

- Rotate the radiator cap slowly until the coolant is cool.



■ (11) Notes before operation

- **WARNING:** Read the **OPERATION AND MAINTENANCE MANUAL** carefully before operation, maintenance, disassembling and assembling.
- Read the usage note plate to avoid improper operation.
- Check the truck before starting according to the checking points before starting. (if there is no the plate, please refer to the usage notes.)

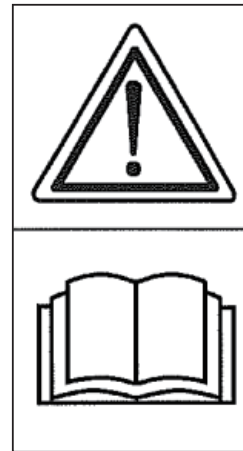

■ (12) It is prohibited to stay at the area above or below the fork.

- Do not enter the area below the fork.
- Do not stay on the fork.



■ (13) Take care of truck tipping over

- Before operation:
 1. Wear safety belt when operating;
 2. Be sure to read and understand what is said in **OPERATION AND MAINTENANCE MANUAL**;
- If there is a possibility of tipping over during operation
 1. Do not jump off the truck;
 2. Body incline opposite the truck tipping over direction;
 3. Grasp the steering wheel tightly;
 4. Support your body with two feet.

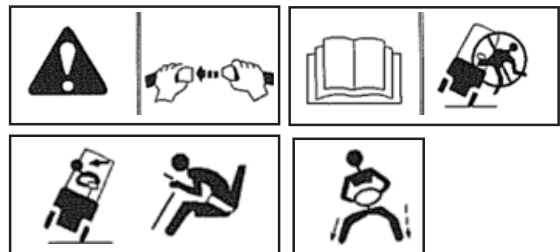

■ (14) Operate with proper posture (only hydraulic-powered transmission truck with OPS)

- If the truck is operated with such posture (the seat does not bear your whole weight, for example stand or lean against forward, backward or side when operating), the power will be cut for 3 seconds and in that case, the truck will not travel or operate.

It is very dangerous to operate like this when travelling on a slope. The truck will slide down even acceleration pedal is pressed because the power is cut. Accident such as collision or falling will occur.



2.2 Protecting against fire

2.2.1 Protect engine against fire

Before starting the engine, check the following parts: if the battery terminal is loose, fix it. And if there is dirt such as smudginess, leaf or paper, remove it.

If problems still exist, contact with HELI dealer for repair.

- 1. Check around engine
 - Check if there is any leaves or paper around engine;
 - Check if there is engine oil or fuel leakage around engine;
 - Check if the muffler and air exhaust pipe are well;

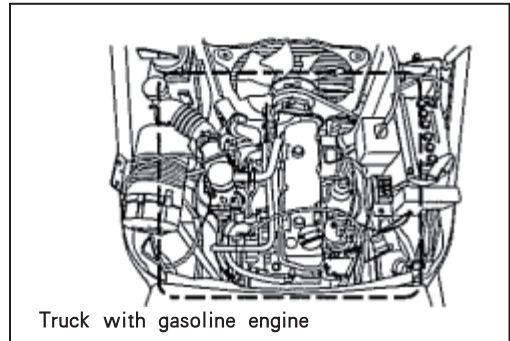

- Check if the wire and wire clamps are loose or damage.

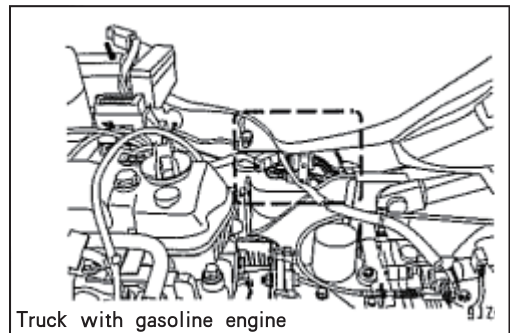

- 2. Check around the battery
 - Check if the battery terminal, contactors or wire clamps are loose or rust;
 - Check is there are leaves, paper or metal around battery;
 - Check if the cables or harness are damaged.

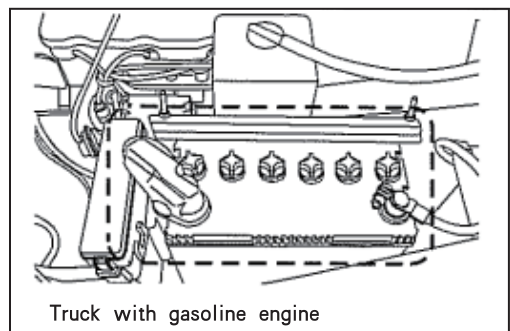

■3. Check if oil or fuel leaks.

- Check if the pipes or fuel tank (1 shown in the figure) leak;

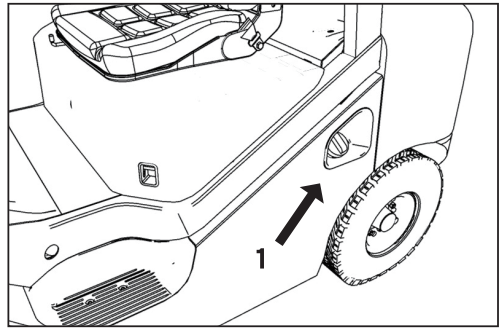

- Check if there are leaves or paper around fuel tank or hydraulic oil tank;

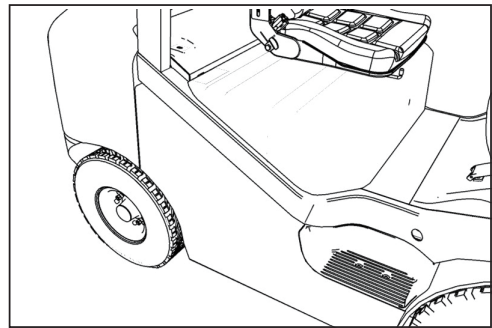

- Check if there are dirt gathering under the truck chassis (engine or transmission system), especially the truck with floor board.

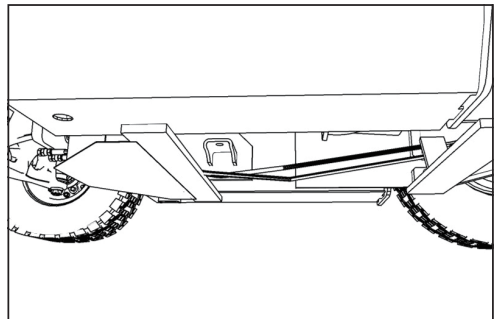

■4. Check the inside of the driver's cab.

- Check if there are cigarettes or other flammable things in the driver's cab.

2.2.2 Protecting against fire caused by fuel or oil

■ Keep the fuel, oil, cooling liquid and window washing solution which are flammable away from the open flame. Obey the following instruction in actual operation;

- Do not smoke or keep the fire near the fuel, oil, cooling liquid or wind washing solution and clothes sucked with these liquid;
- Shut off the engine before fuel adding;
- Do not go away when oil or fuel adding;
- Tighten the oil adding cap;
- Do not let the fuel run out onto the hot surface or electric parts;
- Keep the fuel and oil in well ventilated shaded place;
- Keep the fuel and oil in specified place away from people;
- Remove the spilled fuel, oil and grease after oil adding;
- Keep the clothes sucked with oil and other flammable things in a safe container and store in a specified safe place;
- When checking or maintaining the truck with devices and equipments, take care and protection measures of the fire caused by spark or flame.

Serious injuries or death will be caused if these safety measures are not obeyed.

2.2.3 Protect against fire caused by adhered flammable things

■ Adhering or blocking of flammable thing around engine air exhausting manifold, muffler, air exhausting pipe, battery and inside of floor board will cause fire. Remove these flammable things.

2.2.4 Protect against fire caused by wire fault

- Fire will be caused by short circuit of wire.
- Clean all wire contactors and fix them;
 - Check if the harness is loose, worn or damaged daily. Tighten the loose contactor and wire clamp. The damaged harness must be repaired or changed by HELI dealer.
-

2.2.5 Protect against fire caused by oil pipe fault

■ Be sure the snap clip, guard board and cushion pad are proper fixed. Loose pipe or hose may be damaged because of vibration or friction with other parts when operated and fire or injury may be caused by ejection of high pressure liquid.

2.2.6 Cleaning after operation

- Remove the dirt, leaves or paper with fan after operation.

- Around engine
Clean around air exhausting manifold.

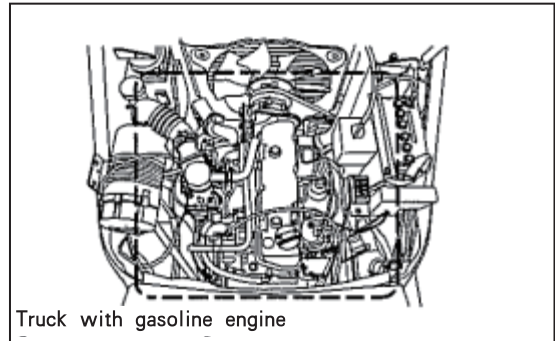

- The bottom of the chassis
Lay emphasis on the truck with bottom plate where dirt is easy to gather.

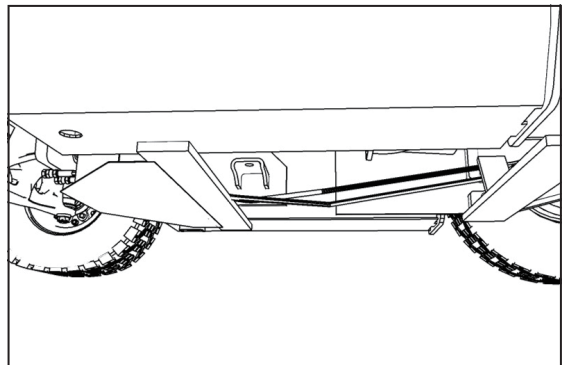

- Floor board

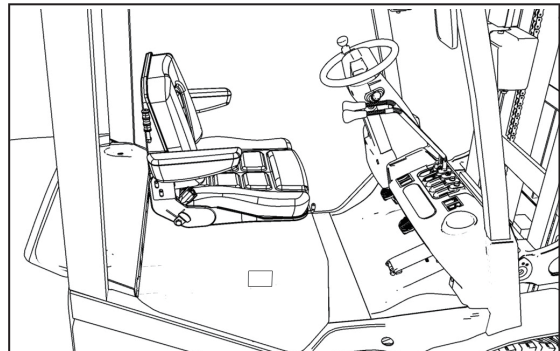

- Around the muffler

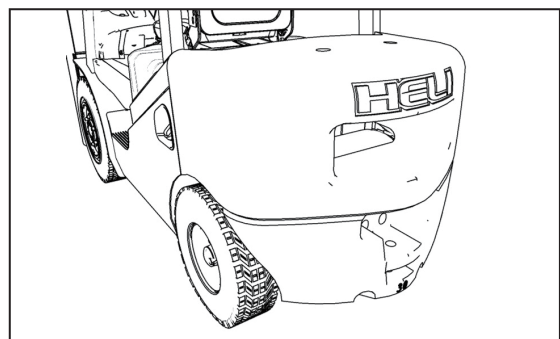

2.2.7 If fire occurs

- If fire occurs, turn the starting switch to OFF position to shut off engine.
- Do not jump off the truck in a hurry. Support yourself with handle and pedal in order to leave safely.

2.3 Basic notes

2.3.1 Follow the rules

- Only trained and authorized person can operate the truck.
- Fully understand and obey the OPERATION AND MAINTENANCE MANUAL.
- Do not operate the truck when you have tired, mix emotional problems, drugs or alcohol.
- Make a safety plan in advance.
 - Before operation, make operation plan according to the working environment, truck type, truck capacity and road condition.
 - Assign a towerman and operate according to his guide when travelling in a narrow place or loading or unloading big goods.
 - The main responsibility during operation is safety. Ensure the safety of yourself, truck, place around working and other property in the working area.

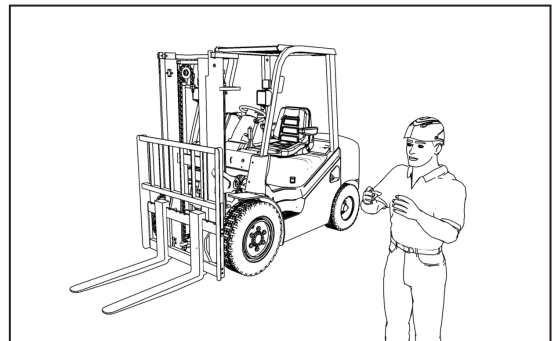

2.3.2 Do not operate fault truck

- If there is any abnormal during check or operation (such as noise, vibration, smell, abnormal of meter, smoking, miss-working of alarming device and monitor), report it to manager and take proper measures.
- Do not operate the truck until it is repaired.
- Remove the key from the fault truck and place a mark in the cab avoiding miss-using.
- If the truck with the fork lifted has to be stopped because of fault, place a mark on the fork and take measures preventing touch by pedestrian and truck.
- Place the truck where no person or truck will pass by avoiding person going under the fork.

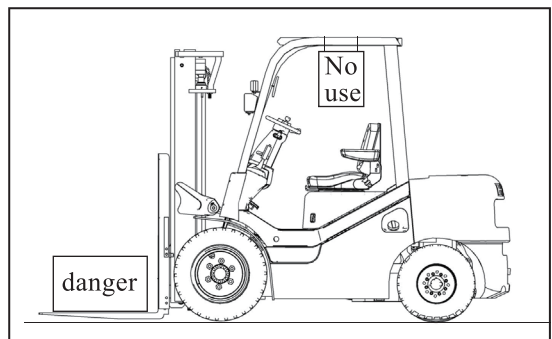

2.3.3 Proper wearing when operation

- Do not wear loose clothes and fittings. It is very dangerous if it is caught by control lever or other protrusions.
- Do up long hair or it may be caught by rotating parts.
- Wear safety cap and shoes. Wear equipments fits working condition or requirements.
- Before operation, check if the safety equipments are well.

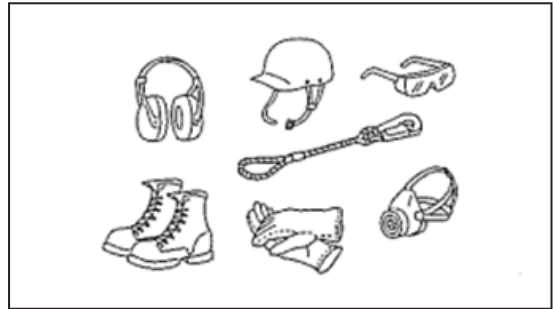

2.3.4 Fire extinguisher and first-aid kit

- Be aware of the position of fire extinguisher and first aid kit and know how to use then in case of fire or injury.

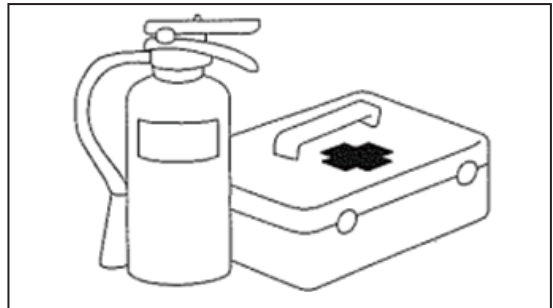

2.3.5 Note on the safety devices

- Check if the protection cover, shield and back mirror are proper fixed.
- Make sure you know the usage of safety devices fully.
- Do not disassemble the safety devices and make sure they are in good condition.
- If there is damage or loose of overhead guard or back rest, do not operate the truck until HELI dealer or agent fix it well.

2.3.6 Practice before operation

- Before operation, learn with enough time until all parts are familiar.
- Take care when driving even you are familiar with the truck or injuries or damage may occur.
- Truck even in same model has its own character in brake, accelerator and load handing device and so on. Before operation, be familiar with the truck if you change a new one. Take care when braking.

2.3.7 It is prohibited to jump on and off the truck

- It is prohibited to jump on and off the truck.
- Do not jump onto the truck to try to stop it when it moves accidentally without any operation.
- Get on or off the truck from the left side.
- Support yourself at least in three points with hand and foot when getting on or off the truck. Step on the step, grasp the handle with left hand and grip the seat back or seat when getting on and off.
- Do not grasp control lever and steering wheel when getting on or off the truck.

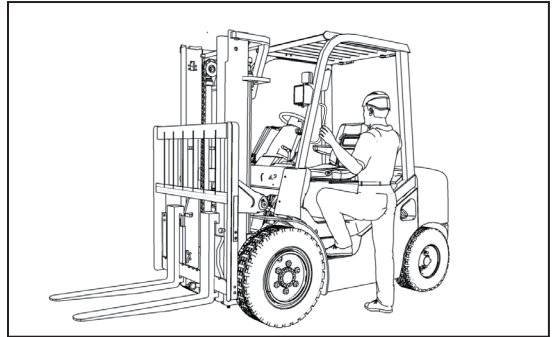

2.3.8 Keep the driver's cab clean and tidy

- Keep the drive's cab and area such as handle, step and floor board clean and tidy. Oil, mud, dust adhering around driver's cab or parts scattering around may cause slipping or fabric caught in which will cause accidental falling or miss-operation.

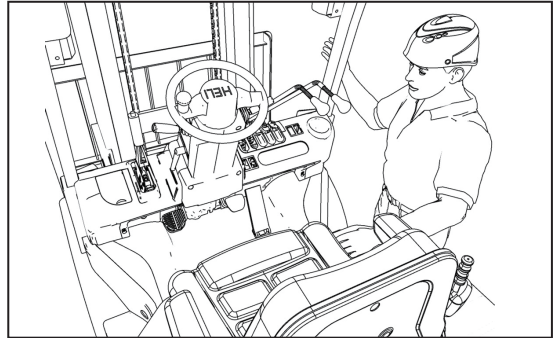

2.3.9 Notes when flushing truck

- Do not flush the electric parts (controller, sensor and contactor) or fault may occur. Or flush the truck with high pressure washer (steam washer).
- If it is electric controlled engine, it is prohibited to wash engine with flush water, or fault may occur because of water splashing onto electric units (such as ECU, sensor or connector).
- Combined instrument, engine and generator can not be washed with flushing water.

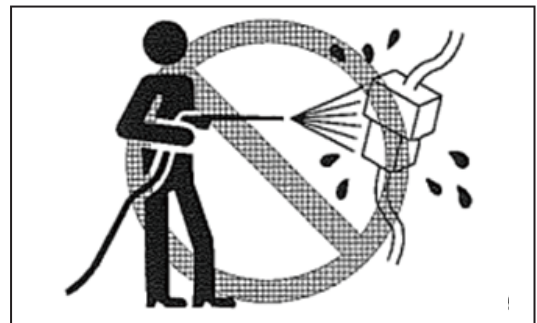

2.3.10 Beware of scalding

■ Cooling liquid with high temperature

- The cooling liquid is in high temperature if the truck is just stop. There is a danger of scalding caused by the ejecting of steam or boiling water if the radiator cap is removed at once. Remove the radiator cap slowly after the cooling liquid is cool.



■ Parts and oil with high temperature

- Check and maintain the truck until it is cool in order to preventing scalding by oil ejecting from the high temperature parts.



2.3.11 Protection against fire

- Protect against fire caused by fuel and oil;
- Protect against fire caused by adhered flammable things;
- Protect against fire caused by wire fault;
- Protect against fire caused by pipeline fault;



2.3.12 If fire occurs

- If fire occurs, turn the starting switch to OFF position to shut off engine.
- Do not jump off the truck in a hurry. Support yourself with handle and pedal in order to leave safely.

2.3.13 Do not modify the truck

- Contact with HELI sales and service agent before carrying out any modification (fix, disassembly and change) on the truck, accessories, optional parts because accidents or illegal occasion may happen.
- We are not responsible for any injuries, damages and accidents caused by unauthorized modify by HELI.

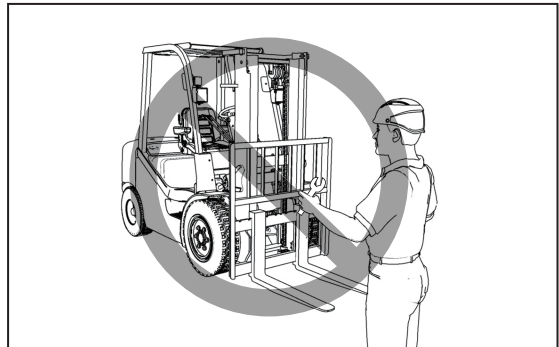

2.3.14 Do not disassemble overhead guard and backrest

- The overhead guard and backrest are used to protect operators against harm from falling goods. Do not disassemble overhead guard and backrest.
- Do not operate the truck without overhead guard and backrest.
- The overhead guard is made according to the safety standard, but it may not satisfy with any occasion. Beware of the harm caused by the falling goods.

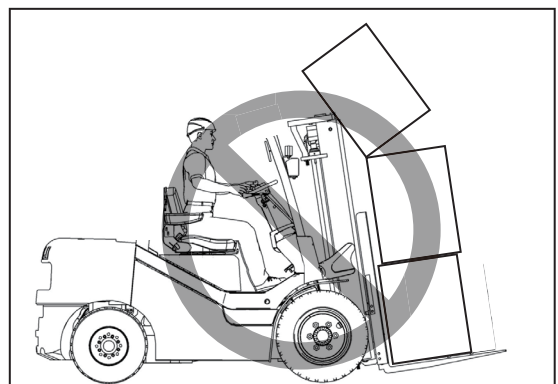

2.3.15 Ensure the working area safety

- Ensure the flatness of the road and working area and clean the oil and grease on the working area avoiding injury caused by bump and slip.
- When working in place that has a danger of falling such as dock, platform and so on, place blocks avoiding truck travelling surpassing boarder.
- Place a warning in dangerous place in working area to warn the drivers stay away.
- Identify the limit speed, temporary parking line and no entering of other vehicles and pedestrian and such plate clearly in working area.

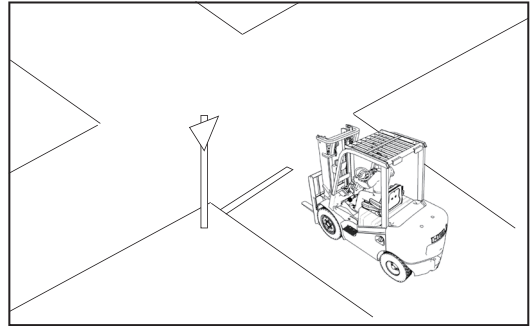
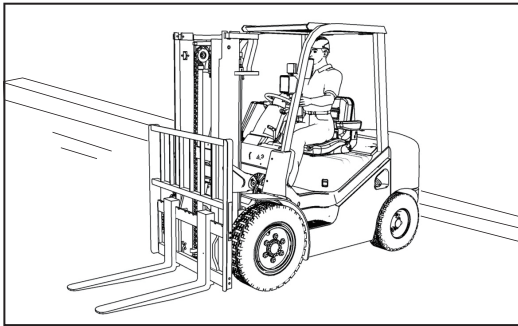

2.3.16 Beware of the engine exhausting

- The engine exhausting has carbon monoxide which is poison. Do not make the engine run all the time in poor ventilated place. Open the door and window to keep good ventilation.

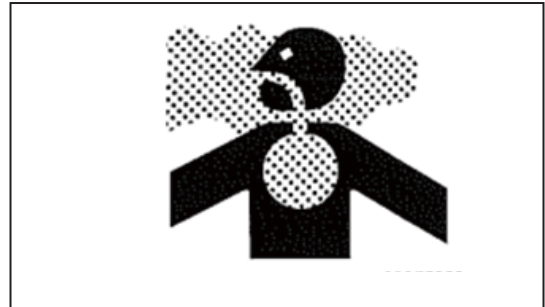

2.3.17 Note on window washing solution

- Do not use window washing solution with carbinol which is harmful for eye, but use washing solution with alcohol.

2.3.18 No welding

- If it electric controlled engine, it is prohibited to carry out welding work on the truck. if it has to, weld after dismount the ECU.
- All parts of the fork are not allowed to be welded. If welding is required, it must be carried out according to the specified welding process.

2.4 Before operatio

2.4.1 Starting check

Carry out starting check every day in order to ensure truck safe operation. Refer to “check and maintenance” for the detailed check item.

2.4.2 Check and adjust before starting

- Check the following item before starting
 - Check the lever of cooling liquid, fuel and engine oil. Check if air cleaner is blocked.
 - Adjust seat (seat position, back angle), steering wheel and back mirror. Make sure all lock devices are locked.

- Note when starting engine
 - Before starting, check if the parking brake is applied and operation levers (forward/backward and high/low speed lever) are in neutral position;
 - Before starting, sound the horn to warn around;When starting, check if it is safe around and sit on driver’s seat;

Never try to make the engine starting circuit short circuit on purpose to start the engine, or serious injury or fire may be caused. Do not start the engine through pushing the truck;

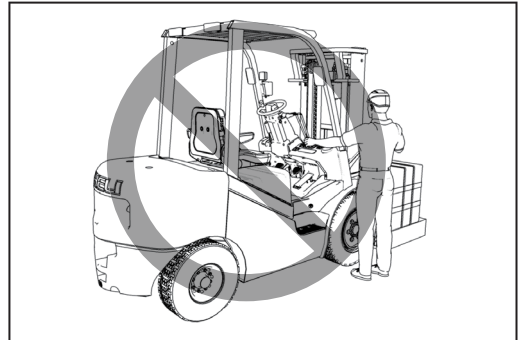

- Notes in cold weather
 - Make the engine warm completely in cold weather, or the truck may move slowly or change direction suddenly which may cause accident.



2.4.3 Starting check

- Check the working condition of the meter especially the alarm light;
 - The indicators on the meter turn on after the key switch is turned on. After 3 seconds, the indicators turn on or off according to actual condition.
 - Make sure the operator presence sensing system work well;
 - If there is any abnormal such as noise, vibration, heating, smell, improper adjusting of meter, engine oil or fuel leakage, be sure to remove the faults before operation.

2.5 Travelling

2.5.1 Preparation before travelling

- Wear safety belt
 - Wear safety belt before operation;
 - Check if the safety belt is well;
 - Injury may occur if safety belt is improper fixed.

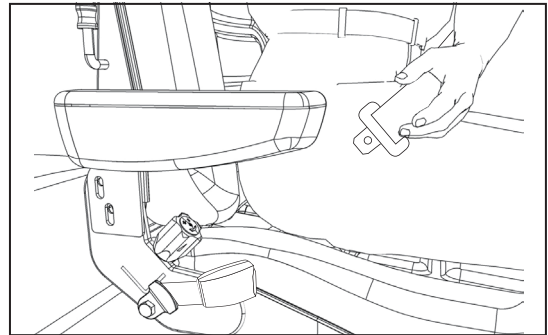

- Proper seat posture
 - If you operate the truck with improper seat posture or away from the seat, accident may occur.



- Standard operation posture
 - Do not put your hand and foot outside the overhead guard;
 - Keep your body under the overhead guard all the time.

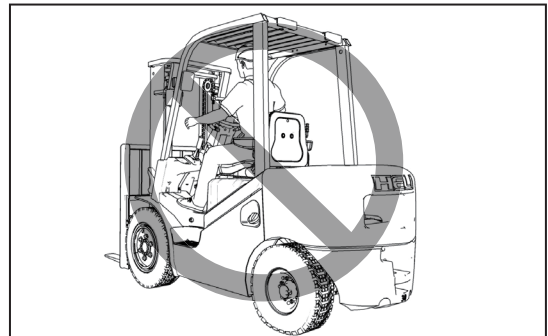

- Take care of the safety around before travelling;
 - Before travelling, check if there is any barrier around such as pedestrian, other vehicles or goods.
 - Lift the truck 15-20cm above and tilt back the mast;
 - Sound the horn if possible.

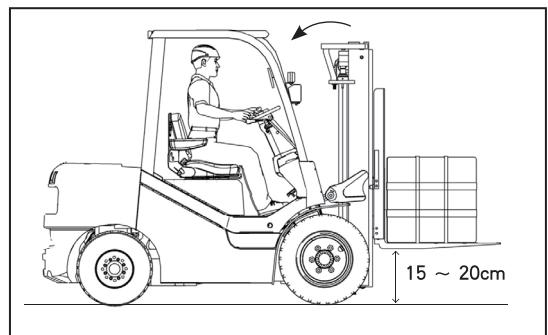

2.5.2 Notes when travelling

- Avoid sudden start, stop and direction change;
 - Stop truck (hydraulic-powered truck) before direction change;
 - Operate the operation lever (forward/backward lever, high speed/ low speed lever) after stepping on the clutch pedal fully only. (Mechanical truck)

- Keep safety in mind during travelling
 - Avoid sudden start, brake and sharp turning;
 - Keep the travelling road with good visibility;
 - Slow down and keep a safe distance with the passing truck when passing truck;
 - Comply with the regulated limit speed and keep a safe distance with the other truck;
 - Pay attention to the area around the truck especially the travelling direction or when steering;
 - Never try to overtake other trucks in narrow road or area with poor sight such as crossroad;
 - Stop to ensure the safety around and sound the horn if necessary when turning at crossroad or travelling into narrow road;
 - Even the horn is sounded, pay attention to the moving of people around;
 - Do not let people enter the working area;
 - Give way to the loaded truck on ramp or in narrow area.

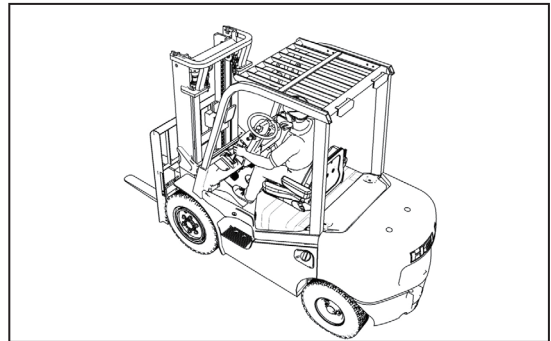

- Do not ride any people on the truck.
 - Do not ride any people on the truck at any case;
 - Do not ride people on the truck as a counter weight.

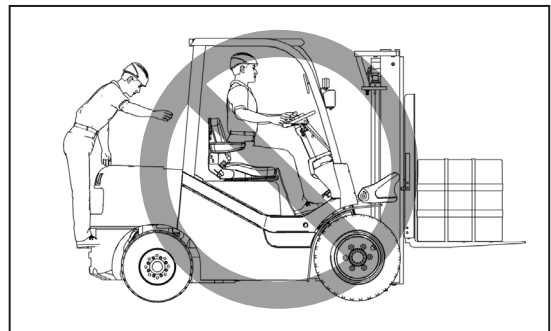

- Do not shut off the engine during travelling;
 - If starting key is turned to off position during travelling, the operation force on the powered steering will be increased and what is more accidents will be caused.

■ Do not stay your foot on the inching pedal (hydraulic-powered truck).

- Keep foot away from the inching pedal during normal travelling or the untimely worn out of the clutch and overheat of transmission unit;
- Brake unit will be ineffective if the pedal is pressed to haft engaged with the clutch.

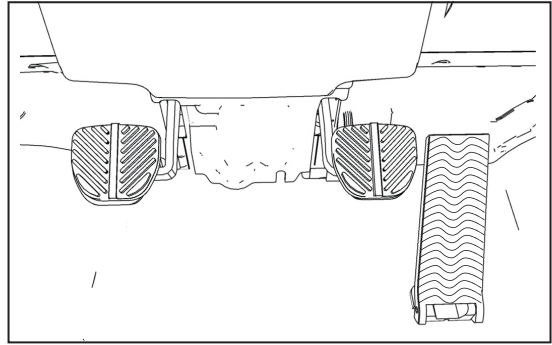

■ Take care to control the reversing direction when travelling backward.

- When travelling backward, check the back area visually. Do not depend on the backview mirror which is just an auxiliary device only completely when travelling backward.
- Take care if there is anybody backward even the horn is sounded.

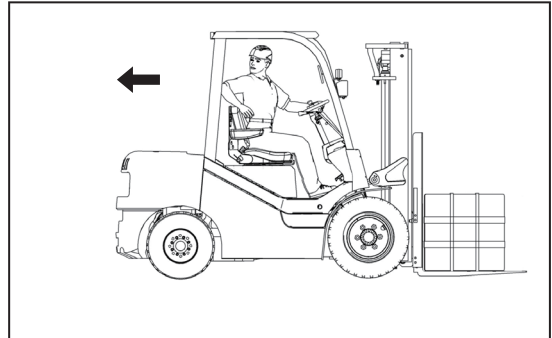

■ Assign a towerman or travel backward when carrying a load with huge size.

- Assign a towerman or travel backward if the front view is cut off in order to ensure the safety around;

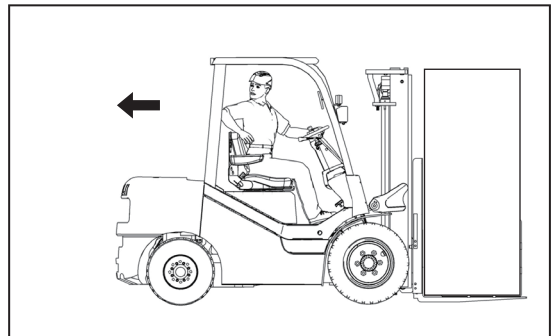

■ Take care of the backview for the truck with LPG container.

- Keep in mind that the truck with LPG container has poor backview which has a danger of collision of people around or goods. So make sure to check the back view;
- Contact with HELI agent or dealer for detail when alarming devices such as backward flasher, backward sensor, backview mirror and so on are needed.

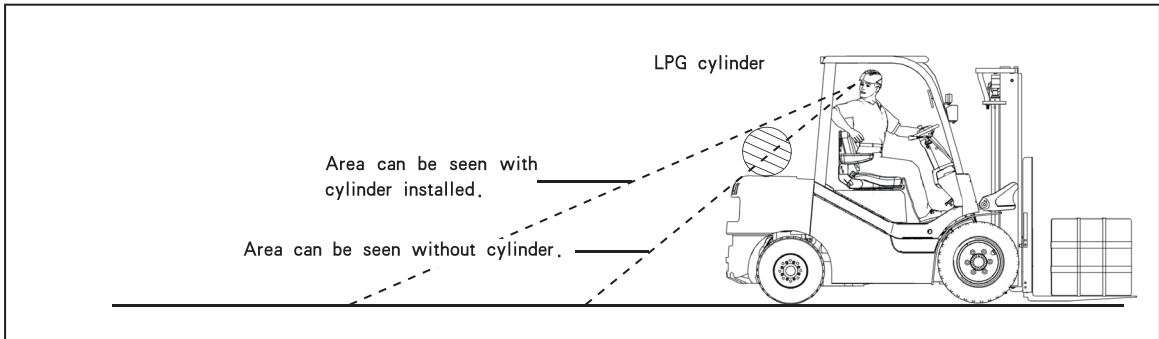

■ Avoid travel with goods lifted.

- The center of gravity will be lifted if there is loading device or lifted load. So there is a risk of tipping over. Do not travel with goods lifted. (lift the goods 15~20cm above and tilt back mast.)

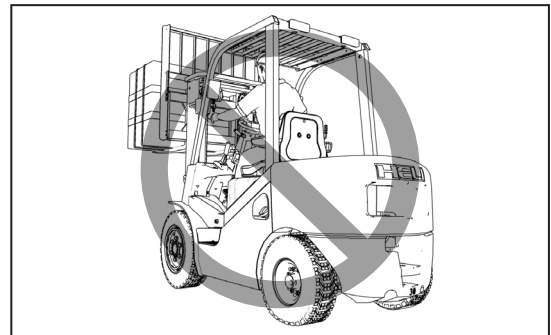

■ Do not jump off the truck when the truck is tipping over.

- Wear safety belt in case of truck tipping over;
- Read the OPERATION AND MAINTENANCE MANUAL carefully and operate, check and maintain properly in order to avoid accident such as truck tipping over;
- Do not jump off the truck if the truck tips over or serious injury may be caused by truck ;
- Body incline opposite the truck tipping over direction;
- Grasp the steering wheel tightly;
- Support your body with two feet.

Practice the actions below and ensure you know how to do in case of emergency.

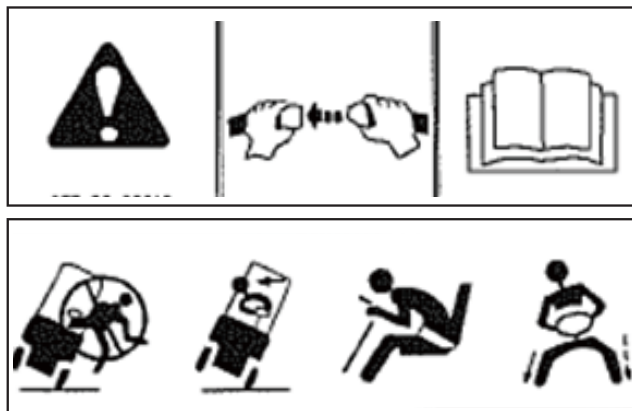

■ Beware of the rear part rotation;

- The steering wheel of the truck is its rear wheel which is different from the other kind of truck;
- Keep a safe distance with the wall because the counter weight will rotate outside when steering.

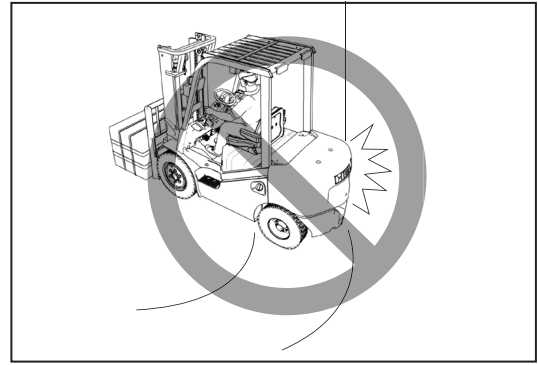

■ Pay attention to the max. height and width of the truck

- Make sure there is enough height and width when truck passing;
- Keep a safe distance with mast, harness and pipeline;
- Take care of the height of the mast and backrest when fork is lifted high.

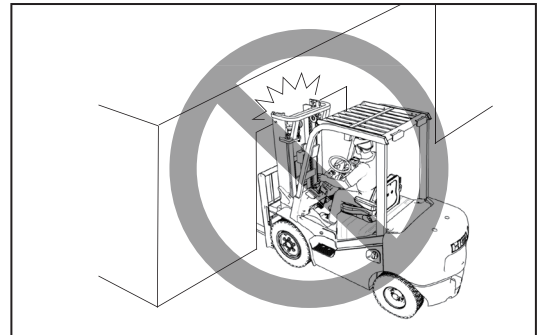

■ Do not travel on uneven or slipping road.

- Do not travel on uneven or soft road or serious accident will occur if steering is out of control or tire is sunk into mud;
- Avoid travel slipping road with water or oil, or you will lose control of braking and steering.

■ Pay attention to the load weight limit.

- Never overloaded when travelling on road with weight limit.

■ Do not travel over the barriers directly.

- Avoid sundries, road teeth, rail, open trench and other barriers and do not travel over them. The compact force will cause body harm such as backpain.

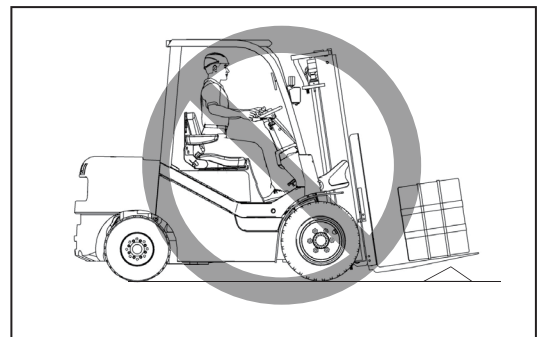

■ Avoid travel on road shoulder.

- Do not travel close to the road shoulder which may sink.
- Keep a safe distance from the road shoulder or platform in preventing of truck falling.

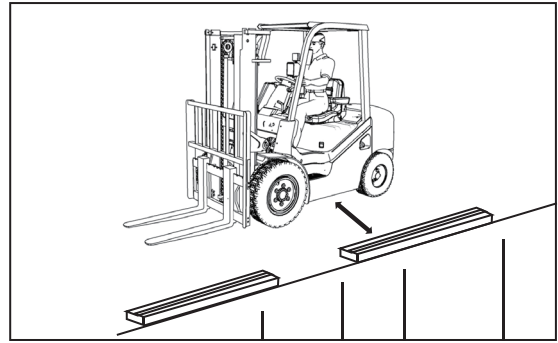

■ Notes when travelling on a slope

- Do not make a sharp turn on the slope and take care of the distance from other truck, and departure angle avoiding danger;
- Before travel on a slope, stop the truck and adjust the distance between the fork and ground to keep the bottom of fork and pallet away from the ground, so as to avoid the fork top inserting to ground.

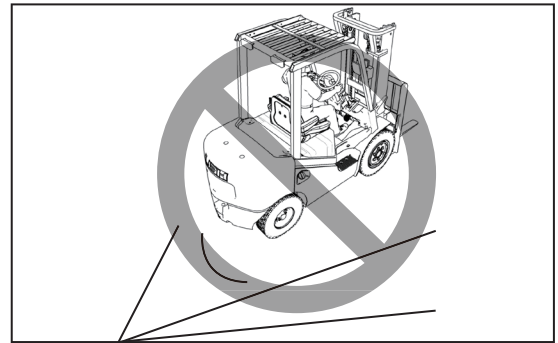

■ Safe travel on a slope

Loaded: travel forward when driving uphill; travel backward when driving downhill;

Unloaded: travel backward when driving uphill; travel forward when driving downhill;

- Travel downhill slowly with engine brake;
- It is prohibited to move your hip away from the seat when travel up or down the slope if the hydraulic-powered truck is assembled with OPS device or the power will be cut and accident will occur.

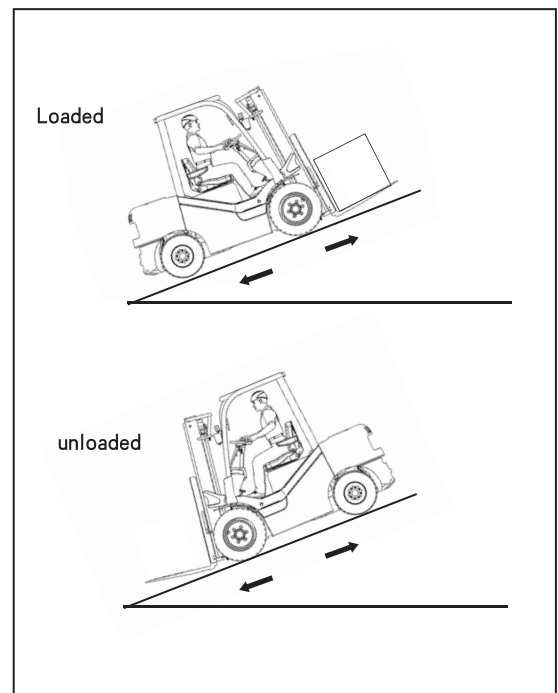

■ Notes when travel into railway lorry or container

- Check the brake and block applying to the lorry, trailer and container and make sure they are well stopped;

- Do not move the vehicles before the load carrying operation is finished;
- Make sure the board connecting to the vehicles can hold the travelling of forklift truck;
- Board should be connected firmly between lorry and trailer;
- Do not travel near the border of the platform or dock or the truck may fall down.

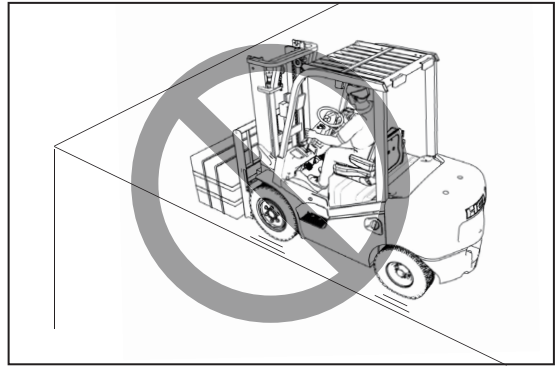

2.5.3 Notes on truck stopping and parking

■ Stop and park the truck according to proper procedures.

- Park the truck on solid and flat ground;
- Apply parking brake avoiding truck moving;
- Place the gear shifting levers on neutral.
- Tilt the mast and lower the fork to the ground;
- Turn the starting switch to the OFF position;
- Remove the starting switch key.

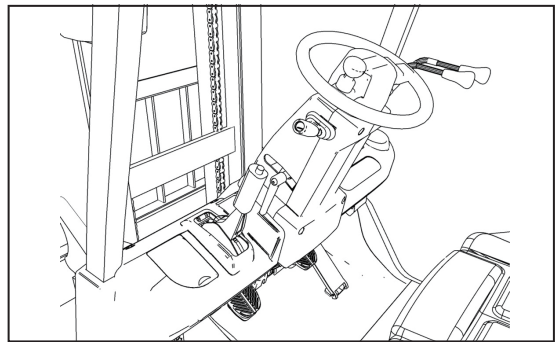

■ Park the truck at a safe place.

- Place the truck on solid and flat ground;
- Do not parking at the emergency exist or around safety devices; park at the place that does not disturb any passersby or other trucks;
- Do not park the truck on slope. If it has to, wedge the wheels.

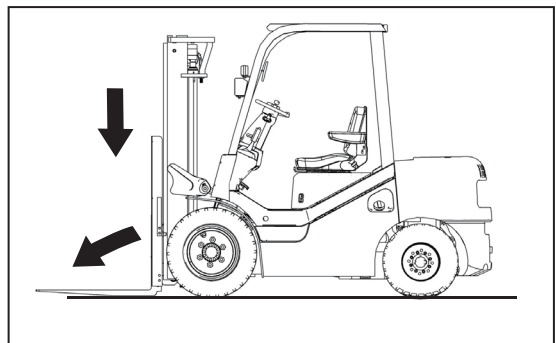

2.5.4 Notes on towing

- Proper using of traction pin
 - Traction pin is designed for the towing when it is sunk into channel or mud;
 - Do not use it for towing or lifting;
 - Use the traction pin as a fasten point when carrying by lorry.

- Do not tow damaged truck.
 - If there is any fault on the brake or steering system, do not tow with the other truck. Damaged truck may have accident during travelling.

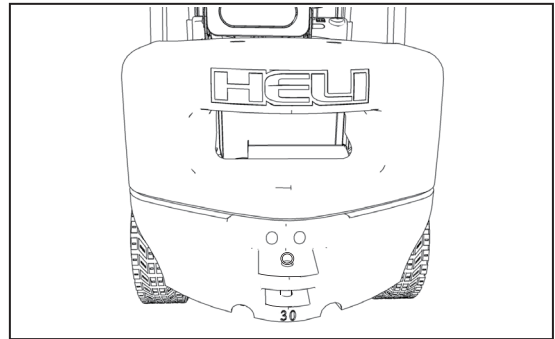

2.6 Load carrying operation

- When carrying loads, people and trucks without permit should leave the working area except for the towman.
 - Let the unauthorized persons and trucks be away from the working area except towman when loading and unloading to avoid accidents.
 - Assign a towman if necessary to ensure sight and other safety reasons;
 - Do according to the towman if towman works together.

- Do not stay under the lifted fork.
 - Lifted fork may fall down accidentally which may damage people under the fork. So stay away from the lifted fork.

- It is prohibited to work on fork.
 - Do not place load manually directly onto the fork;
 - Do not unload the load manually directly from the fork;
 - Do not step on the fork to load or unload goods because goods may slid from the fork;
 - Do not support the goods with hand because the sudden moving may cause load falling onto people.



- Take care not to be caught by mast.
- Do not put hand, feet or other parts of your body into mast;
- There is a danger of being caught by moving parts and serious injury.

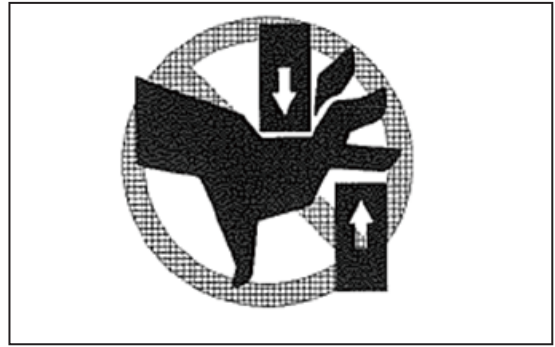

- Do not stand between the mast and driver's cab because serious injury or death may be caused by extruding.
- Operate the mast and fork from the driver's cab.



- Do not climb the mast or backrest.
- There is danger of being caught by moving parts or falling if you climb onto the mast or backrest.

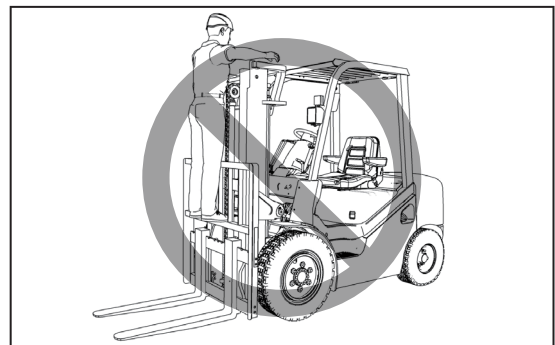

- Use the pallet with enough strength.
- Use pallets and sliding plates with strong structure. Do not use damaged one.
- Before travelling, check if the goods are placed on the pallet firmly and safety.

- Take care when carrying long and wide goods;
 - Take care when carrying long and wide goods. Lift the goods slowly so as not to collide anything around;
 - Keep the goods as low as possible and keep balance when changing direction.

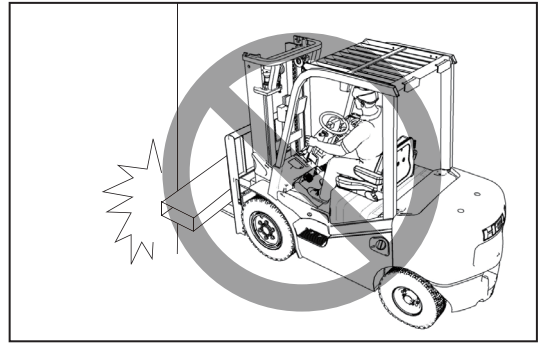

- Pay attention to the mast height
 - The mast height will increase with the lifting of fork. Take care when carry out such operation;
 - Take care not to touch electric wire, pipeline, water sprinkler, cross beam and so on. If there is any touch, goods on fork may fall.

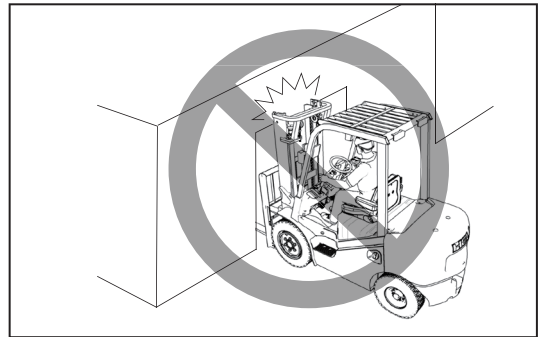

- No over loading.
 - The rear wheel will be away from the ground if the truck is over loaded and thus the truck will be out of balance. Do not exceed the max. capacity listed in the chart.

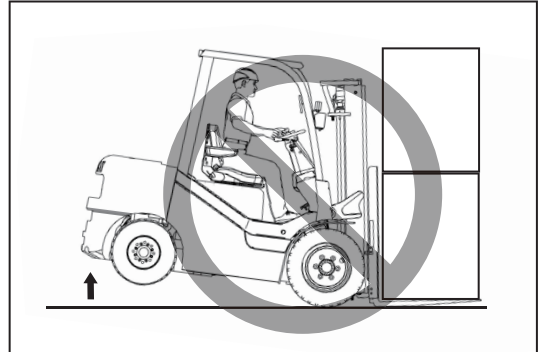

- Do not tilt the mast forward if there is load on the fork.
 - Do not tilt the mast forward when the load is lifted, or the good may fall down and truck may tip over;
 - Do not travel with the mast tilt forward.

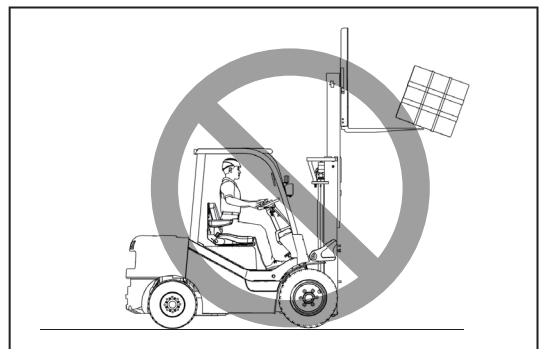

-
- Do not carry goods with insecurity measure.
 - Make sure the goods' center of gravity is in the same line with the truck's center of gravity. Do not carry unbalanced goods;
 - Fix the goods avoiding falling or collapse. Do not carry unstable goods;
 - Keep the goods in touch with the backrest.

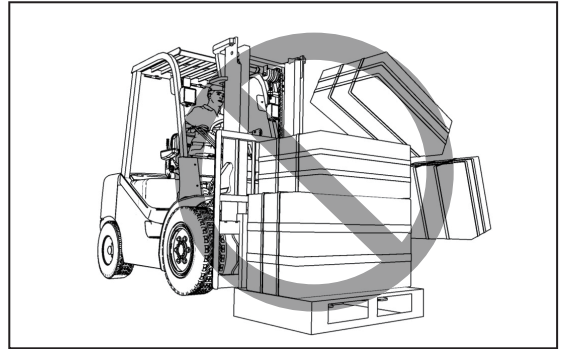

- Do not load and unload on a slope.
 - The truck will be out of balance and tip over when loading and unloading on the slope.

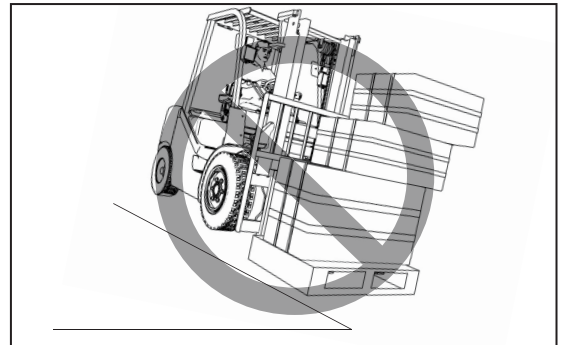

- Do not lower the loaded fork sharply.
 - Do not operate fork carelessly or stop it suddenly. Sudden lowering may cause goods to sink or fall down and thus the truck will be out of balance and tip over.

- Do not carry goods higher than the back rest.
 - If the goods are higher than the backrest, there is a danger of goods falling onto driver. So never carry goods higher than the back rest.

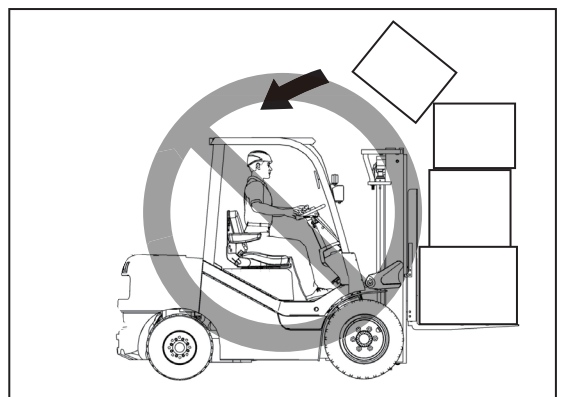

- Do not push goods by the tip of fork.
 - Do not push goods by the tip of fork or the good may break away from the fork tip and be damaged. The reaction may cause the truck and goods to move accidentally and is dangerous.

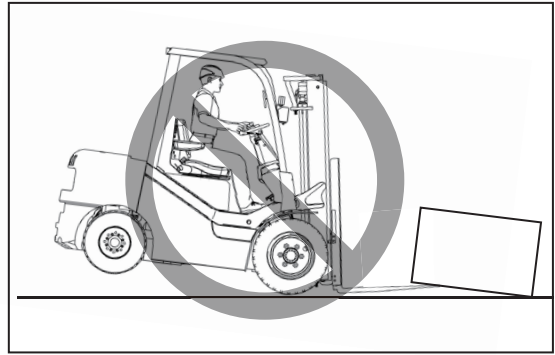

- Do not push or pull goods by fork.
 - There is a danger of goods damage or falling down.

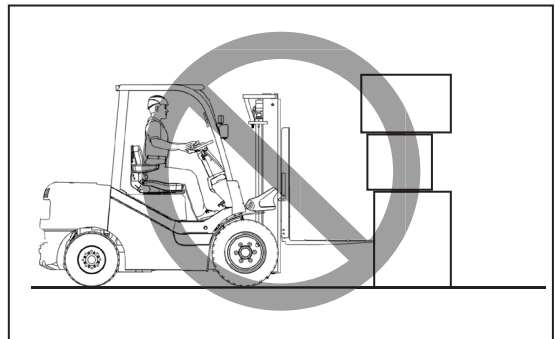

- Do not use the truck in other applications.
 - Do not use the truck in other applications except carrying goods with forks and other attachments;
 - Do not open or close the door of the wagon or warehouse;
 - Do not push or pull other vehicles;
 - Do not lift goods with rope. The rope hanged on the fork may slip, break away from the fork or be damaged. And meanwhile the truck may be out of balance because of the rotating of goods.

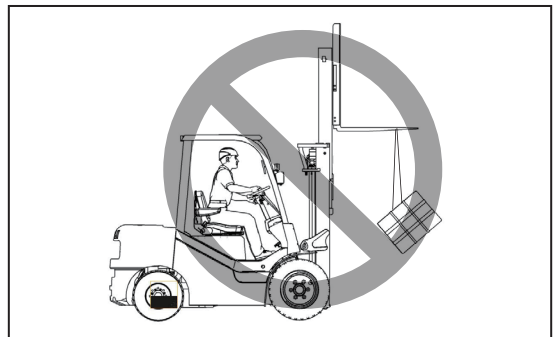

- Prohibition of fork tip working
 - Do not push a load or lift up by the tip of forks. When catch a load by the tip of forks, it can cause jumping up of the truck or a load and permanent deformation of forks.

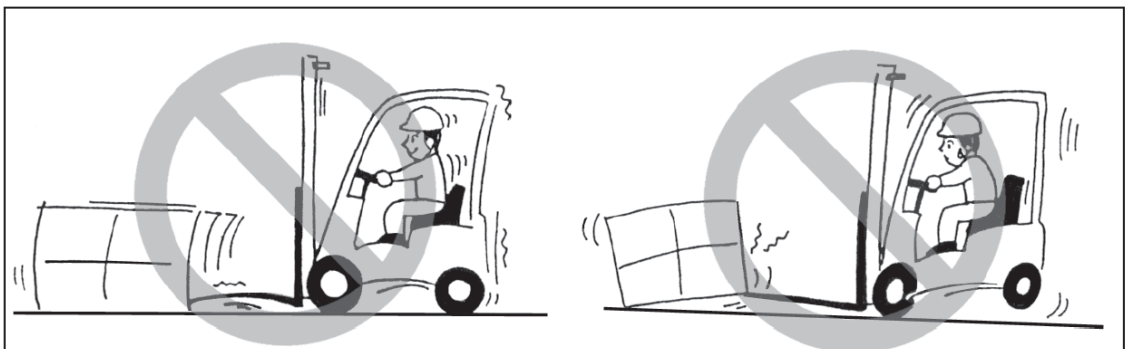

■ Prohibition of prod goods horizontally with forks

- Do not prod goods horizontally with forks or parts damage may be caused.

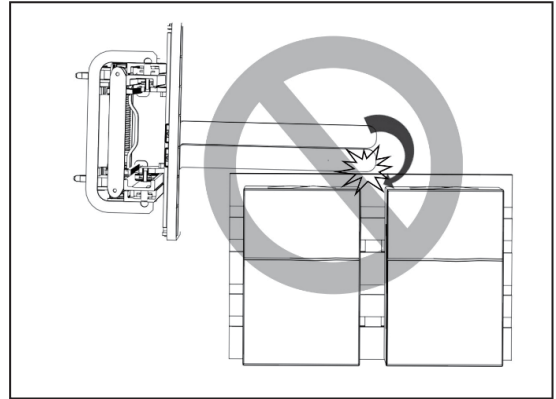

■ Prohibitions of carry goods with a single fork

- When loading, two forks shall be loaded at the same time. When using a single fork to pick up goods, the goods will fall off and the parts of will be damaged.

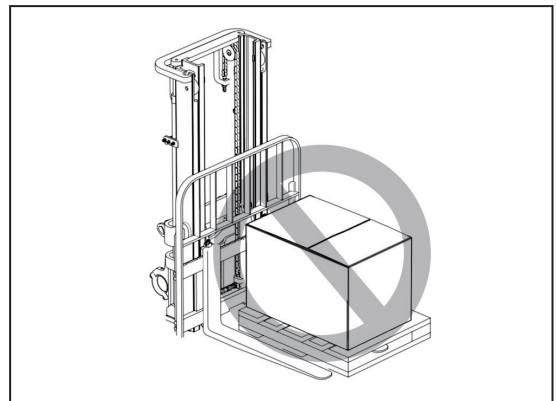

■ Prohibition of carrying goods with arc-shaped bottom

- When the forklift truck is loaded, the load shall be evenly distributed on the upper surface of the horizontal section of the two forks, and the direction of force should be vertical downward, so that no force of other direction can be generated; it is forbidden to carry the goods with arc-shaped bottom.

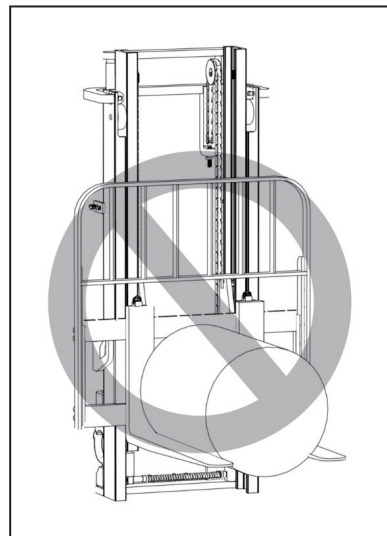
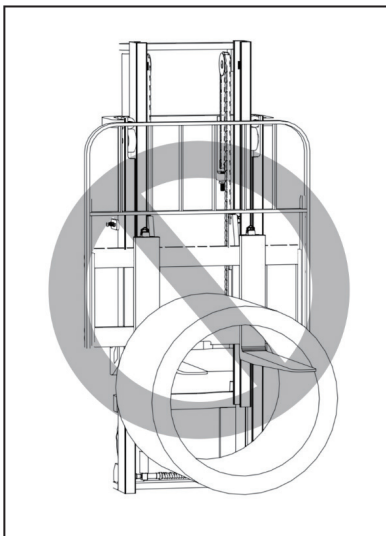

2.7 Check and maintenance notes

2.7.1 Be sure to carry out the starting check

■ Only easy check and maintenance are included in the OPERATION AND MAINTENANCE MANUAL. For the check and maintenance that should be carried out by trained and qualified people, please contact with HELI dealer/agent.

- Do not start the truck before starting check;
- If there is any abnormal, report to the manager at once and do not operate the truck until it is repaired;
- Serious accident and adverse effect may be caused by improper check, maintenance and repair. For safety reason, contact with HELI dealer/agent for certain check, maintenance and repair.

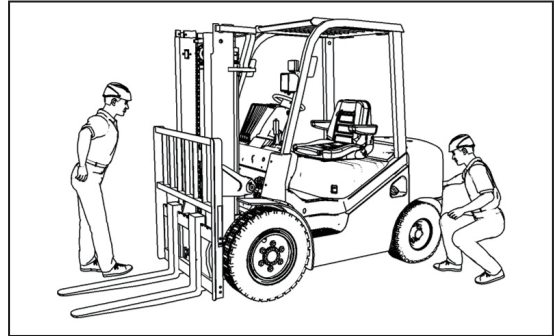

2.7.2 Place a warning sign around during check and maintenance

- Place a warning mark on the steering wheel or operation lever when checking and maintaining. If necessary, place the mark near the truck.
- During check and maintenance, Nobody is allowed to start engine or operate levers except the checking and maintenance person, or serious injury may be caused.
- Assign a responsible person and do according his guide when check or maintenance are carried by more than one person.

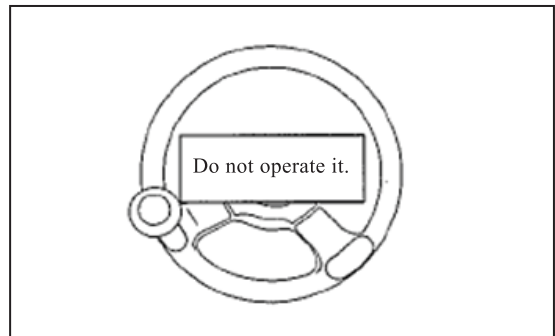

2.7.3 Keep the working area clean and tidy

- Keep the working area clean and tidy. Remove the barriers, grease and oil.
- The truck should work on flat ground with enough space.
- Ensure good ventilation if the truck works inside a building.

2.7.4 Notes before check and maintenance

- Allocate a fire extinguisher and know its position and using method;
- Keep the people with long or fluffy hair or loose clothes away from the mast during operation;
- Wear proper working suits and safety equipments (safety cap, safety shoes, glasses and gloves);
- Lower the fork to the ground and apply parking brake. Place all levers on neutral position and turn the starting key to OFF position and shut off engine;
- Wedge up wheels.

2.7.5 Let the unauthorized people be away

- Unauthorized people should not stay near the truck during maintenance.

2.7.6 Proper using of the tools and devices

- Use the proper tool correctly. Do not use damaged or deformed tool and tool using for other purpose or serious accident will be caused.



2.7.7 Notes when working under the working devices

- Support fork and mast avoiding falling when working under the fork or serious accident will be caused.

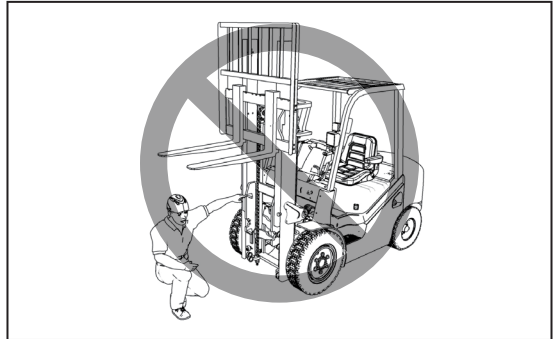

2.7.8 Beware not to be caught by mast or falling

- Do not put your hand, foot or other part into mast or there is a danger of being caught.
- Do not stand between the mast and driver's cab or you may be extruded and serious injury or death may be caused.



- Operate the mast and fork from the driver's cab.
- Do not climb onto the mast, backrest or splash guard, or you may slip into or be caught by moving parts. Check and maintain the top area with ladder.

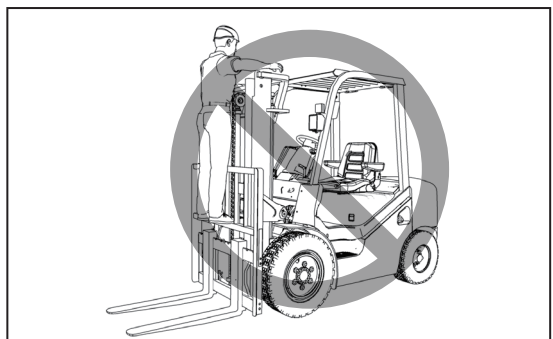

2.7.9 Beware of the boiling cooling liquid

- Do not remove the radiator's cap as soon as the truck is stopped because the cooling liquid has high temperature and pressure, or you may be scalded.
- When removing the radiator's cap, rotate it slowly until the cooling liquid is cool to release inside pressure.



2.7.10 Take care of the high pressure oil

Remember: the hydraulic system is under the pressure condition all the time. Before check or change hoses or pipes, check if the hydraulic system has pressure or serious accident may occur. Please abide the following description:

- Do not touch the hoses or pipes with hand directly when checking if there is leakage. The hoses and pipes may be pressurized.



- If your skin or eye is harmed by high pressure oil, wash with clean water at once and go to see a doctor.

2.7.11 Beware of the rotating belt and fan

- Keep your hand away from the rotating belt and fan.

- Shut off the engine before open the engine hood which is only can be done by authorized person.



2.7.12 Notes when repairing electric system

- Disconnect the cable of the positive terminal in order to disconnect the power when repairing electric system.

2.7.13 Notes when cleaning with compressed air

- Dust is harmful to health when washing with compressed air.
- Wear protection devices such as glasses, gloves and mask.

2.7.14 Notes when dealing with battery

The battery will produce hydrogen and oxygen during charging which may explode and electrolyte contains dilute sulphuric acid. Personal injury, explosion or fire may be caused if the battery is improper dealt. Please follow the rules below:

- Do not use the battery or charge the battery if the electrolyte is lower than the min. level. Or explosion may be caused.
- Wear safety glasses and rubber glove when dealing with the battery.
- Do not smoke or make the open flame be close the battery.

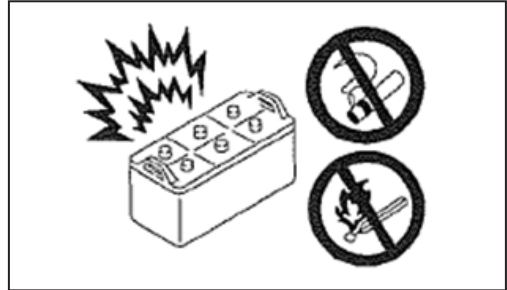

- Wash with plenty of tap water at once if any part of your body contact with the electrolyte.

- If electrolyte gets into eye, wash with plenty of tap water at once and see a doctor in time.
- Turn the starting switch to the OFF position when dealing with the battery.

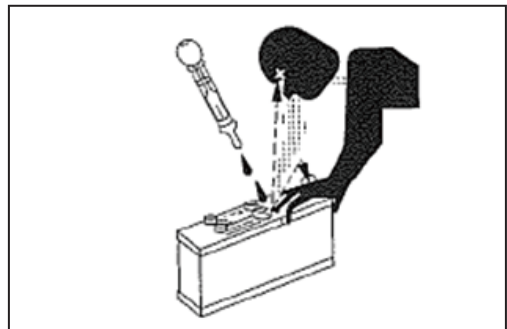

2.7.15 Follow the rules strictly so as to avoid spark

- Do not place tools or other metal object on battery for they may contact with the battery positive and negative terminals.
- Disconnect the negative terminal cable first when disconnecting the batter cable. On the opposite side, connect the positive terminal cable first when connecting.

2.7.16 Note when installing or removing the battery

- When installing or removing the battery, take care not to damage the battery or electrolyte may leak.
-

2.7.17 Note when dealing with the tyres

Deal with the tyre which has high pressure properly or the tyre may explode or be damaged and rim may be broken. For your safety, follow the notes below:

- Do not assemble or disassemble the tyre and do not inflate the removed tyre.
- For your safety, when changing or inflating the tyre, stay right before the tyre surface as shown in the figure. Never stay on the side of the tyre surface.

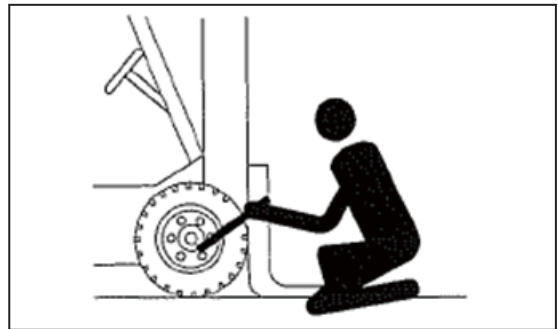

- When disassemble the tyre with separate rim from the truck, loose the nut (1) after pressure releasing. Do not loose the rim nut (2) with irregular shape. Please refer to 4.4.4 TYRE CHANGING for tyre changing.

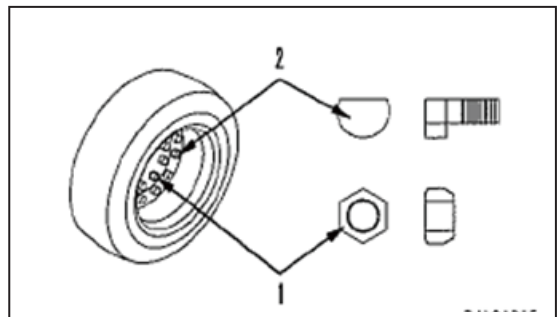

- Please use the special tyre for HELI truck and follow the set inflation pressure.
- Make sure there is no person around when inflating the tyre. Make sure the gas outlet port of the air pump is connected with tyre valve core tightly. Check with pressure gauge as inflate the tyre in order to avoid over inflation.
- Rim will not well fit the tyre if its improper assembled or there is any fault with the tyre or rim. Rim should well contact with the tyre in any place. If necessary, contact with HELI dealer.

2.7.18 Note when dealing with the waste

Take care to deal with the waste in order to protect the environment.

- Keep the waste liquor such as engine oil and electrolyte in a container like jar. (Do not keep the electrolyte in a metal container and be sure to keep it in a plastic container). Never drain the waste liquor into earth, river, drainage ditch, sea or lake.
- When dealing with injurant such as engine oil, fuel, cooling liquid, solution and battery, stick to the relative law.



2.7.19 Notes after check and repair

- Wipe off the oil and lubricating grease at once. If the truck is dirty, fault such as crack is hard to be found.
- Check if there is any abnormal after the truck is repaired.

2.7.20 Regular check on the key part

- Lubricate, check and maintain the truck especially the key parts regularly in order to ensure the truck safety and long service life. Change then regularly.
 - Parts will go bad, worn or fatigued if they overrun their service time and serious injury and damage will be caused. Parts service life is hard to be distinguished by visual check.
 - Replace the key parts regularly.
 - If there is any abnormal, change the key part even it is undue.
-
- Note
 - Check and change of the key parts and lubrication grease adding should be carried out by HELI dealer or agent.

2.8 Transportation and hanging up

2.8.1 Notes when hanging up truck

- Do not hang up the truck at the overhead guard.

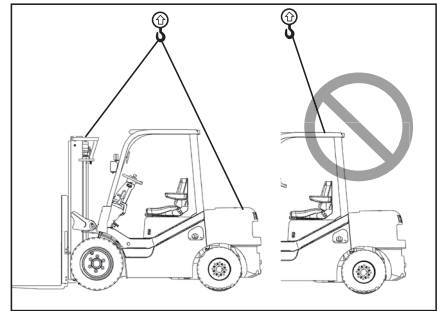

- Before hanging up, check if the bolts of the mast and counter weight are tightened to the regulated torque.
 - Refer to the “maintenance data” for torque value of the counter weight fixing bolts.
 - Refer to the “maintenance data” for torque value of the lower mast fixing bolts.
- When hanging up truck, hook the hole on the bottom of the external mast and the counter weight and rear axial.
- Do not stay under the lifted truck.
- Use undamaged slings and steel rope with enough strength.
- Please contact with HELI dealer or agent for special sling equipment if the truck has to be hung up frequently.

2.8.2 Notes when loading or unloading the truck

There is a danger of tipping over and falling when loading or unloading the forklift truck onto or from the trailer. So follow the rules below:

- Park the trailer on a flat road. Apply parking brake and wedge the wheels.
- Use connection board with proper length, width and strength.

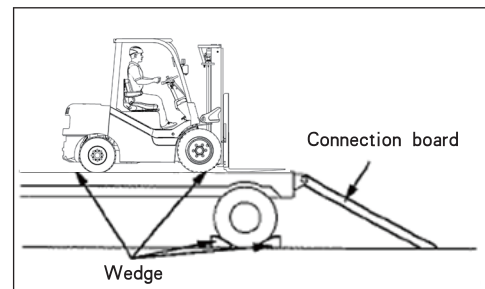

- Operate the truck with proper posture.
- If the truck which is hydraulic powered type and is assembled with OPS is operated with such posture (the seat does not bear your whole weight, for example stand or lean against forward, backward or side when operating), the power will be cut for 3 seconds and in that case, the truck will slide down even acceleration pedal is pressed or the truck is going uphill. If necessary, assign a towerman, so that the driver is not necessary to stand or lean forward or side to observe around.
- Place the board to form a gentle slope when using it. Align the center of the forklift truck and trailer's and lock firmly avoiding displacement.
- Do not change the direction when travelling on a board. If necessary, place the board again according to the needed direction and travel again.

2.9 Truck structure and stability

2.9.1 Longitudinal stability

- Load is balanced with the weight on the rear wheel with the front wheel as the supporting point so as to avoid truck tilting forward.
- If the truck is overloaded, the rear wheel will lift away from the surface. It is dangerous and serious accident will occur such as tipping over.

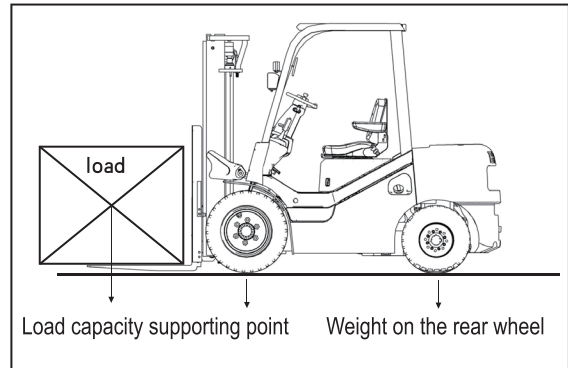

2.9.2 Load center of gravity

- Shapes of goods are different.
- Ensure load center of gravity is very important for truck stability.

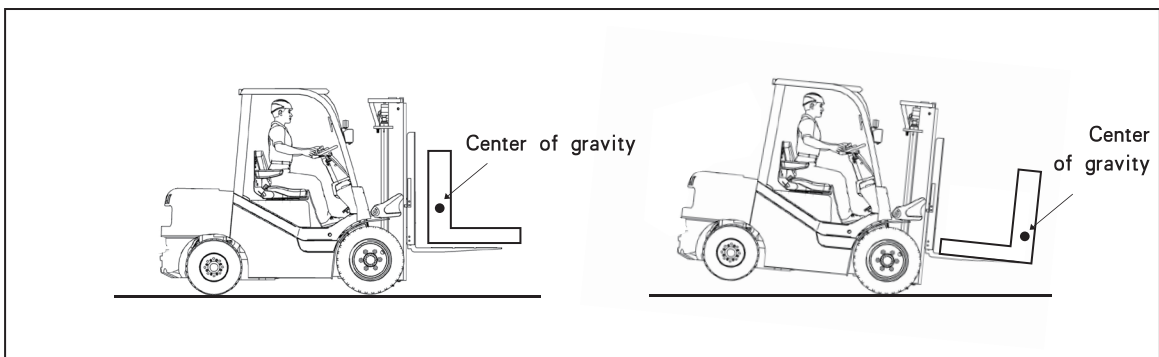

2.9.3 Combined center of gravity and loaded truck stability

Combined center of gravity

The loaded truck's center of gravity is moved to the combined center of gravity of the truck and goods. The combined center of gravity is lifted as the goods are lifted.

Combined center of gravity and stability

The stability in both longitudinal and horizontal direction will be poorer and poorer with the center of gravity being higher and higher. Besides, swinging and vibration during travelling and loading affect the truck stability.

■ Truck stability will change because of the following factors:

- Load size, weight and shape (center of gravity)
- Lifting height
- Mast tilting angle
- Tyre inflation pressure
- Acceleration and deceleration during travelling and lading and unloading and steering speed
- Road condition and gradient
- Attachments type

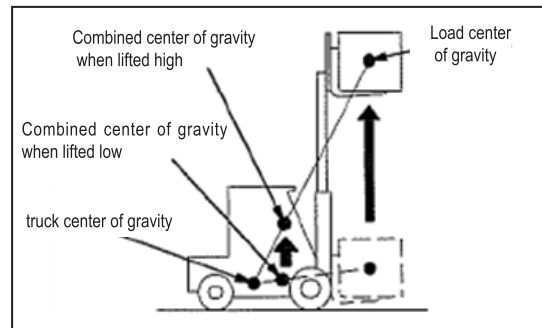

Do not travel when the fork (goods) is lifting; do not steer sharply; do not brake suddenly; do not lift or tilt fork suddenly; or there is a danger of accident such as tipping over.

2.9.4 Actual loading capacity

■ Load center refers to the horizontal distance from the center of gravity on the fork to the backrest. Actual loading capacity is the max. loading capacity on certain load center.

■ Capacity chart on the name plate can be seen from the driver's seat. It shows the relationship between the actual loading capacity and the load center.

■ When load center moves to the fork tips, lower the load capacity to maintain the balance in actual operation.

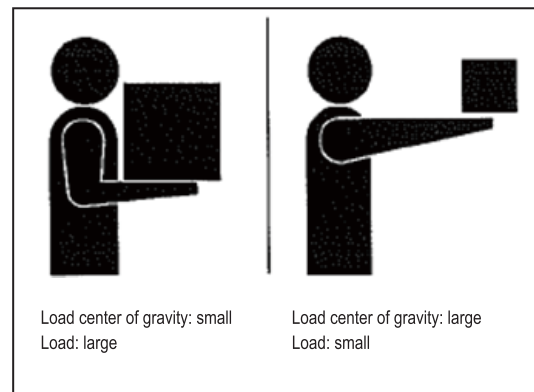

2.9.5 Instruction on the capacity chart

■ Instruction on the capacity chart

- The actual loading capacity and max. load capacity are shown in the capacity chart. Before loading, make sure the load center and load capacity are in the allowed range.
- Fix the load if it has complex shape in order to make the heaviest part lay against backrest and the horizontal center stay on the center of the two forks.
- The rear wheel will be away from the ground if the truck is over loaded and thus the truck will be out of balance. Ensure the load capacity stays in the allowed range.
- Series number plate on the truck shows the work in permit range. Contact with HELI dealer or agent to change the damaged or unclear plate.

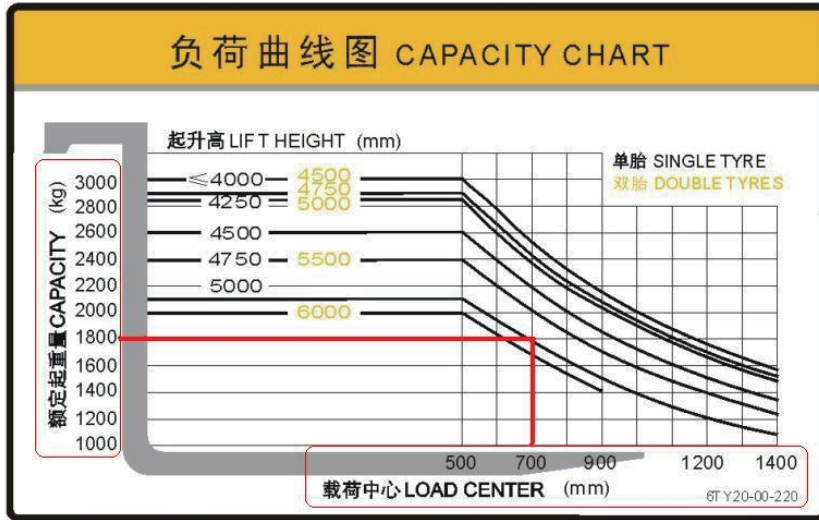

If the load capacity exceeds the requirements in the capacity chart, the truck's rear wheel may be lifted away from the ground. In that case, steering may be out of control and the truck may tip over. If the truck is assembled with attachments such as side shifter, clamp, rotator and so on, the allowed capacity will be lowered than the capacity of the truck without attachments. The reasons are below:

- a) The capacity is attachment weight lower than the one of the truck without attachment.
 - b) Long attachments make the center of gravity forward and thus the loading capacity will be reduced.
- According to the truck and attachment brochures, calculate the actual capacity through the loading capacity formula if attachment is assembled by yourself or contact with our company.

2.9.6 Instruction on safety devices choice

Safety devices are optional. Contact with HELI dealer or agent for detail. Devices and equipments listed below may not work in certain conditions. Install the devices according to the instructions for safety reason.

- Working light
 - on top of the truck and at the rear side of the truck
- Travelling (forward/backward) or approaching alarm
 - rotating warning light and flash light
- Speed alarm
 - Speedometer and buzzer
- Fire extinguisher

2.10 Towing

■ Fault truck towing

Be care if there is any of the fault below when towing a truck:

- Fault of brake
- fault of steering
- fault of tyre
- fault of traction pin
- Move the truck on a abrupt slope

The truck is hard to control if the steering motor does not work. if there is no power, there is no powered steering. Do not tow the truck which has no power, or truck may be damaged or slip because of improper towing.

If towing on a abrupt slope, apply another brake power to stop the truck.

Never handle the fault truck with another forklift truck unless it has to be moved and it can not be towed. The handling truck must has the capacity equals to or larger than the weight of the fault truck. The towing truck's fork length must larger than the width of the whole fault truck. Keep the weight of the fault truck stay on the center of two forks. Take care not to damage the bottom of the truck.

■ Towing

Towing method:

- The towed truck must have operator.
 - Tow the truck slowly.
 - Lift the pallet and mast for towing.
 - If a forklift truck is used to tow a fault truck, the truck's capacity must be no less than the fault one.
- When towing, load the truck with goods that have half of the rated capacity's weight to increase the towing force and keep the goods as low as possible.
- Connect the two truck's towing pin on counter weight with a steel traction chain.

OPERATION



WARNING

Please read the manual and safety notes carefully.

When operating the truck, please follow the safety notes or serious injuries may be caused.

3.1 General view

3.1.1 Truck general view

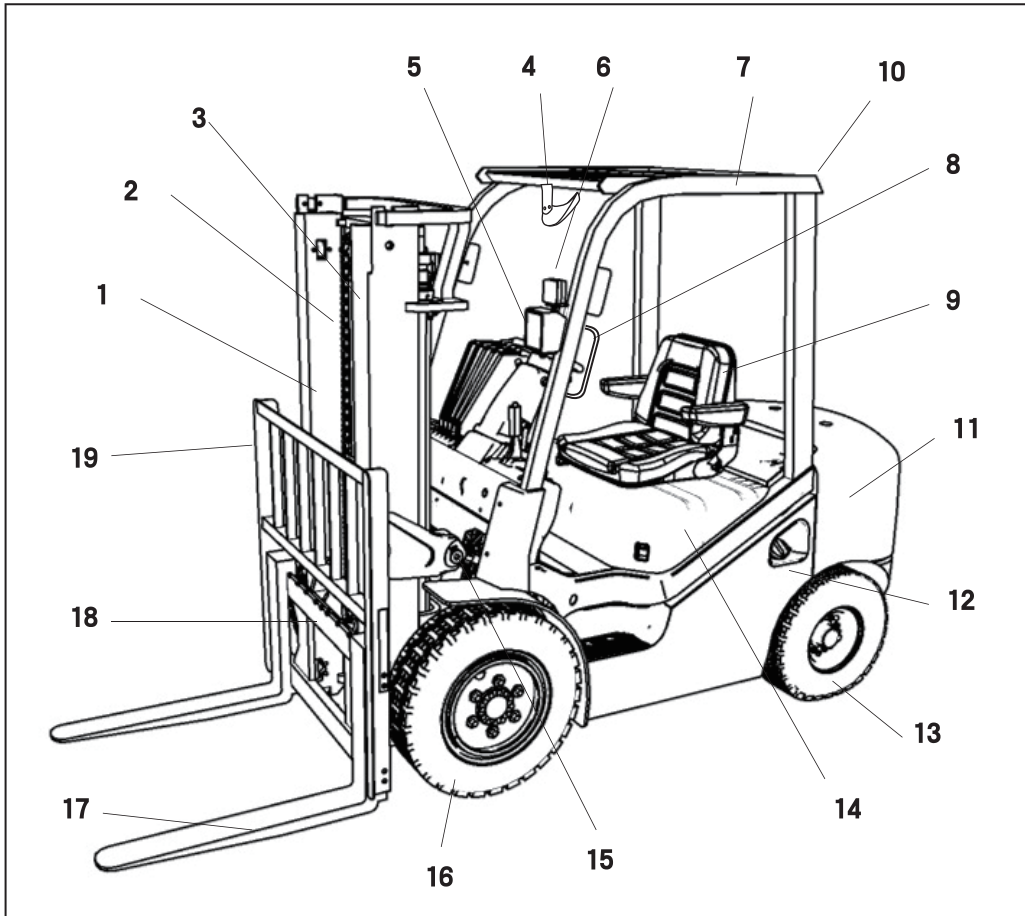

- | | |
|---|----------------------|
| 1. mast | 11. counter weight |
| 2. Lifting chain | 12. Fuel adding port |
| 3. Lifting cylinder | 13. Rear wheel |
| 4. Rear view mirror | 14. Engine hood |
| 5. Front lamp | 15. tilt cylinder |
| 6. Steering light and stopping light | 16. Front wheel |
| 7. Overhead guard | 17. Fork |
| 8. handle | 18. Fork bracket |
| 9. Seat | 19. Backrest |
| 10. Rear combined light (steering light, backward light, braking light , width light) | |

3.1.2 Instrument and control devices

■ Cab

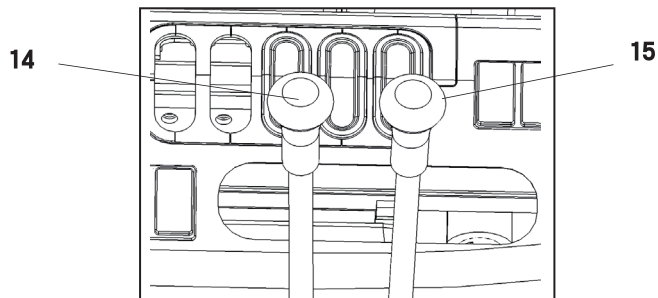
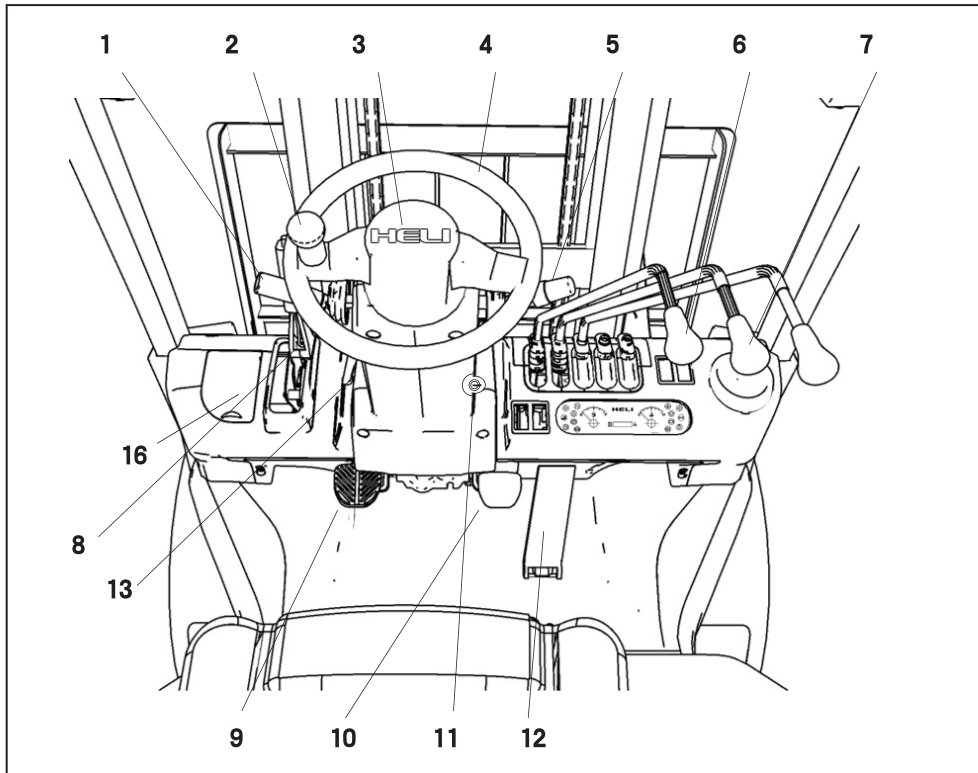

- | | |
|---|--|
| 1. forward/backward operation lever (hydraulic-powered truck) | 9. Clutch pedal (mechanical type truck) |
| 2. Steering wheel ball type handle | 10. Brake pedal |
| 3. Horn | 11. Starting motor switch |
| 4. Steering hand wheel | 12. Acceleration pedal |
| 5. Combined light switch | 13. Tilttable steering hand wheel lock lever |
| 6. Lifting lever | 14. Forward/backward operation lever (mechanical type truck) |
| 7. Tilting lever | 15. high speed/low speed operation lever (mechanical type truck) |
| 8. Parking brake | 16. Brake liquid reservoir |

3.2 Parts instruction

■ Devices necessary for the truck are described below.

It is very important to be familiar with the devices in order to operate the truck properly.

3.2.1 Meter

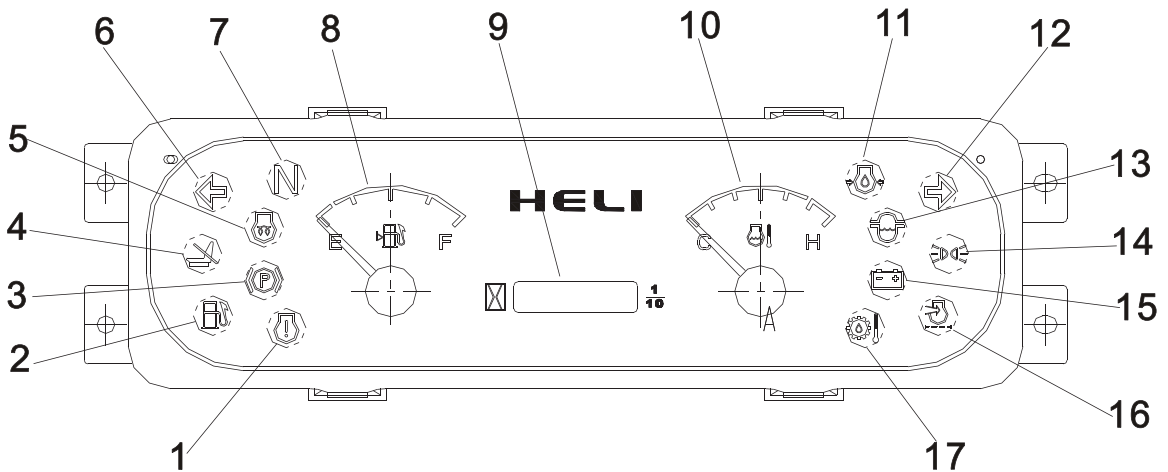

1. engine fault signal (optional)
2. Low fuel alarm
3. Parking brake signal (hydraulic-powered truck)
4. OPS indicator
5. Preheating indicator (truck with diesel engine)
6. Left turning indicator
7. Neutral indicator
8. Fuel gauge

9. Hour meter
10. Engine coolant temperature meter
11. Engine oil pressure alarm indicator
12. Right turning indicator
13. Oil-water separator alarm indicator (truck with diesel engine)
14. light switch indicator
15. No charging alarm indicator
16. Air cleaner block alarm indicator (optional)
17. Torque converter oil temperature alarm indicator (optional for hydraulic-powered truck)

■ Methods of alarm indicators' bulbs checking

- Make sure the alarm indicators light on when the engine is not working and the starting switch is turned to ON position.
- Check if the bulbs are damaged if any of the indicator is off. It is abnormal when the alarming indicator is on during operation. Repair it and contact with HELI dealer or agent.

■ Fuel gauge

Oil quantity is shown on the fuel gauge. Check it on a flat ground. Check the oil quantity when the engine starting switch is on ON position.

Position E: it means that the oil level is low.

Position F: it means the oil tank is full.

Add fuel before it runs out.

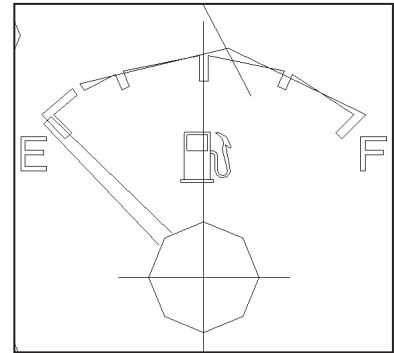

■ Neutral indicator

Neutral indicator means the forward/backward operation lever is on neutral position.

When the starting switch is on ON position, the neutral indicator will light on if the forward and backward operation lever is on neutral position. The indicator turns off when the lever is on forward or backward position.

Before starting the engine, turn the starting switch to the ON position and check if the neutral indicator is on.

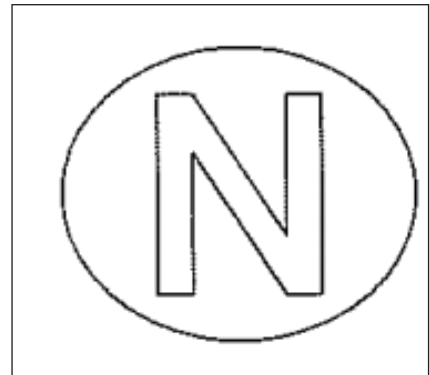

■ OPS indicator (hydraulic powered truck) (optional)

When OPS is activated, the indicator turns on and the transmission box power is cut.

When you sit on the driver's seat with proper posture and place the forward/backward operation lever, the indicator turns off and the truck is ready for travelling.

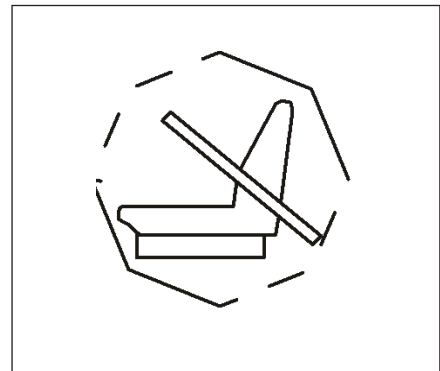

■ Engine oil pressure alarm indicator

It means the abnormal of the engine lubricating oil pressure.

The light will turn on when the starting switch is turned to ON position and it will turn off after the engine is started.

During operation, stop the engine and check the engine lubricating system and engine oil level when it turns on.

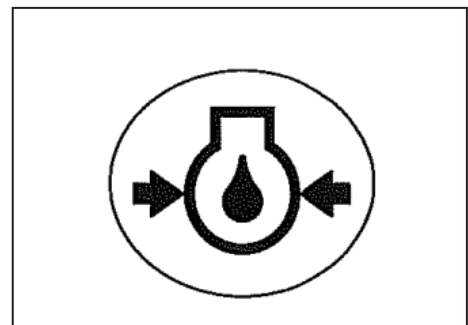

■ No charging alarm indicator

When the engine is working, the alarm indicator means the abnormal of the AC type generator's charging system.

When the starting switch is turned to ON position, the indicator will turn on and it will turn off after the engine is started.

During travelling, if the indicator turns on, check the electric system and if the V belt is loose.

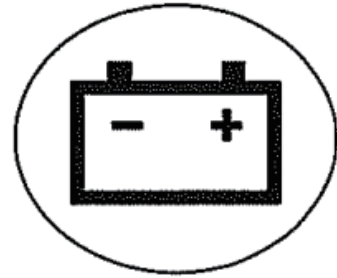

■ Working indicator

The hourglass signal on the left side of the hour meter means the hour meter is working.

The signal flickers when the engine is working.

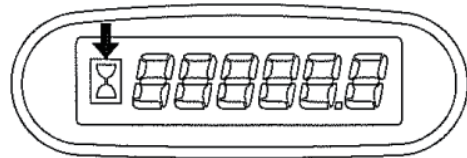

■ Hour meter

When the engine is started, the hour meter begins to work and accumulated working time is displayed. (when the hour meter is working, the operation indicator keeps flickering.

Affirm the checking interval and working hours referring to the hour meter.

If the engine works 6 minutes continually, 1 is carried over to the last digit (it means 0.1 hour.)

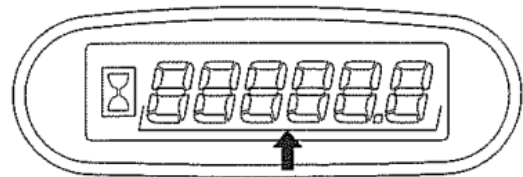

■ Oil-water separator alarm indicator (it is used as fault indicator.)(truck with diesel engine)

When the water in the oil-water separator reaches to certain quantity, the indicator will turn on and the water in it has to be drained. If not drained, the performance of fuel injection pump and nozzle will be badly affected. Refer 4.4.3 water and gas exhausting of the water-oil separator for detailed operation (truck with diesel engine).

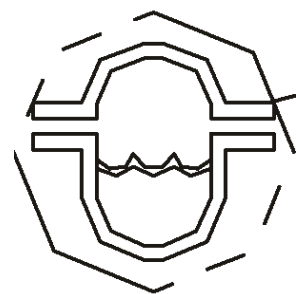

Important

If the indicator lights on, stop working and report the fault to the manager or contact with HELI dealer or agent for check.

■ Preheating indicator (truck with diesel engine)

The indicator means that the engine is preheating.
When the starting switch is turned to ON position, the indicator turns on and will turn off 14s later.



■ Engine coolant temperature meter

Engine coolant temperature is indicated by a pointer.
White range: normal
Red range: over heat

Important

Stop operating the truck at once and park it in a safe place if the pointer point to the red range and then carry out corresponding measures.

For engine overheating, refer to 4.7 Measures of engine overheating.

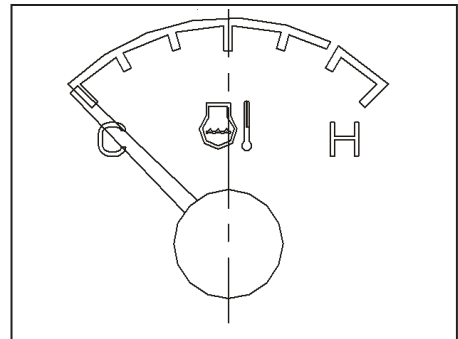

3.2.2 Operating devices

■ Starting motor switch

The switch is used to start or shut off the engine.

(1) [0] position: on OFF position, you can insert or draw out the starting key.

(2) [I] position: on ON position, the electric circuit has electricity. For truck with diesel engine, preheating is started automatically.

(3) [II] position: On starting position, starter begins to work so as to start the engine. The key will be back to [I] position automatically when you loose the engine starting key after the engine is started.

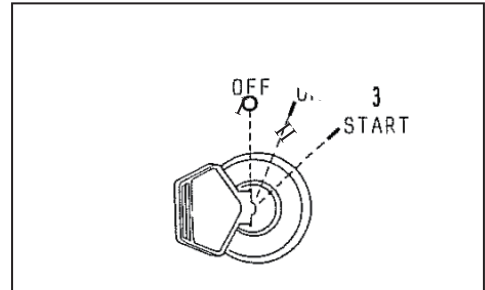

Important

Do not let the starting key stay on the [I](ON) position or battery electricity will be reduced and is hard to start the engine.

■ Horn

Press the button on the middle of the steering hand wheel and the horn will sound.

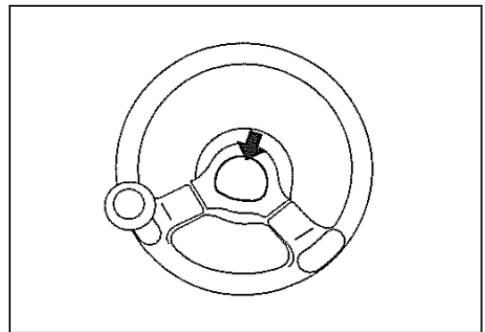

■ Forward / backward operating lever (hydraulic-powered truck)

The lever is used to change the truck travelling direction (forward/backward).

↑ : F(forward)

● : N(neutral)

↓ : R (reverse)

Engine will not be started if the lever is not on N (neutral) position.

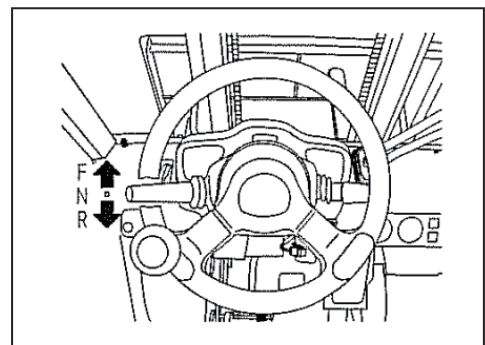

■ Forward/backward operation lever, high speed/low speed operation lever (mechanical truck)

Forward/backward operating lever (1) is used to change truck travelling direction. high speed/low speed operation lever is used to change truck speed. Engine will not be started if the lever is not on N (neutral) position.

Forward/backward operation lever (1)

- ↑ : F (forward)
- : N (neutral)
- ↓ : R (reverse)

High speed/low speed operation lever (2)

- 2: High speed
- : N (neutral position)
- 1: low speed

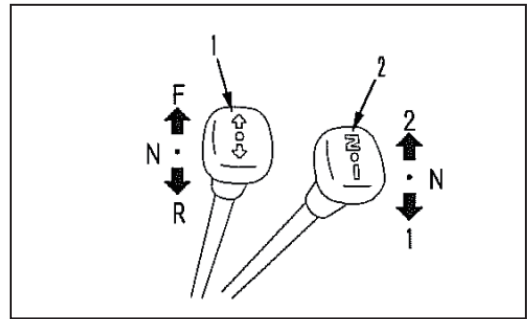

NOTE: If you have operation lever with different arrangement or control direction, check the remark on top of the lever before operation.

■ Combined light (lighting/steering signal switch)

The knob is fixed with lighting and steering signal switch.

■ Lighting switch

When the switch is turned to the arrow mark, lights will turn on or off as shown below.

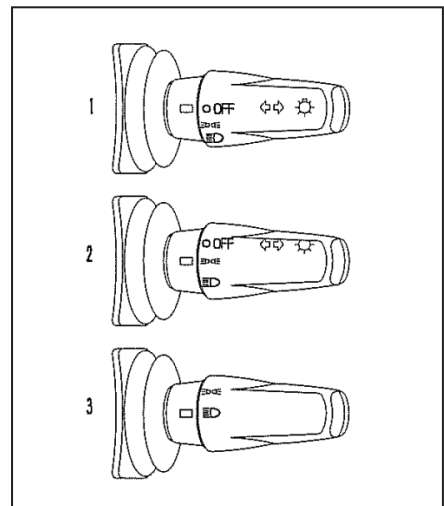

NO.	Front light	Meter light, side marker, front width light, rear width light and tail light
1	OFF	OFF
2	OFF	ON
3	ON	ON

■ Steering signal switch

Left turning (L): push the knob forward

Right turning (R): pull the knob backward

When turn the steering hand wheel backward, the knob will go back to neutral position.

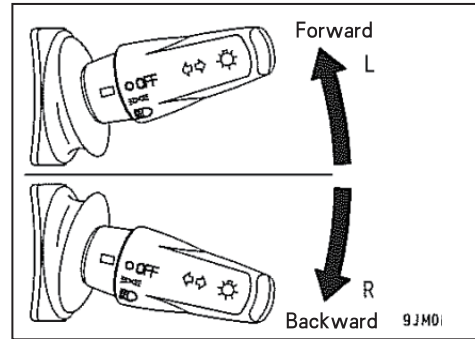

■ Parking brake handle

The handle is used to operate parking brake.

Pull the handle back completely (to lock position) and the parking brake is applied.

When releasing parking brake, pull the handle back and press down the button on top of the handle at the same time. Then press the button and push the handle forward at the same time to make the handle to be placed at the very leading position.

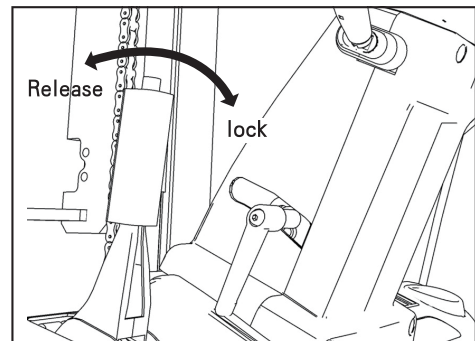

■ Acceleration pedal

The pedal is used to adjust travelling speed.

Engine rotation speed will increase according to the stepping distance.

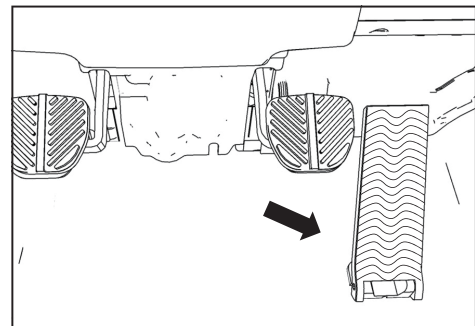

■ Brake pedal

The pedal is used to stop or slow down.

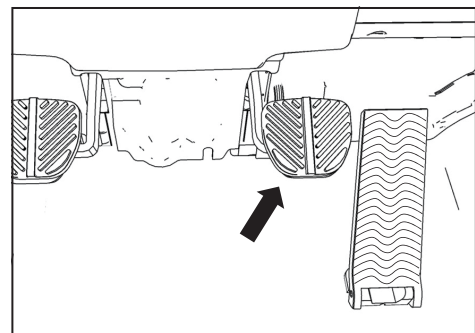

■ Clutch pedal (mechanical truck)

When operating forward/backward lever or high speed/low speed lever, the pedal will be used. Before operating forward/backward lever or high speed/low speed lever, step on the pedal fully and release it slowly after operation.

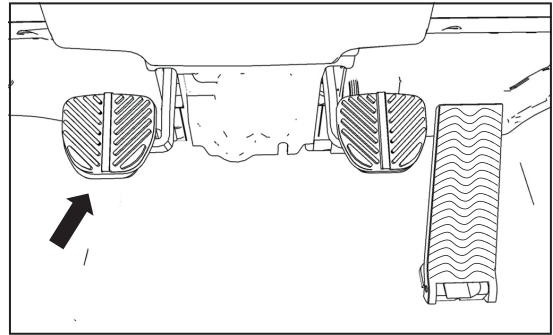

■ Inching pedal (hydraulic-powered truck)

When travelling with low speed (such as loads handing operation), the pedal is used to adjust the travelling speed.

Step on the pedal slightly to make the clutch half engaged and the truck will inching forward. Step the pedal more and the brake pedal together, the brake force is applied. Step on the pedal fully and the clutch will be separated and brake force will be applied.

■ Lifting control lever

It is used to control the fork lifting and lowering.

Lifting: press the control lever downward;

Lowering: push the control valve upward.

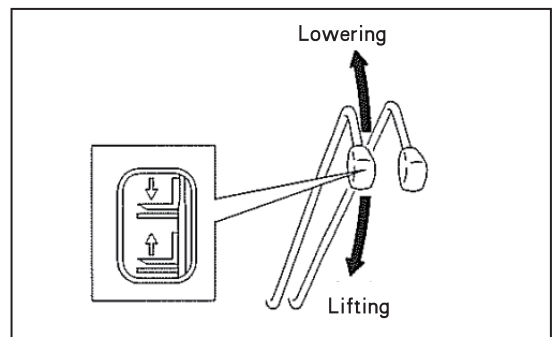

■ Tilting control lever

It is used to tilt the mast forward or backward.

Tilt forward: Push the control valve upward;

Tilt backward: Press the control lever downward

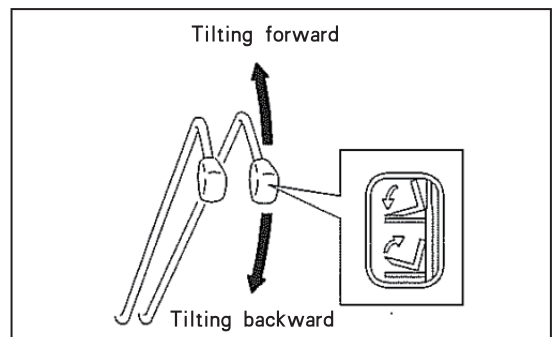

■ Steering hand wheel and knob

Steering hand wheel is used to change the left-right direction. Operate the steering hand wheel with the knob.

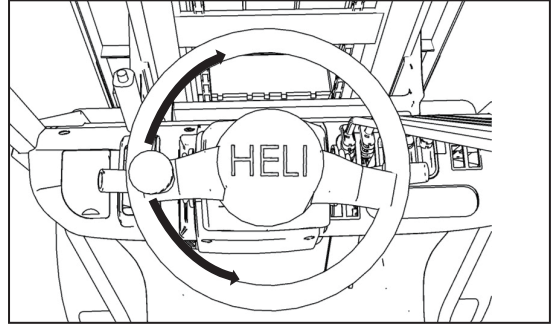

■ Tiltable steering hand wheel lock lever

The lever is used to adjust the steering hand wheel tilting angle (upward/downward). Raise the lever, the steering hand wheel lock nut will lose and the steering hand wheel tilting angle can be adjusted. Push the lever down to lock the steering hand wheel after adjusting.

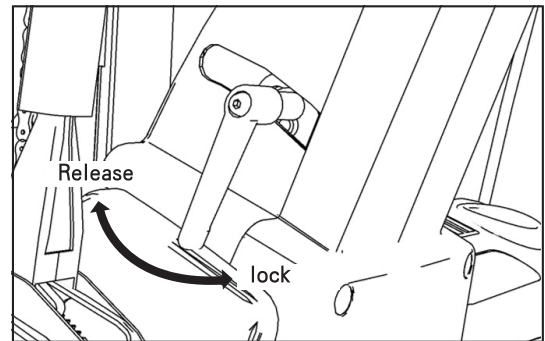

3.2.3 Assembly and disassembly of the attachments

Safety notes

 **WARNING**

Attachments and main parts are heavy and serious injury will be caused if they are carried improperly.

1. When working under the lifted attachments with goods, fix them avoiding lowering. Do not walk or stay under the impending goods. Use load support equipments such as steel rope and steel chain with good condition.
2. If work is done, fix the truck avoiding truck moving accidently.
3. When repairing or changing the hydraulic or electrical parts, observe truck related set value.
4. Any person is prohibited to stay in the dangerous place around the truck.

■ Fork

- Lower the fork bracket and until the fork contact with the ground and the lifting chain is under the tight condition.
- Lose the fork stopper and move the fork to the middle position. Put the lower hook to the cut and disassemble the fork.
- The steps of assembly are opposite from the disassembly. Apply grease to the fork hook and adjust the fork to proper width.
- Forks with pairing marks shall be installed in a paired way. It is strictly forbidden to install in a mixed way.

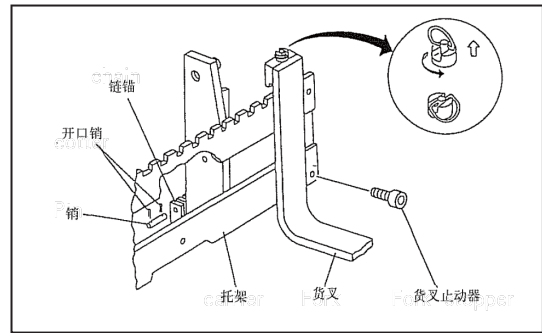

■ Fork bracket

- Lower the fork bracket until the fork contact with the ground.
- Disconnect the lifting chain and connect the end of the chain to the upper beam of the outer mast.
- Lift the inner mast with the lifting equipment until the bottom of the inner mast be away from the roller assembly on top of the carrier.
- Make sure that the chain does not kink when lifting.
- Reverse the truck and make it be away from the carrier.
- The steps of assembly are opposite from the disassembly. If there is no side shifting carrier, move the fork bracket to the limit several times and exhaust the air in the system.

■ Mast

Before disassemble the mast, disassemble the fork bracket and fork referring to the instruction before. Disassemble the driving wheel (if needed)

1. Suspend the lifting slings to the lifting eye on the upper cross beam and lift the mast. Remove the tilt cylinder from the mast pin roll.
2. Disconnect the hydraulic pipeline from the lifting cylinder and block all open mouth in preventing foreign matters entering.



The remaining oil will be exhausted out when disconnected.

3. Tilt the mast a little forward and disassemble the assembling bolts.

The steps of assembly are opposite from the disassembly. Take care of the following notes:

- 1) Replace the cotter with new ones;
- 2) Tighten the mast locking bolts to proper torque. (refer to the maintenance data)
- 3) Lubricate all pins.
- 4) If assembly and disassembly affects the tilting angle, check and adjust the tilting angle.

3.3 Operation

3.3.1 Starting check

 **CAUTION**

Do not operate the truck until all checks are done.

If there is any abnormal, report to the manager and do not operate the fault truck until it is repaired.

Carry out the starting check for safety.

Refer to 4.2 Starting check for detail.

3.3.2 Getting on and off the truck and operation posture adjusting

■ Getting on and off the truck

 **CAUTION**

Get on or off the truck until the truck is stopped well.

It is prohibited to jump on and off the truck.

Do not grasp operation lever and steering wheel when getting on or off the truck.

Keep the handle and steps clean. And if damaged, repair it.

Do not use the handle in other applications except when getting on or off the truck.

Get on or off the truck from the left side.

Support yourself at least in three points with hand and foot when getting on or off the truck. Step on the step(3), grasp the handle with left hand (1) and grip the seat back or seat(2) when getting on and off.

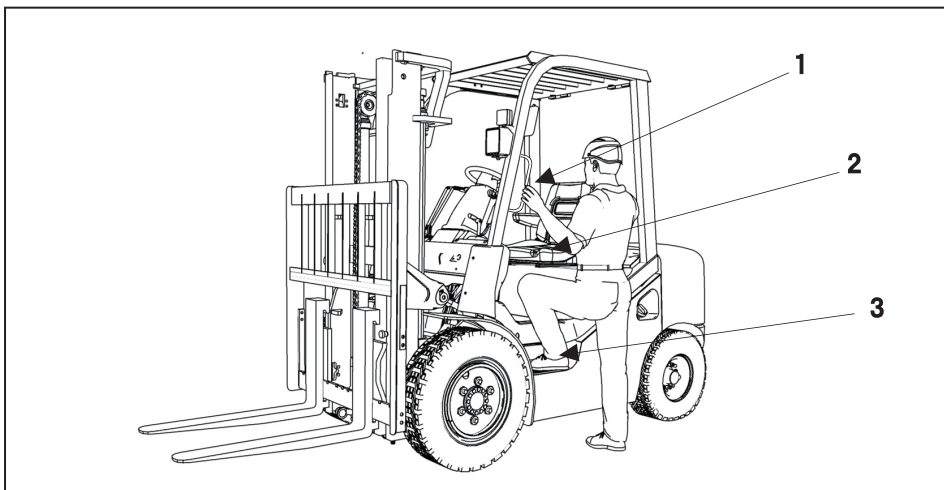

■ Seat position adjusting



Adjust the seat position before getting on the truck or changing a driver. (Adjust only the truck is well stopped.)

Make sure you can step the brake pedal fully when you lay against the seat.

1. For truck parking, refer to 3.3.8 STOPPING FOR A WHILE for detail.
2. Pull the knob to the right side when sitting on the seat. (on this position, operator can slide forward or backward when sitting on the seat.)
3. Lose the knob until the satisfied position is found and then the seat is locked.
4. Pull the seat forward or backward after adjusting to make sure the seat is locked.

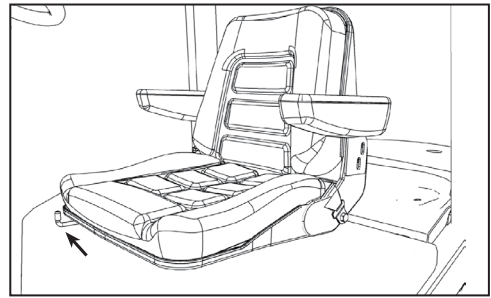

Seat back angle adjusting:

1. Rotate the knob right, the angle is increased and the back turn towards back.
2. Rotate the knob left, the angle is decreased and the back turn towards front..

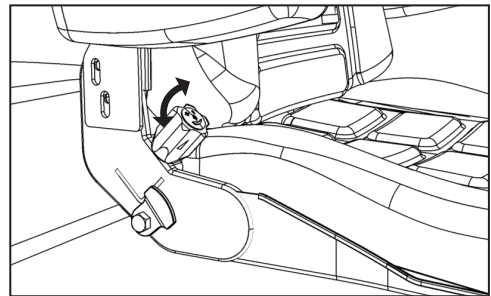

Suspension adjusting

Adjust the suspension level through adjusting knob.

Pull the knob upward if the operator is light.

Push the knob downward if the operator is heavy.

Place the knob in middle position if the operator is moderate.

Weight adjusting range: 50-120kg.

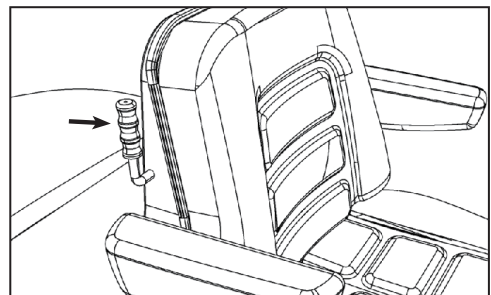

■Fasten and lose the safety belt



Wear safety belt during operation.

1. Insert the spring bolt on the left side belt to the lock on the right side. Safety belt is locked when you hear a click.
2. Hold the safety belt with left hand and press the red button on the lock with right hand when loose the belt.
3. Hold the spring bolt to roll the belt slowly.

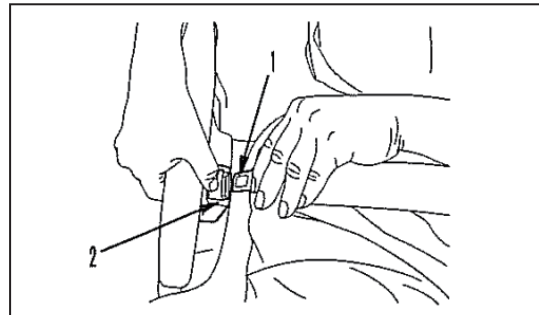
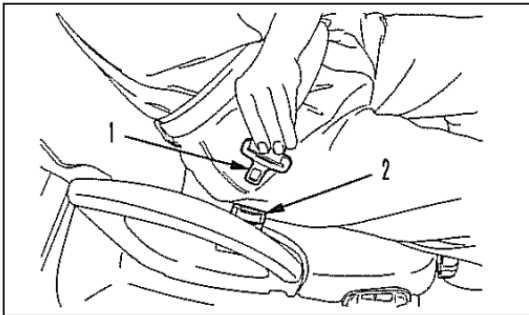

■ Steering hand wheel position adjusting



CAUTION

Park the truck well before adjusting the steering hand wheel position.
After adjusting, move the steering hand wheel forward and backward to check if it is locked.

1. Stop the truck.;
2. Lift the steering wheel lock lever to A position;
3. Move the steering wheel forward and backward to choose proper position;
4. Push the steering wheel lock lever to position B to lock the steering wheel;
5. After adjusting, check if the steering wheel is locked well.

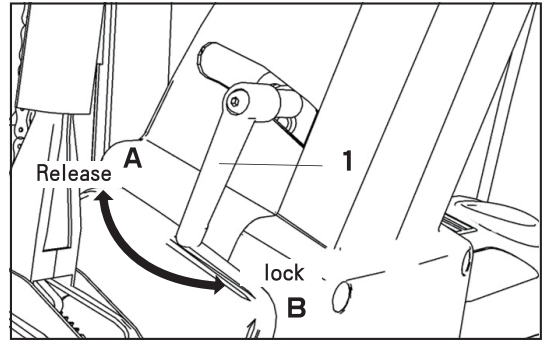

3.3.3 Starting, gear shifting and travelling

■ Engine starting



CAUTION

Never try to make the engine starting circuit short circuit on purpose to start the engine, or serious injury or fire may be caused.



CAUTION

Start the engine only when the driver sits on the seat.

Before starting the engine, place the forward/backward operation lever and high speed/low speed lever on neutral position and push the parking brake backward.

Keep the working area well ventilated when starting the engine inside or in a poor ventilated place because the exhausting air is poison.

If the truck is operated with such posture (the seat does not bear your whole weight, for example stand or lean against forward, backward or side when operating), the power to engine will be cut and the truck may slide down. In that case, accidents or collision may occur. Keep proper posture when going on a slope. (Truck with OPS seat)

1. Place forward/backward operation lever and high speed/low speed operation lever on neutral position.

Note: Engine can not be started unless the forward/backward operation lever is placed on neutral position.

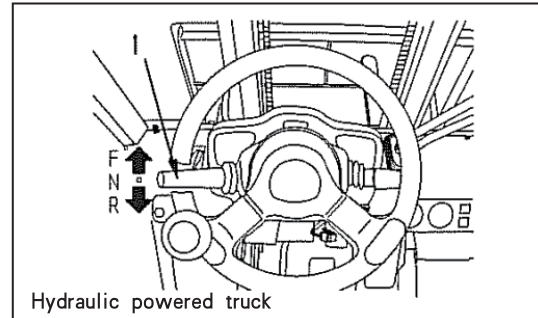
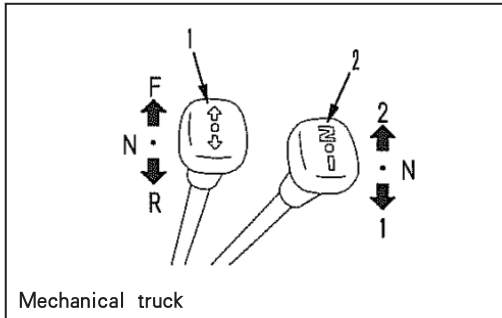

2. Releasing the parking brake

When releasing parking brake, pull the handle back and press down the button on top of the handle at the same time. Then press the button and push the handle forward at the same time to make the handle to be placed at the very leading position.

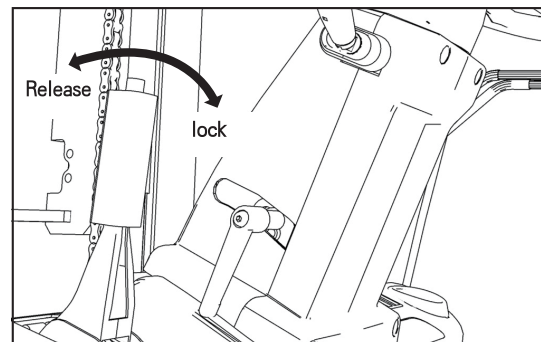

3. For hydraulic powered truck, step on the inching pedal.

For mechanical truck, step the clutch pedal fully.

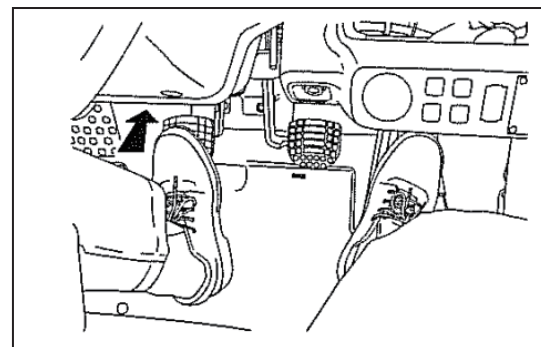

4. Starting switch operation

- Gasoline engine

Turn the starting key switch to the START position (II) when your foot move away from the acceleration pedal and then the engine will be started.

- Diesel engine

Turn the starting key switch to the ON (I) position and the preheating indicator will light on which means the engine begins to preheat. The indicator will turn off in 14 seconds showing the preheating is finished.

Turn the starting key switch to the START position (II) when step on the acceleration pedal and then the engine is started.

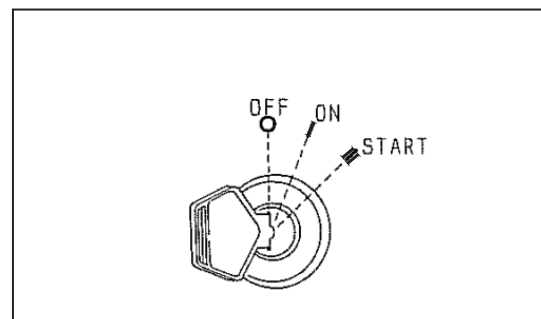

The starting key switch will go back to the ON (I) position automatically when undo the engine starting key switch as soon as the engine is started. When the engine is working, make sure the key stays at the position.

Start the engine according to the following procedures if the environment temperature is lower than -15°C (5°F) :

- (1) Turn the starting key switch to the START (II) position and start the engine for no more than 15s.
- (2) If the engine is not started after 15s, turn the key switch to OFF (o) position. After 1 minute, turn the starting key switch to the START (II) position again and start the engine for no more than 15s.
- (3) If the engine is still not started, turn the key switch to the OFF (0) position. Start the engine once again after one minute.
- (4) The engine can only be started three times continually at most. If it can not be started in three times, check the truck or contact with HELI dealer/agent for check.
 - If it is electric controlled engine, the interval between two consecutive stay on ON(I) position shall be more than 6s during switching key switch between OFF (0) position and ON (I) position.

5. Warm the engine

- Truck with gasoline engine: It will stop automatically after the engine is warm.
- Truck with diesel engine: release the acceleration pedal and go on warming the engine for a while.

IMPORTANT

- Keep the starting key switch on OFF (0) position when the engine is not working. Do not keep it on ON (I) position or battery quality will be reduced which causes the engine be hard to be start.
 - Do not make the starting motor work over 10s. (*)
 - Operate the starting motor again after 20s. (*)
 - When the engine is working, do not turn to starting key switch to the START (II) position.
- * The notes above is not suitable for the truck with diesel engine when the environment temperature is lower than -15°C .

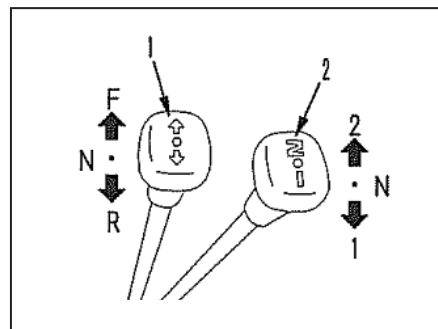

■ Drive the truck

Mechanical truck: step on the clutch pedal fully and place the forward/backward operation lever (1) to the forward (\uparrow) (F) or (\downarrow)(R) position and high speed/low speed operation lever (2) to (1) (low speed) lever.

IMPORTANT

When operate the forward/backward operation lever or high speed/low speed lever, be sure to step on the clutch pedal fully.

■ Hydraulic-powered truck

1. Step on the inching pedal and place the forward/backward operation lever to the forward (↑) (F) or (↓)(R) position.

2. Releasing the parking brake

When releasing parking brake, pull the handle back and press down the button on top of the handle at the same time. Then press the button and push the handle forward at the same time to make the handle to be placed at the very leading position.

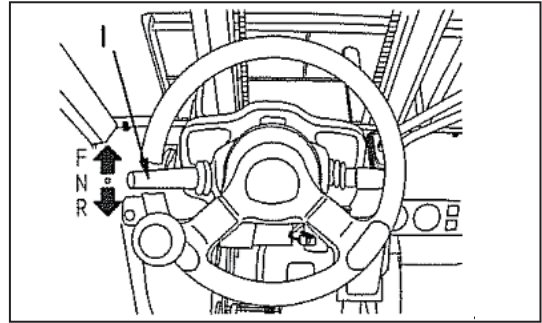

IMPORTANT

If the parking brake is not released when the truck is travelling, the brake will be overheat and worn. What is more, the brake function will be affected.

Contact with HELI dealer or agent for check if the truck travels with parking brake applied for a long distance.

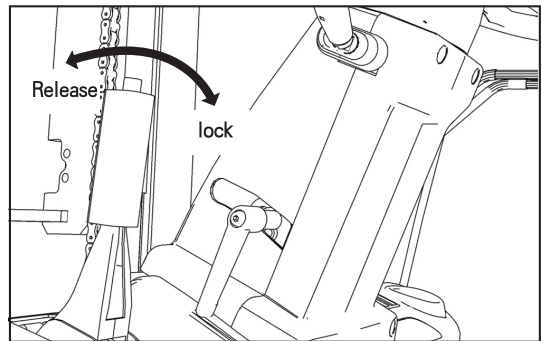

3. Check the safety around the truck and in the travelling direction.

4. Slowly release the clutch pedal (4) or inching pedal (4) when you softly step on the acceleration pedal, and then the truck will travel. Once it begins to travel, move your foot away from the clutch pedal (4) or inching pedal (4).

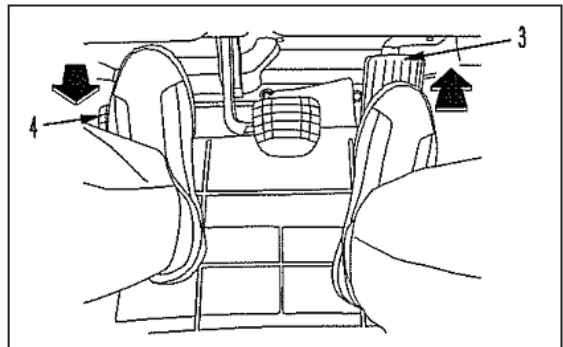

IMPORTANT

Do not stay on the clutch pedal, inching pedal or brake pedal unless it is necessary.

■ OPS (optional)

- If the seat does not bear your whole weight, for example stand or lean against forward, backward or side when operating, the safety device will prevent the truck from working. If you operate the truck with such posture, the OPS will be activated in 5s and transmission box power will be cut. In that case, the truck can not move even acceleration pedal is pressed or forward/backward lever is operated.
- When the OPS is activated, the OPS indicator on the meter will light on.
- Return to travel condition: sit on the seat with proper posture and place the forward/backward lever on neutral position and then the truck will be ready for travel. Ensure the safety around.
- The OPS only cut the power but not put the brake into effect.

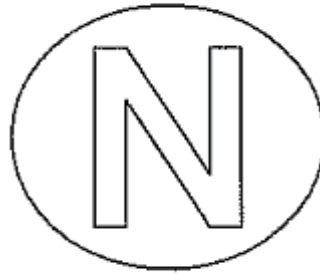

■ Gear shifting (mechanical truck)

1. Release the acceleration pedal (3) and press the clutch pedal fully (4).

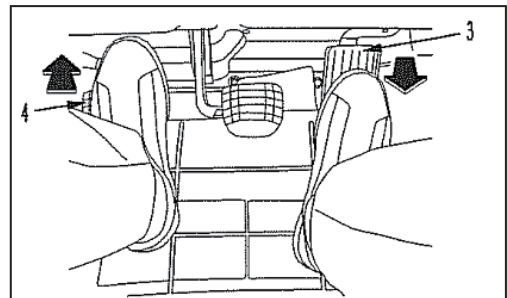

2. Place the high speed/low speed operation lever on high speed position.

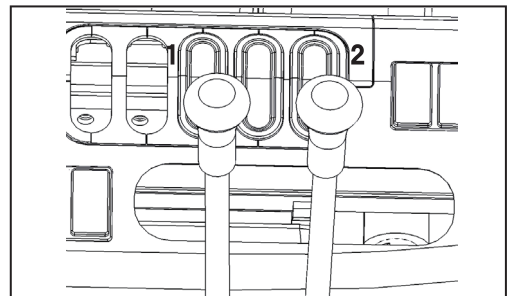

3. When the operation lever is placed on correct position, release the clutch pedal slowly after step on the acceleration pedal.

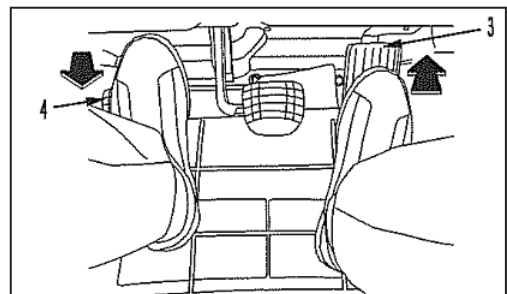

■ Direction changing

1. Release the acceleration pedal (1) and step on the brake pedal (2). Before stopping, step on the clutch pedal fully (3).
2. Before truck stopping completely, shift the forward/backward operation lever to (↓)(R) position from (↑)(F) position. For mechanical truck, shift the high speed/low speed operation lever to high speed or low speed position.

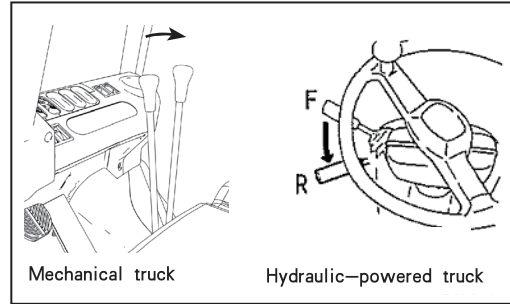
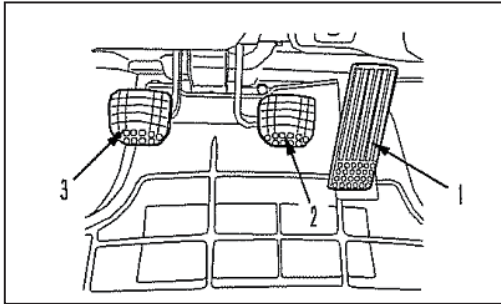

IMPORTANT

Change the direction only when the truck is completely stopped.

3.3.4 Start and stop on a slope

1. Apply the parking brake when starting on a slope.
2. Slowly release the parking brake when pressing the acceleration pedal (1) increasingly (if it is mechanical truck, release the clutch pedal), and then the truck can go uphill.
3. Release the parking brake completely when truck reaches certain speed. The going uphill speed can be controlled by the pressing distance of the acceleration pedal.
4. When stop or deceleration on a slope, release the acceleration pedal (1) slowly (If it is mechanical truck, step on the clutch pedal (3) at the same time) and step on the brake pedal at once before stopping.
5. Apply the parking brake when the truck is stopped.

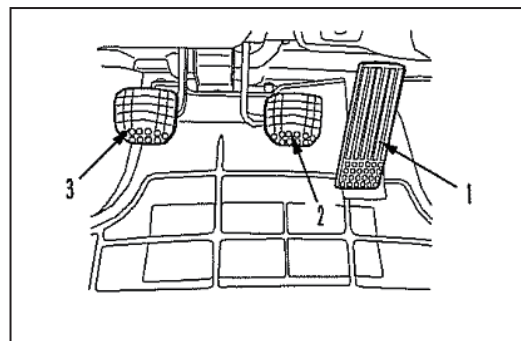
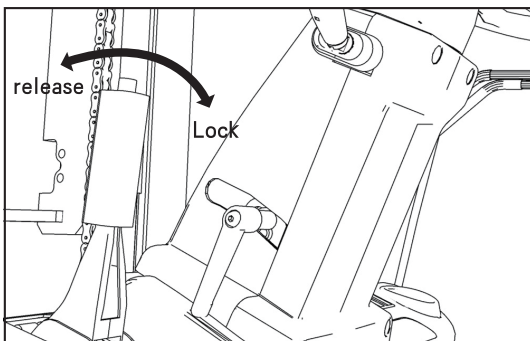

3.3.5 Inching

CAUTION

Do not make the truck inching through stepping on the acceleration pedal and adjusting brake pedal pressing distance.

Make the truck inching through half engaging the clutch pedal or inching pedal.

IMPORTANT

- Long distance travelling with clutch engaged will damage the clutch. So try to limit such travelling in 10s.
- Do not step on the clutch pedal or inching pedal all the time, or clutch may be engaged by accident and may be damaged.

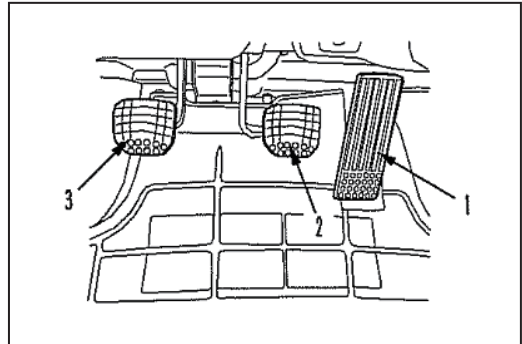

3.3.6 Steering

CAUTION

When steering, take care that the external side of the counter weight may collide with the person or object around.

The rear wheel is steering wheel. if it travels forward when steering, it is near the insides; if it travels backward when steering, it is near the outside.

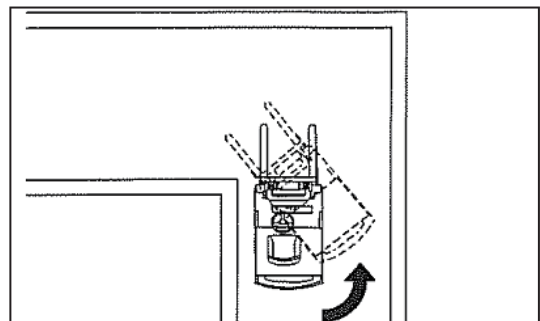

NOTE

- Turning fixedly will accelerate the wear of the tyres.
- Steering with low speed is good for tyre.

3.3.7 Operate on snow field and icy field



CAUTION

Slipping can not be prevented completely even the truck is assembled with anti-slipping tyre or chain.

Some model may not be suitable to assemble anti-slipping tyre or chain.

- When travelling on snow or icy field, assemble anti-slipping tyre or chain.
 - Avoid sudden brake, acceleration or steering on snow or icy field. Take care to operate acceleration pedal in case of slipping.
-

3.3.8 Truck deceleration and braking



CAUTION

Park the truck away from the traffic area.

1. Carry out the following operation for mechanical truck and hydraulic-powered truck

- Mechanical truck: release the acceleration pedal, press the brake pedal (1) and then press the clutch pedal (2) before stopping.
- hydraulic-powered truck: release acceleration pedal and press the brake pedal (1).

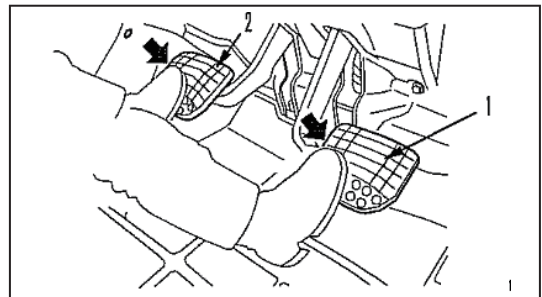

2. Apply parking brake after the truck is stopped. Before it is completely stopped, place the forward/backward operation lever and high speed/low speed operation lever (mechanical truck) to neutral position.

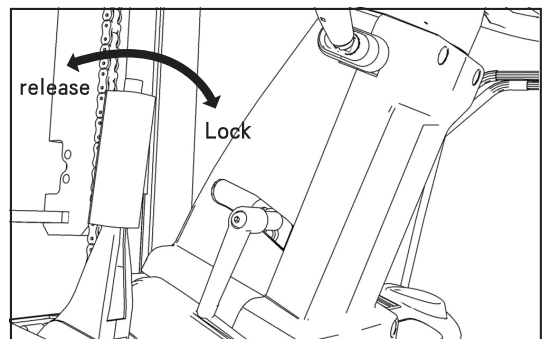

■ Truck parking procedures

1. Park the truck on flat ground.
2. Apply parking brake.
3. Place the forward/backward operation lever and high speed/low speed operation lever on neutral position.

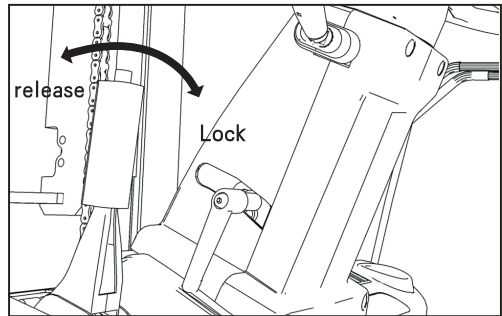

4. Tilt the mast forward and lower the fork to the ground.
5. Turn the starting key switch to OFF (0) position.
6. Draw out the key and go away from the truck.

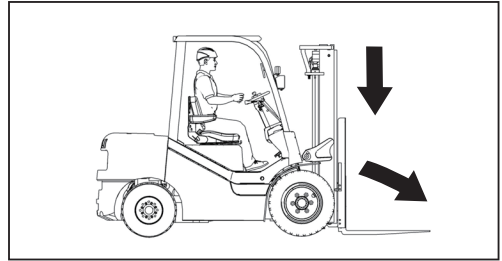

3.3.9 Load handing operation

■ Space between fork adjustment

Adjust the space between the fork before loading to suits pallet size and loads.



CAUTION

Take care not to make hand or finger be caught when adjusting.
For the forks with hydraulic fork positioning function, the adjustment of fork width shall be carried out without load. It is prohibited to adjust with load.

1. Stop the truck right before the loads.
2. Make the mast be vertical and lift the fork 10cm above the ground.
3. Tilt the mast forward.
4. Lift the fork stopper and rotate 90° to releasing position. (fork can move left or right under this condition.)
5. Adjust the space between fork according to loads size and align the loads center of gravity with the truck.
6. Make the mast be vertical and rotate the stopper 90° to the lock position. (At this time, fork is locked.)
7. After space adjusting, check if the fork is locked by stopped. If not, the fork may move towards two sides and goods may fall down when travelling.

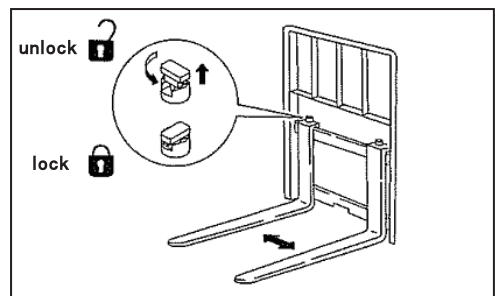

■ Operation lever



CAUTION

Sit on seat properly and ensure the safety around when operating lifting operation lever. Improper operation and even serious injury may occur if operating with improper posture or operating outside of the cab.

Lifting operation lever

Lifting: press the operation lever downward.

Lowering: push the operation lever upward.

NOTE

Lifting and lowering speed can be adjusted by the operation lever tilting degree; lifting speed can be adjusted by the pressing distance of the acceleration pedal.

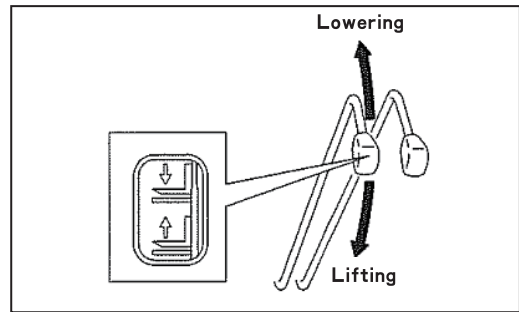

Tilting operation lever

Tilting forward: push the operation lever upward

Tilting backward: press the operation lever downward

NOTE

The fork forward and backward tilting speed can be adjusted by the operation lever tilting degree and pressing distance of the acceleration pedal.

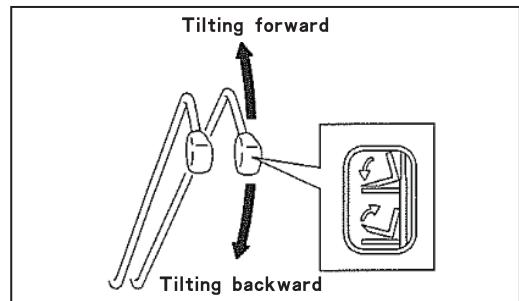

Load picking

1. Insert the fork to the load bottom.
2. if it can not be done once, drive the truck forward until 2/3-3/4 of the fork is inserted into the pallet. Then lift the load 5-10cm and drive the truck backward 10-20cm. At last, lower the load and drive the truck forward until the fork is inserted to the pallet completely.
3. Lift the load 5-10cm and drive the truck backward to where load can be lowered.

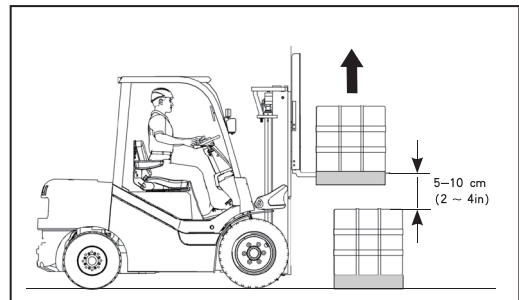

4. Lower the load to be 15-20cm above the ground and tilt the mast backward.

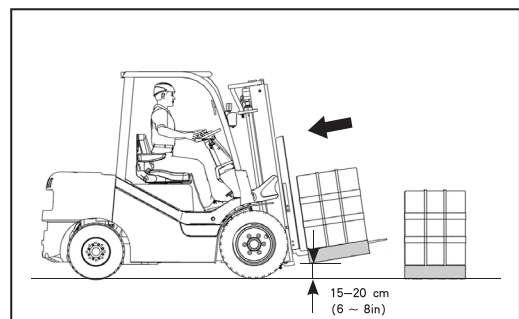

Stacking

1. Make the mast be vertical and lift the fork to be 5-10cm higher than stacking position. And then move the truck forward slowly.
2. Put the truck on desired position.
3. Draw the fork out.

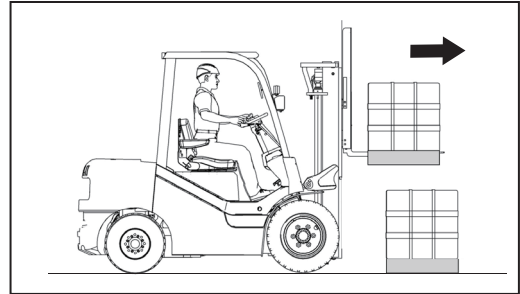

3.3.10 Notes when the truck is equipped with solid tyre

When the truck is equipped with solid tyre, please pay attention to the following notes:

- 1) The truck with solid tyre is suitable for intermittent working condition and the working radius shall not exceed 2km.
- 2) The speed of the truck with solid tyre should not exceed 25km/h and avoid to work with overload.
- 3) When working under harsh condition, and the truck are beyond the requirements above, it is suggested to reduce travelling speed and using frequency and pay attention to the tyre's temperature increase. Avoid fast increase of temperature.

3.3.11 Check after operation

Carry out all checks described above and clean the truck. Before storing, carry out the checks below:

1. Check if there is leakage of fuel, battery and electrolyte.
2. Check if there are any cracks or damage.
3. If there is any fault, report it the manager and place a mark or sign on the truck. (if necessary)
4. Lubricate the truck if necessary.

Refer the following points for other information:

- Refer to 4.6 WORKING IN COLD WEATHER for notes when working in cold weather.
- Refer to 4.7 MEASURES OF ENGINE OVERHEATING for measures when the engine is overheating.
- Refer to 4.11 STORING FOR A LONG TIME for storing for a long time.
- Refer to 4.13 LOADING AND UNLOADING for relative operation.

3.4 Transporting

Refer the technical parameter for truck size and weight.

Refer to the following figure for truck center of gravity. For more information, please contact with HELI dealer.

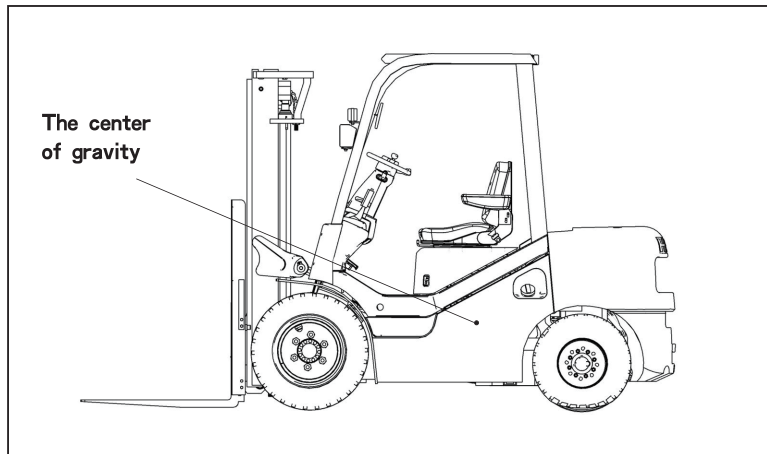

3.4.1 Truck fixing



CAUTION

Authorized transporting company is recommended to transport the truck through highway, railway and waterway.

No matter which method is chosen to transport the truck, a common fixing method is needed which can reduce the truck and paint damage possibility.

Forklift truck fixing method on a lorry:

1. Keep a proper distance (at least 10cm) between two trucks for safety during transporting.
2. Put a wood block under the rear axle surface avoiding a bad effect on rear wheel because of the large gravity of counter weight. Apply the parking brake.
3. Bind the truck carefully avoiding appearance damage. Avoid direct contact with the rope. Put a rag on each binding point.
4. when binding, chose the position which can bear large force. Usually, chose the center beam as the front fixing point and hole on the counter weight as the rear fixing point.
5. The steel rope and iron wire must not interfere with the truck important parts such as tilting cylinder, lifting cylinder avoiding deforming because of force.
6. Fix the truck according to the sketch map below in order to bear small force.
7. In principle, place the truck facing opposite the lorry travelling direction. Because a spin may be caused during travelling if center of gravity is moved to one side. According to practical condition, placement of facing the lorry travelling direction and opposite the travelling direction can be mixed. Be sure to fix the load firmly.
8. After arriving, loose the fixing steel rope when unloading. Then lift the counter weight with lifting equipment and remove the wood block. At last the truck can be driven.

Forklift truck fixing method in a container:

1. For container space limit, trucks position is compact. The min. distance between the two trucks is 20-30mm to ensure disconnecting with each one.
2. Protect the left and right sides of the frame and counter weight with felt pads before going to the container avoiding truck appearance damage.
3. Lift the counter weight with lifting device and put a metal block under it avoiding a bad effect on rear wheel because of the large gravity of counter weight. Apply the parking brake.
4. Wedge the wheels with metal blocks and fix them to the floor board of container for safety.
5. Bind the truck carefully avoiding appearance damage.
6. Chose the lifting holes on top of the mast as front fixing points. For the outside, connect the listing hole with the hook on container. For the middle, connect the two trucks' lifting holes with steel wire. And connect the fork cross beam with the lower hook on the container. Chose the traction pins on the counter weight as rear fixing points. For the outside, connect the pin with the lower hook on the container. For the middle, connect the two trucks' pins with steel wire.
7. When binding, put rag or felt pad to protect the paint on the fixing point from damage.
8. After arriving, loose the fixing steel rope when unloading. Remove the wheel blocks. Lift the counter weight with lifting equipment and remove the metal block. At last the truck can be driven.
9. In principle, trucks should be placed side by side. Placement of facing the travelling direction and opposite the travelling direction can be mixed or placement of facing the travelling direction. Be sure to fix the load firmly.

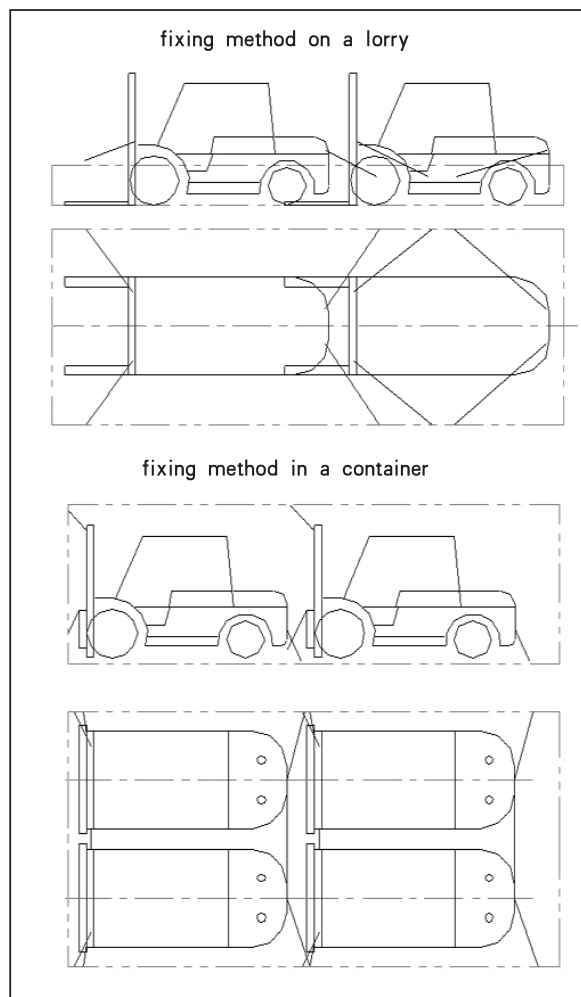

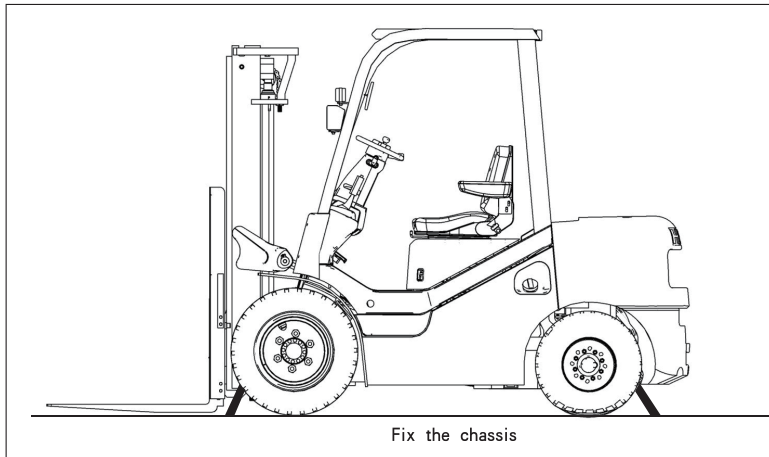

3.4.2 Mast transporting and reassembling

Some mast has to be disassembled during transporting for height limit.

1. Seal the hydraulic pipeline disassembling ends after disassembly. Fix the pipelines with belts. Wrap the connectors and transport with the whole truck.
2. Reassemble the mast after arriving by professionals.

Main technical requirements are followed:

(1) Mast assembly

- a. Check the clearance between the mast and side rollers.
- b. connection between the mast support and frame: apply lubricating grease to bushing. The tighten torque of the mast support bolts: 83Nm. Apply anaerobic adhesive GY-340.
- c. Assembly of the tilting cylinder ear fixing bolts: tighten torque 120Nm. Apply anaerobic adhesive GY-340 (do after mast tilting angle adjustment and check).
- d. The connection and moving trend of pipelines are reasonable. Fix the pipeline with clamps

(2) After mast assembly

- a. Check the mast tilt angle referring to the parameters;
- b. Adjust the chain tensinty after reassembly.
- c. The pipeline can not interfere with the mast moving.

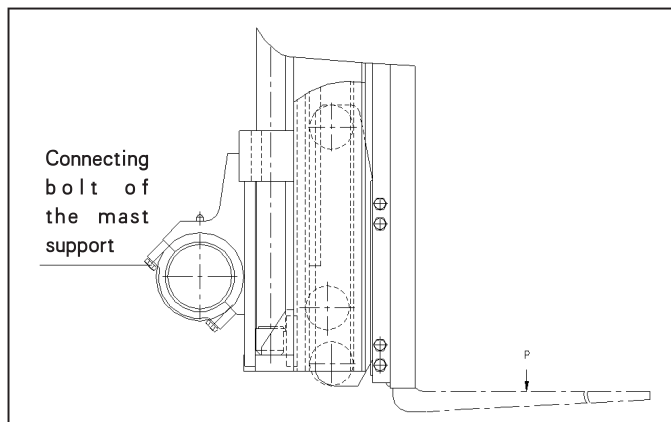

Connecting bolt of the mast support

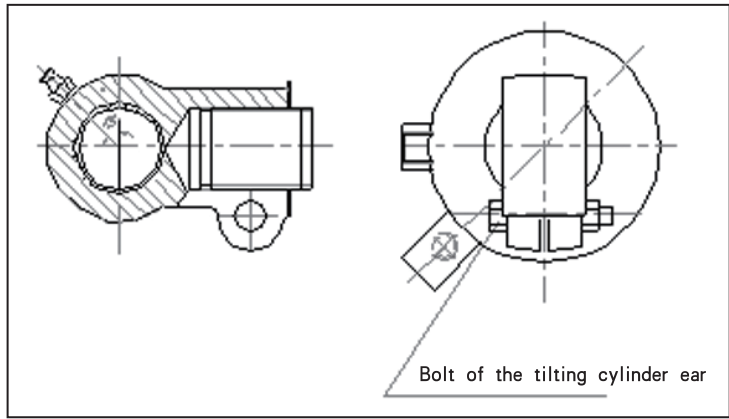

The disassembled mast usually is transported through horizontal method. Place the mast into the container vertically by special clamp in particular. When loading, refer to the practical space. Fix the mast to the middle hook in the container. Block the connecting point between mast support half and the floor board avoiding damage to the container floor.

■ Electricity and hydraulic connection

Block all connecting points of the electricity and hydraulic system in disconnecting condition.

Lifting

The lifting plate shown in the figure shows the proper lifting points. The points are on the mast and counter weight.

For more information, contact with HELI dealer or agent.

IMPORTANT

Make sure all slings have the safe capacity to lift up the truck.

Make sure the mast is under vertical condition before lifting up the truck.

■ Lifting the truck

Put proper lifting equipment on the lifting points.

1. Put sealing material where the lifting equipment may connect the truck avoiding appearance damage.
2. Tighten the slack rope and be away from the truck.
3. Carry out one lifting test to ensure balance lifting. If not, lower to the ground and adjust the lifting equipment.
4. If all above descriptions are correct, lift the truck to required position slowly.
5. Place the truck to required place and remove the lifting equipment.

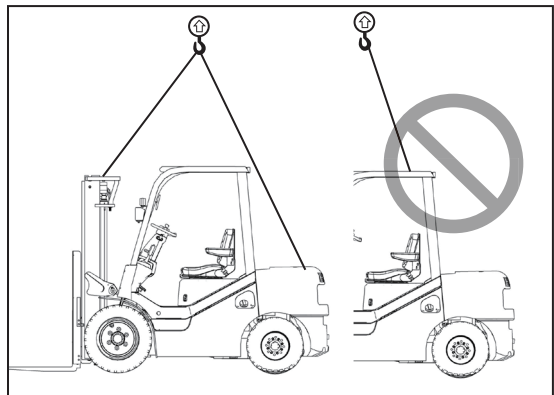

Sling plate

CHECKING AND MAINTENANCE



WARNING

Please read the manual and safety notes carefully.

When checking and maintaining the truck, please follow the safety notes or serious injuries may be caused.

4.1 About checking and maintenance

Starting check, oil change, filter cleaning and other simple maintenance work are described below. For others that are not described, contact with HELI dealer or agent.

Refer to the second chapter SAFETY NOTE for safe checking and maintenance.

Improper maintenance and repair may cause serious accident and shorten truck service life. Please contact with HELI dealer or agent for maintenance and repair.

4.2 Starting checking



CAUTION

- Do not operate the truck before checking.
 - If there is any abnormal, report to the manager. Do not operate the truck until it is repaired.
-

- For safety, carry out the starting check before operation.
- Record checking results in checking record.

Starting checking parts table

Item	Checking parts
—	Check the abnormal found the day before
Forklift truck	Leakage of oil and electrolyte
	Crack, damage and fixing condition (overhead guard, fork, backrest and so on)
	Tightness of the locking nut of the tilting cylinder piston rod
	Check if the light and glass cover are clean or damaged.
	Check if the backview mirror and truck plate are clean or damaged.
	Check the tightness of hub nuts.
	Check if the tyre and rims are damaged or out of shape.
	Check the inflation pressure.
Open the engine hood	Hydraulic oil level
	Engine oil level and check if it is dirty.
	Check the tightness of the battery connection.
	Coolant level
	Brake liquid level
Sit on seat	Performance of the safety belt
	Seat and hand shark
	Brake pedal clearance and height
	clearance and height of clutch pedal and inching pedal
	Parking brake operation lever operation force
	Horn
	Cleanness, damage and angle of the backview mirror
Turn the starting switch to ON position	Alarming indicator on the meter (check through switch the starting switch to ON and OFF position)
	Light
	Fuel level
Start the engine	Abnormal noise and vibration
	Exhausting air color
	Hand wheel clearance
Drive slowly	Hand wheel operation condition (radial run-out and unstable driving)
	Brake operation condition (respond)
	Inching and clutch pedal operation condition

Item	Checking parts
Load handling	Mast operation condition
	Tightness of lifting chain; check if it is damaged or rust.
Safety function check	OPS (hydraulic-powered truck)
	Parking brake

4.2.1 Check the abnormal found the day before

Check the abnormal found the day before. Make sure there is no fault.

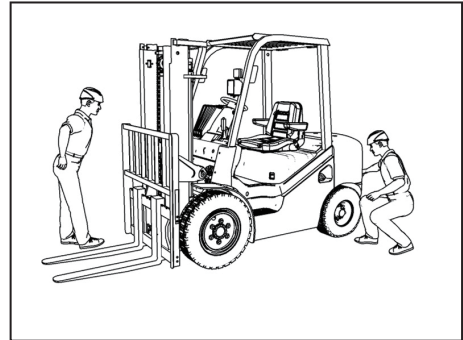

4.2.2 Forklift truck

- Check if there is leakage of oil and electrolyte.
 - Check if there is leakage of oil, fuel, coolant and battery electrolyte.
 - check if there is leakage of oil and electrolyte under the truck.

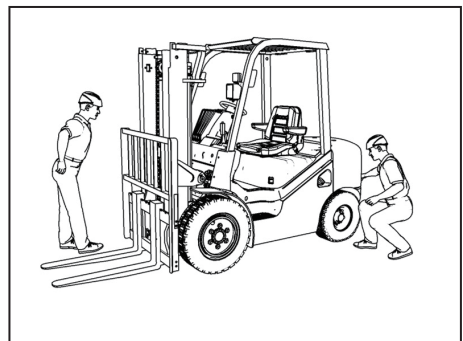

■ Crack, damage and fixing condition check

Check if there is any damage, cracks, loose and clearance through visual check. Check the following parts preferentially:

- Overhead guard
- Fork
- Backrest
- Fork bracket
- Mast
- Fuel tank
- Hydraulic oil tank

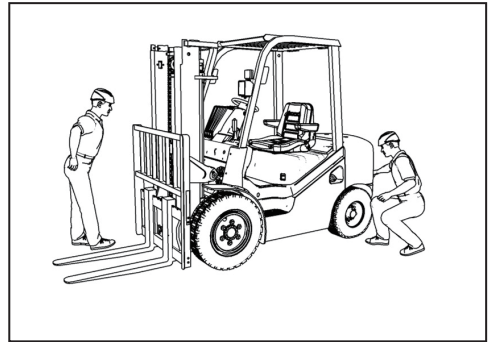

■ Check the tightness of the locking nut of the tilting cylinder piston rod

Check if the tilting cylinder piston rod, piston head and locking nut are loose visually.

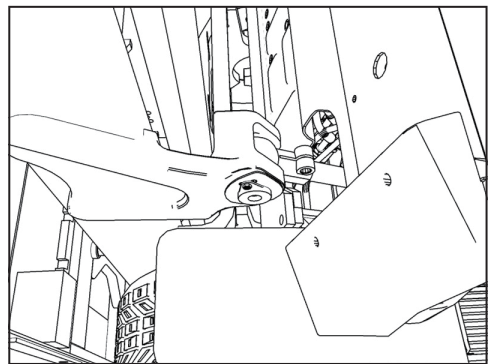

■ Check if the light and glass cover are clean or damaged.

Check if the light and glass cover are clean or damaged visually.

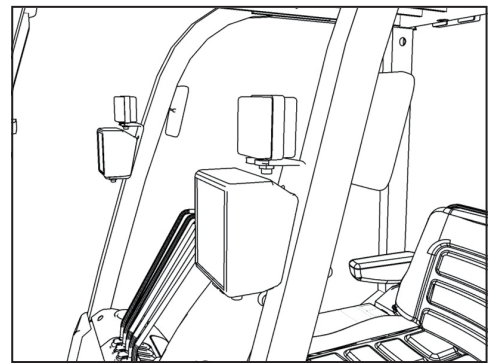

■ Check if the backview mirror is dirty or damaged.

Check if the backview mirror is dirty or damaged visually.

- Check if the rim nut is loose.

Check if there is loose nut by wrench.

IMPORTANT

Tighten the rim nut to the regulated torque.

For proper tighten torque, refer to 4.16 REPAIR PARAMETER.

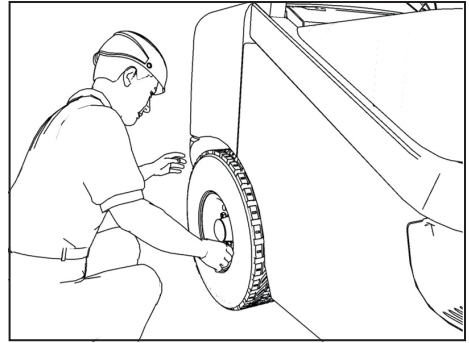

- Tyre and rim checking

- Check if the tyres are worn, damaged. Check if there is any adhered nail and other foreign matters. Check if the rim is out of shape or damaged.
- If the rim tread depth is less than 5mm or there is tyre worn alarming mark, change the tyre.

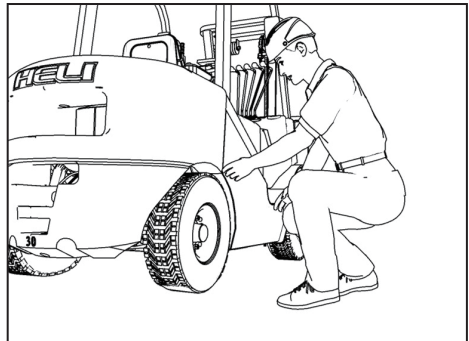

- Check the tyre inflation pressure.



CAUTION

There is high pressure inside the tyre. When checking inflation pressure, face the tyre thread surface (refer to the figure) and hold the tyre inflation gauge. Check the inflation pressure with inflation gauge and adjust it to regulated value. Refer 4.16 REPAIR PARAMETER for inflation pressure.

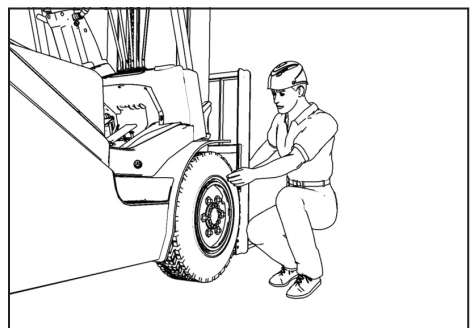

4.2.3 Open the engine hood to check

CAUTION

- Before opening the engine hood, shut off the engine.
- Take care not to press your hand when opening or closing the engine hood.
- Only authorized person is allowed to open the engine hood.

1. Release the hood lock through pushing the hand shank on the left front of the engine hood.
2. Push then engine hood upward until the red stopper of the engine hood supporting gas spring is taken its place.

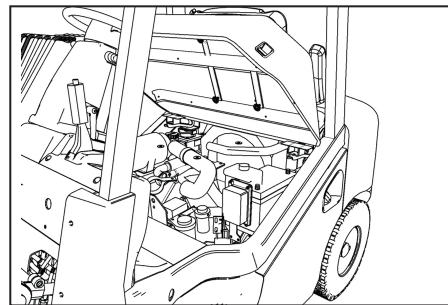
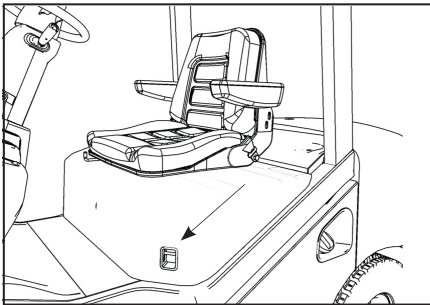

■ Methods of closing the engine hood

- Press the support's red stopper (marked with press) to the direction of arrow (backward) with one hand and close the engine hood with the other hand slowly.
- Check if the engine hood is closed and locked.

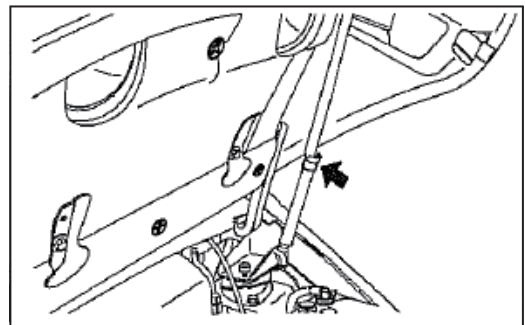

■ Hydraulic oil level check

Check if the hydraulic oil is added to regulated level.

1. Place the truck on a flat ground. Lower the fork to the ground and keep the mast be vertical.
2. Draw out the oil dipstick on the right side of the truck (integrated with the ventilating device). Clean the oil dipstick with rag and then insert it to the oil tank.
3. Draw out the oil dipstick and check if the adhered oil is in normal range.
4. Add oil if oil level is low; if oil run out, clean it.

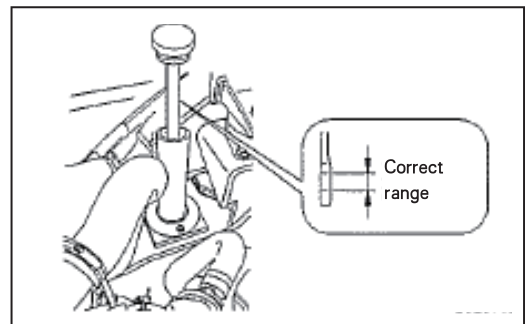

IMPORTANT

- Only pure HELI hydraulic oil or recommended oil can be used.

- 1-5t truck hydraulic oil level gauge instruction

For different lifting system, please refer to corresponding scale mark. Please refer to face A when the lifting system is normal mast, its lifting height is lower than 4700mm and there is no attachment. Or else please refer to face B. H and L are marked on face A and B to show the highest level and lowest level. The oil shall stay between the two levels.

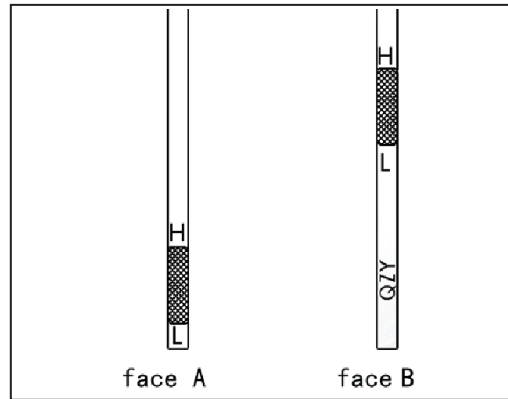

1-5t truck oil level gauge diagram

■ Engine oil level check

1. Check if the engine oil is in normal range.
2. Draw out the oil dipstick on the left side of the truck. Clean the oil dipstick with rag and then insert it to the oil tank.
3. Draw out the oil dipstick and check if the adhered oil is in normal range.
4. Add oil if oil level is low; if oil run out, clean it.

IMPORTANT

If the engine oil is polluted or goes color, change the engine oil.
Only pure HELI engine oil or recommended oil can be used.

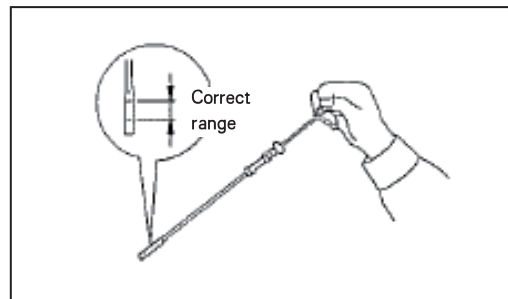

■ Electrolyte level check

 **CAUTION**

Flammable hydrogen produced by the battery is explosive. Dilute sulphuric acid is also contained in the electrolyte. Serious injuries, explosion and fire may be caused if it is handle improperly. Stick the notes described in 2.7.14 NOTES WHEN DEALING WITH BATTERY.

- Keep the ventilation device and battery terminals clean. Make sure there is no adhered dust.

IMPORTEANT

- If the battery electrolyte runs out, replace with the same type electrolyte.

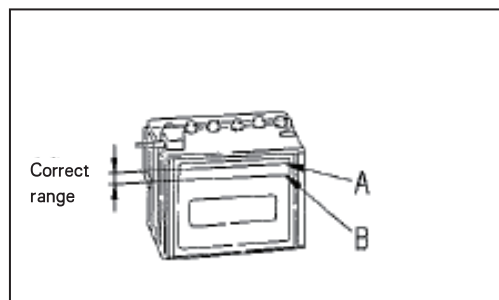

■ Coolant level check

CAUTION

Do not open the radiator cap as soon as the truck is stopped. Because the coolant temperature is very high, burning water may ejected out and burn others. Slowly remove the radiator cap slowly after the coolant is cool.

1. Check if the coolant in the auxiliary radiator stays between the FULL and LOW mark when the coolant is cool.

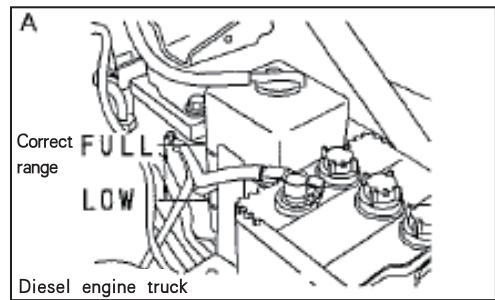

2. If the level is low, add it to the full position.
3. Check if the radiator and radiator hose leak.
4. When the coolant in auxiliary radiator runs over, open the radiator cap and add coolant to the radiator and auxiliary radiator.

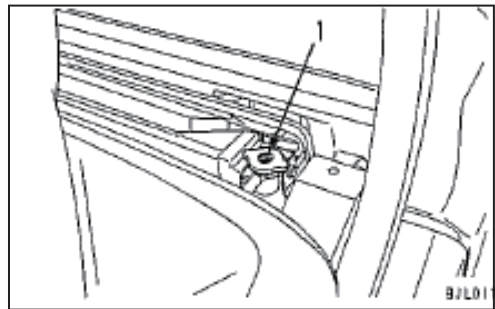

■ Check the V belt's deflation

For the V belt tension check, press the middle of the belt with 98N.

The belt deflation should be 10-13mm.

NOTE:

Change the belt if it is stretched and there is no adjusting possibility or it is damaged.

Please contact with HELI dealer or agent for belt change.

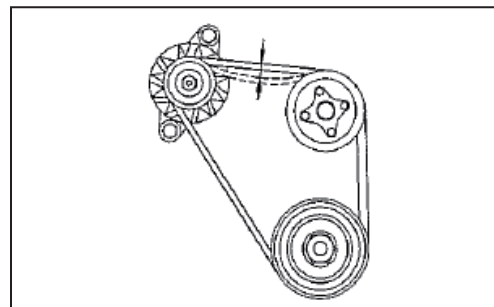

■ Brake liquid level check



WARNING

Brake liquid may leak and brake may be badly affected if brake liquid is improperly used. Use regulated brake liquid (non-mineral oil brake liquid for truck).

1. Open the cap on the left side of the cabinet and check the brake liquid level.
2. Check if the liquid stays between the MAX and MIN. if it is low, add to the upper limit.

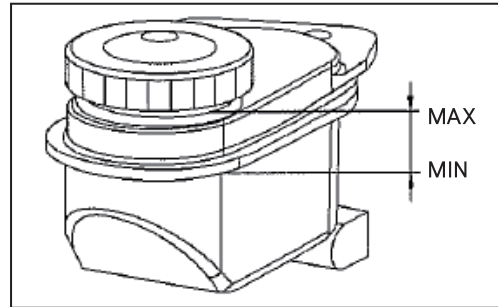
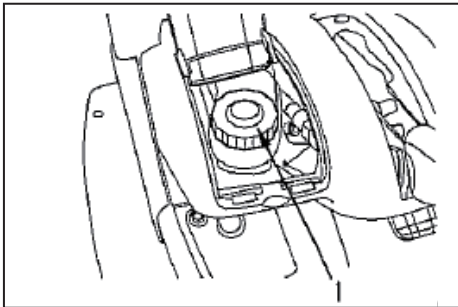

IMPORTANT

Take care not to let sand and dust fall into the brake liquid tank when adding.

4.2.4 Check sitting on the chair

■ Safety belt check

Check the safety belt first.

- Check if the belt and connectors are damaged.
- Check if the belt can be pulled out and withdrawn smoothly; check if the connector can be locked or loosen normally.
- Check if the belt can be locked when pulling suddenly.

■ Check the position of the seat and steering hand wheel.

Check if pedals, operation levers and switches can be operated stably when sitting on seat.

■ Brake pedal check

Check if the brake pedal operation force and pedal distance are correct.

Refer to 4.16 REPAIR PARAMETER for clearance standard value (S1) and pedal height (H) during brake.

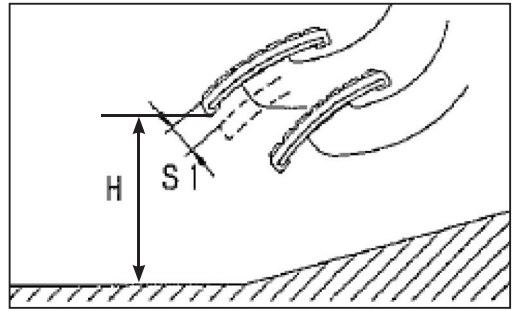

■ Inching pedal check (hydraulic-powered truck)

Check the inching pedal operation force, clearance and interlocking distance. Refer to 4.16 REPAIR PARAMETER for clearance standard value (S2) and interlocking distance (S3).

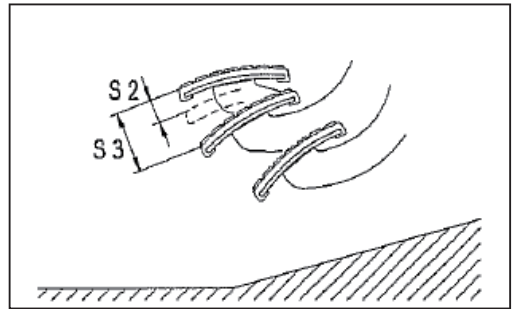

■ Clutch pedal check (mechanical truck)

Check the working condition of clutch pedal and its clearance. Refer to 4.16 REPAIR PARAMETER for clearance standard value (S4).

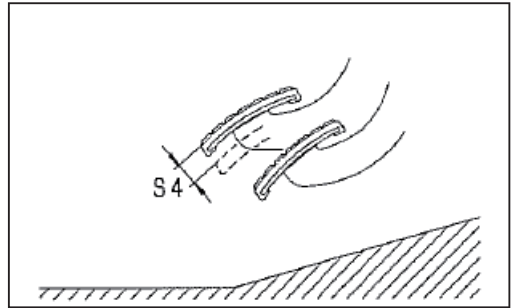

■ Parking brake handle check

Check if the parking brake handle can be pulled back to the lock position; check if the parking brake can be pushed to the released position smoothly. Check if the button can return to initial position smoothly after pressed. For parking brake handle operation force standard value, refer to “parking brake handle operation force adjustment”.

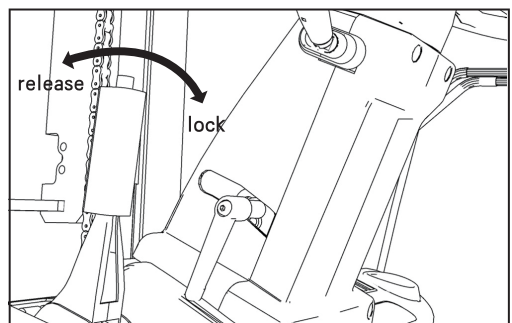

■ Horn check

Check if the horn can sound normally.

■ Rear mirror check

Check if the driver can see the rear view easily from the rear mirror. Check if it is dirty or damaged.



4.2.5 Check when the starting key switch is on ON position

■ Alarm indicator check

When the starting switch stays on ON position, check if indicators (engine oil pressure alarm indicator and no charging alarm indicator) are on.

If it is electric controlled engine, at this time, engine

fault indicator



will turn on as well.

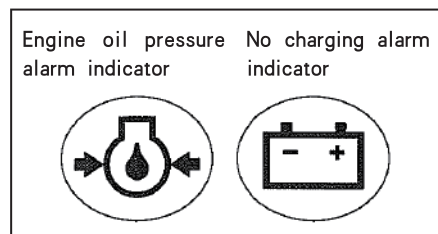

■ Neutral position indicator

If the indicator turns on when the starting switch is on ON position and it turns off when the forward/backward operation lever is on forward or backward position, the neutral indicator is ok.



■ Engine coolant temperature meter

When the engine is cold, the pointer points to the left side and when the engine is preheated, the pointer points to the white range.

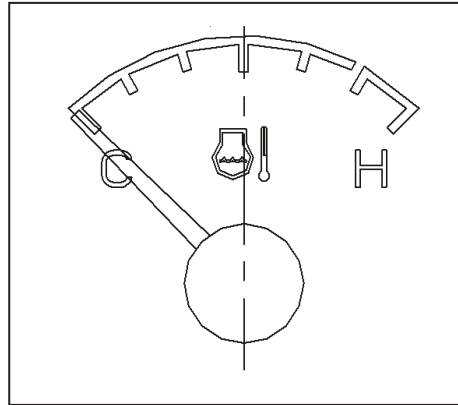

■ oil-water separator alarm indicator ((it is used as fault indicator.)(Truck with diesel engine)

- The indicator is ok if it turns on when the engine starting key switch is turned to ON position and it turns off when the engine is started.
- Drain the water in oil-water separator if the indicator still lights on when the engine is started.

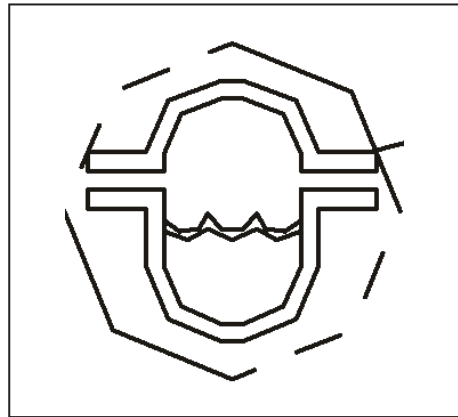

■ Lights check

- Check if the front lamp, contour light, steering signal, brake light and reversing light are normal.

■ Fuel level check and adding



CAUTION

- Before fuel adding, shut off the engine and be away from the open flame.
 - Do not let the fuel run out when adding fuel, or fire may be caused. If it runs out, clean it.
-

- Check the fuel meter and make sure if it is enough for one day's work.

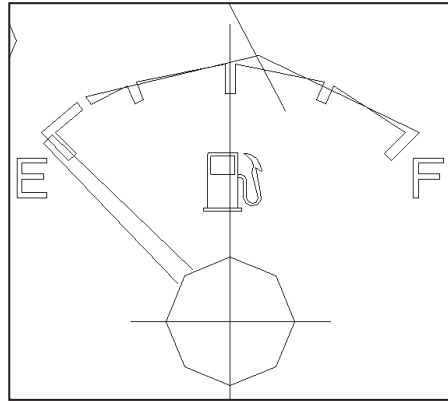

- If the pointer points to F, the tank is full.
- if the fuel level is low, shut off the engine and add fuel from the adding point. Refer to OIL TYPE TABLE for fuel type.
- When adding fuel, clean the oil sluge in and around oil adding cap protecting dirt from falling into the tank.
- After adding, tighten the oil adding cap and clean the oil running out.

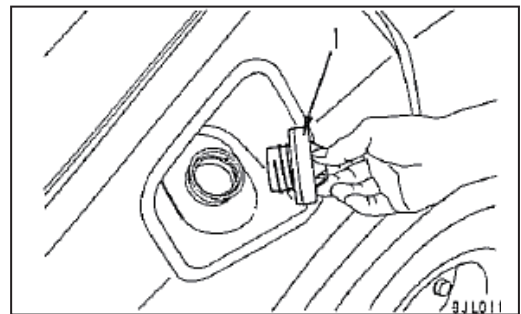

IMPORTANT

Never use the fuel mixed with kerosene in truck assembled with diesel engine because such fuel will facilitate the aging of fuel injection system.

The table below lists the corresponding oil level:

Truck model	Middle position (L)	Full (L)
1-1.8t	19	38
2-3.5t	30	60

■ Back buzzer check

Check if the back buzzer sounds when the operation lever is placed on backward position.

4.2.6 Check when the engine is started



CAUTION

- Take care of the ventilation condition when starting engine indoor or in poor ventilated place because the exhausting air is poison.
-

■ Alarm indicator on the meter

- Check if the alarm indicator on the meter turns off as soon as the engine is started.
- Engine pressure alarm indicator may turns off a little later. But that does not mean the indicator has fault.
- If it is electric controlled engine, please stop for a check or contact with local dealer if fault indicator turns on or there is fault code. it is suggested not to start the engine until the fault is removed.

■ Abnormal noise and vibration

- Especially check if the engine and hydraulic pump has abnormal noise and vibration.

■ Exhausting air color

- Check if the exhausting air is black or white.

NOTE

- For diesel engine, the exhausting air may be black or white. It is normal.
- The black and white exhausting air is caused by:

Black: incompletely burning;

White: low engine temperature or fuel mixed with water

■ Clearance check

- Rotate the steering wheel to check the clearance. If it is between 10-15°, it is normal.
- Check if it is loose through shake in both vertical and horizontal direction.

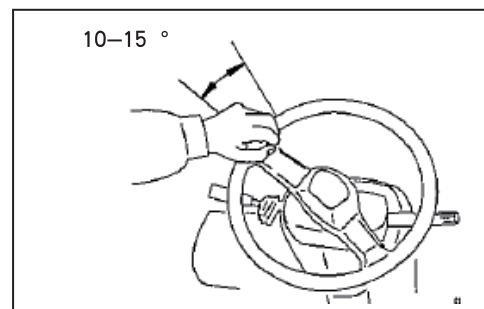

4.2.7 Check when travelling slowly

■ Steering wheel check

Check the steering wheel when driving slowly:

- Check if there is clearance;
- Check if the steering wheel is stable in left and right side when driving straightly;
- Check if the steering wheel is heavy or if there is abnormal shake when rotating the steering wheel.

■ Brake check

Check the brake respond through stepping on the brake pedal when driving slowly.

- Check if brake can meet the requirements.
- Check if the brake forces on two sides are equal.

■ Inching pedal check (hydraulic powered truck)

Check its function through stepping on the inching pedal when driving slowly.

- Check if travelling speed can be adjusted according to pressure applied on the inching pedal.
- Check if the truck can be stopped completely when the inching pedal is pressed down fully.

■ Clutch pedal check (mechanical truck)

Check its function through stepping on the clutch pedal when driving slowly.

- Check if travelling speed can be adjusted according to pressure applied on the clutch pedal.
- When the pedal is pressed down fully, clutch is released completely and if it slips when operated.

■ Abnormal noise and smell check

- Make sure there is no abnormal noise and smell when travelling slowly.
-

4.2.8 Check through operating the working devices operation lever

■ Mast, abnormal noise and smell check

• Check if the fork can be lifted or lowered smoothly and mast can tilt forward and backward smoothly when operating the levers. Before everyday working, operate the piston fully 2 or 3 times.

- When operating working devices operation lever, make sure there is no abnormal noise and smell.

■ Chain tension check



CAUTION

- If the chain tension is not equal on left and right side, then the load will be applied on one side. In that case, the chain may be broken and goods may fall down and then truck may tip over.
- Before checking, place the forward/backward lever on neutral position, apply the parking brake, shut off the engine and get down from the engine avoiding truck uncontrolled moving and check person being caught.
- Never put feet under the fork for they may be pressed.

1. Lift the fork 5-10cm above the ground (A).
2. Press the middle of the chain with finger to check if the tension are equal on left and right side.

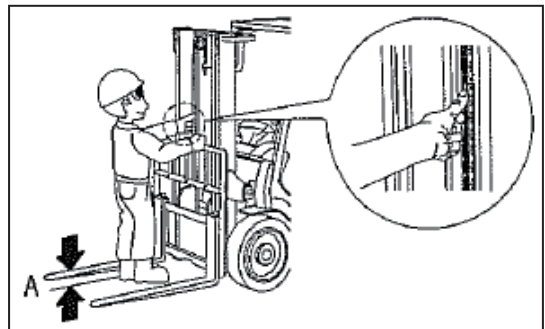

■ Lifting chain check



CAUTION

- If the lifting chain is broken, the goods may fall down or truck may tip over. If there is any fault with the chain, contact with HELI dealer/agent to replace the lifting chain.
- Rust on the chain is the main cause of chain damage, so keep the chain from rusting in early stage.

1. Check if the chain is damaged, broken or rusted through visual check.
2. Check the lubricating condition. If the chain is rusted or poor lubricated, coat the chain with engine oil.

■ Accessories, abnormal noise and smell check (truck with accessories)

Check the accessories referring to the relative operation manual.

4.2.9 Safety function check



CAUTION

- Park the truck on a flat ground before carrying out the check.
- Make sure there are no people and barriers around and there is enough driving space.

■ OPS (travelling function) check (hydraulic-powered truck)

The truck is not allowed to move by the OPS system when the driver goes away from the seat. Check the safety function.

■ Checking steps

1. Park the truck on a flat and solid ground and apply the parking brake.
2. Place the forward/backward operation lever on neutral position and lift the fork 15cm above the ground.
3. Move foot way from the brake pedal, inching pedal and acceleration pedal.
4. Place the forward / backward operation lever on forward or backward position and move you buttock away from the seat.
5. Check if the OPS alarm indicator on the meter lights on after 5s.
6. Release the parking brake.
7. Make sure the truck will not move when you press the acceleration pedal with buttock away from the seat.
8. Release the OPS (driving function).

Sit on the seat with correct posture and place the forward/backward operation lever on neutral position. The truck will return to normal operation condition and the flickering OPS alarm indicator turns off.

■ OPS (loading function) check

The truck is not allowed to lift by the OPS system when the driver goes away from the seat. Check the safety function.

■ Checking steps

1. Park the truck on a flat and solid ground and apply the parking brake.
2. Place the forward/backward operation lever on neutral position and lift the fork 1m from the ground.
3. Move foot way from pedals and move your buttock from the seat.
4. Check if the OPS alarm indicator on the meter lights on after 5s.
5. Ensure the following points:

Fork will not be lifted or lowered even the lifting and lowering operation lever is operated.

Mast will not tilt forward or backward even the tilting operation lever is operated.

6. Release OPS (loading function)

The truck will return to normal operation condition and the flickering OPS alarm indicator turns off when sitting on the seat with correct posture.

■ Neutral position safety function check

The function is used to avoid truck moving suddenly when starting the engine as the forward/backward operation lever is placed on forward or backward position.

■ Checking steps

1. Park the truck on a flat and solid ground and apply parking brake.
2. Place the forward/backward operation lever on neutral position and shut off the engine.
3. Make sure the starting motor and engine do not work even starting switch is turned to starting position when the forward/backward operation lever is placed on forward or backward position.
4. Release the neutral position safety function.

Place the forward/backward lever on neutral position after checking. Then the function is released and engine returns to normal condition. The engine will start when the starting key switch is turned to starting position.

■ Alarm buzzer on no applying of parking brake check

■ checking steps

1. Place the truck on a flat and solid ground and apply parking brake.
2. Place the forward/backward operation lever on neutral position and lower the fork to the ground. Tilt the mast forward until the fork contact with ground.
3. Shut off the engine and draw out the key switch. Release the parking brake and go away from the seat.

4.3 Check after operation and report

Check after operation and report everyday are important things which is helpful for next day's operating preparation. Before clean and store the truck after operation, check the following points and report to the manager.

1. Check if the engine oil and electrolyte leaks.
2. Check if there are cracked, damaged or loose parts.
3. Lubricate parts if necessary.
4. Check the abnormal parts found during operation.

4.4 Simple maintenance

4.4.1 Lubricating grease and fuel

4.4.1.1 Notes

When lubricating according to STARTING CHECK and CHECK AFTER OPERATION, please understand the following notes.



CAUTION

- Do not check the pipeline or hose with hand directly when checking if there is leakage because the pressure may be applied and danger may be caused.
- If your skin or eye is harmed by high pressure oil, wash with clean water at once and go to see a doctor.
- Please let HELI dealer to carry out the visual checking items except the leakage.

• Engine oil, hydraulic oil, transmission oil and gear oil that used under bad condition (high temperature and high pressure will go bad as time pass by. Change the oil regularly referring to OIL AND GREASE and LUBRICATING CHART.



- Change the oil in regulated time even it does not go bad.
- Be sure to use HELI specified engine oil. Oil listed in the OIL TYPE TABLE is filled in the truck before delivery.
- Do not use oil mixing with different degrees and numbers.
- Most fault may be caused if foreign matter goes into oil or grease. Take care not to let foreign matters fall into oil or grease during storing and lubricating.
- Add oil with proper quantity because fault may be caused because of insufficient oil or too much oil.
- If the hydraulic oil becomes turbid or there is possibility of air or water going into oil, fault may be caused if measures are not taken. In that case, please contact with HELI dealer or agent.
- When changing oil, change the corresponding filter. Please contact with HELI dealer or agent for oil and filter changing.

■ Fuel



CAUTION

Only HELI specified fuel is allowed to be used or the cleanness of the exhausting air can not meet the standard requirement. For your health and environment, use HELI specified fuel.

- Add the fuel to the full level after one day's work. Reducing the air in the tank is helpful to reduce the possibility of moisture mixed into the fuel.
- Fuel pump which is precise instrument may not work if fuel mixed with moisture or impurity is used. Take care not to let moisture and impurity mixed into fuel during storing and lubricating.
- Only fuel listed in the OIL TYPE TABLE can be used.
- Clean the fuel circuit when the fuel is over or filter is changed.

■ Coolant



CAUTION

- The coolant temperature is very high when the engine is stopped and there is high pressure inside the radiator. Do not remove the radiator's cap in this case or serious burn may be caused. Rotate the cap slowly before remove it so as to release the pressure when the coolant temperature is lowered.
- Please use new HELI special coolant. It is prohibited to add hard water such as tap water, mineral water, river water, well water to the cooling system avoiding radiator corrosion or scale forming which will reduce radiator performance and service life.
- The coolant filled in the truck can not only protect the truck against freezing above -35°C , but also protect the cooling system from corrosion, scale-forming and increase the coolant boiling point remarkable.
- Change the coolant once a year. If the coolant is bad in less than one year, change it when necessary. When changing the coolant, clean the interior of the cooling system. The freezing point of the coolant should be at least 10°C lower than the lowest environment temperature.

■ Lubricating grease

- The lubricating grease is used to prevent the connecting parts from lock, rust and producing noise.
- Only recommended lubricating grease is to be used and lubricate the parts according the interval. For lubricating grease type, refer to the LUBRICATING CHART.
- Clean the lubricating grease pressed out after lubricating. Clean the lubricating grease from the parts adhered with sand and dirt.

■ Filter

Filter is very important parts which prevents the impurity in oil and hydraulic oil circuit from getting into the machine. Change the filter regularly. Please contact with HELI dealer or agent.

Filter changing note no matter it is carried out by yourself or HELI dealer or agent:

- Do not use the filter (drum type) again after cleaning.
- When changing the filter, check if there is metal powder adhered on the filter. If there are powder, find out the reason and take proper measures.
- Before assembly, do not open the new filter's package too early .

NOTE

- Only HELI pure filter is to be used.
- Filter with poor quality may affect truck performance and durability. Quality assurance is invalid.

4.4.1.2 Lubricating chart

Oil and grease adding chart (oil and grease adding position and maintenance interval).

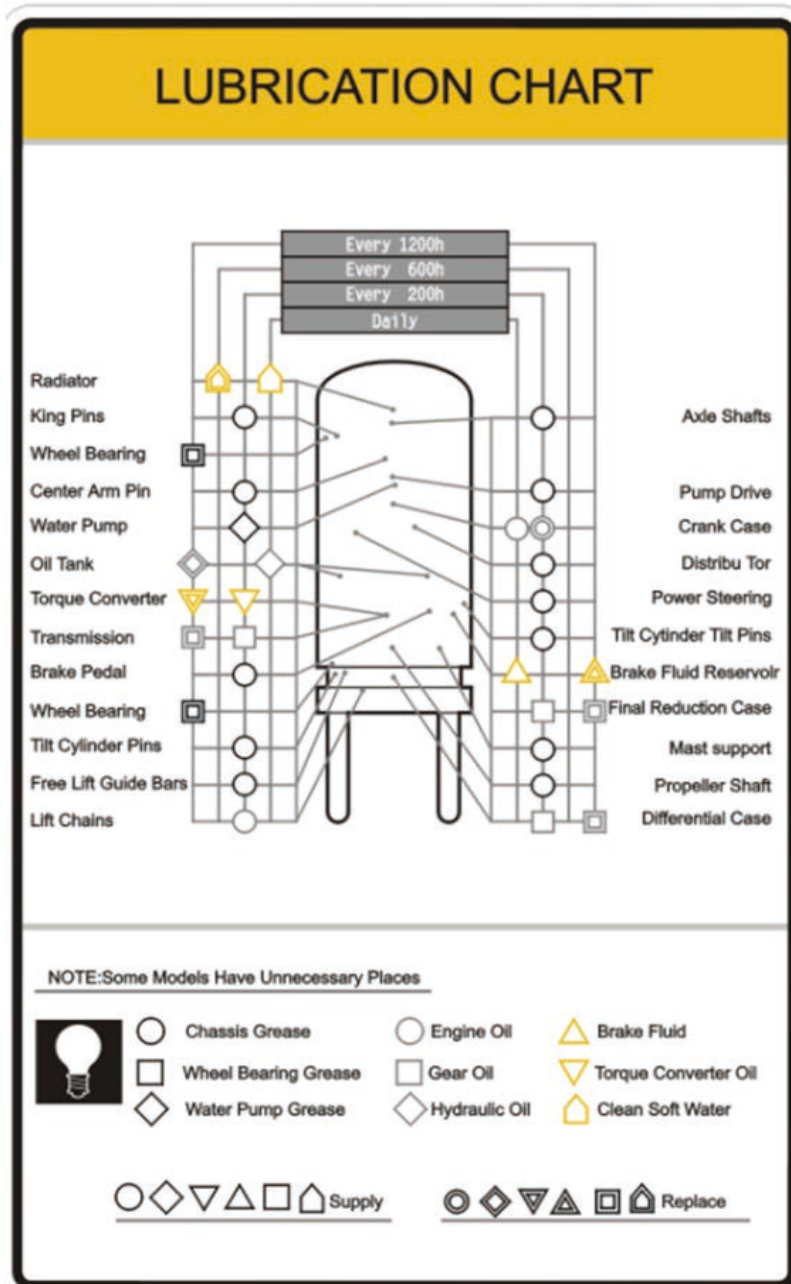

■ Oil type table

Type	Oil number, oil code and applying temperatur				
Diesel (refer to note)	Light diesel number	0#	-10#	-20#	-35#
	Applying temperature (°C)	≥ 4	≥ -5	≥ -5 ~ -14	≥ -14 ~ -29
Engine oil (refer to note)	Viscosity degree	5W/30	10W/30	15W/40	20W/50
	Applying temperature (°C)	-30 ~ +30	-25 ~ +30	-20 ~ +40	-15 ~ +50
Hydraulic oil	HLW-40(Dedicated for HELI)				
	Normal temperature: Mobil DTE 10 Excel 25 Shell Tellus S2 V 46	Low temperature: Mobil DTE Excel 46 Shell Donax TC 10W			
Hydraulic- powered transmission oil	HLT-9(Dedicated for HELI)				
	Normal temperature: Total Dyantrans AC 30 FUCHS RENOLIN ATF-Y 8	Low temperature: Mobil Fluid 424 Shell Donax TD 10W			
Brake liquid	DOT3 compound brake liquid				
Lubricating grease	3# general lithium grease				
Heavy duty tuck gear oil	Viscosity degree	85W/90GL-5		80W/90GL-5	
	Applying temperature (°C)	-15 ~ +49		-25 ~ +49	
Anti-freezing liquid	Code	FD-1	FD-2	FD-2A	FD-3
	Applying temperature(°C)	≥ -25	≥ -35	≥ -45	≥ -50

NOTE: Use the diesel, gasoline and engine oil meeting relative quality standard. Please refer to the engine operation manual for quality standard or consult with HELI dealer/agent.

Oil level table

Parts capacity Model	Hydraulic transmission (torque converter included)	Transmission box		Hydraulic oil tank (basic mast)	Fuel tank	Brake/ clutch liquid reservoir	Radiator	
		mechanical	Hydraulic- powered				Isuzu	Other type
							C240-30	Dachai, jiangling
1-1.8t	6.5	6.6	3.6	30	38	0.4	9	8
2-2.5t		7.6	5.6	40	55			
3t		7.6	5.6	40	60			
3.5t		8.6	6.6	40	60			

IMPORTANT

- Never use the fuel mixed with kerosene because such fuel will facilitate the aging of fuel injection system.
- Use HELI specialized lubricating grease.



Braking system may be badly damaged if improper type brake liquid is used, before using, check the brake liquid type.

4.4.2 Filter element cleaning

CAUTION

- When the engine is working, serious injury may be caused by fan or belt. Shut off the engine before disassemble or clean filter element.
- When cleaning filter element, dust on it may get into eye or be breathed inside. Wear protection glass, dust-proof cover and other protection devices. Clean it where has no people around.

1. Disassemble clamps (three positions) on air cleaner and disassemble the filter element.

2. Knock the filter element gently avoiding damage the sealing surface or clean the element with compressed air (no more than 0.68MPa) carefully from inside to the outside.

3. Check the filter element visually after cleaning. If there is any damage or dirt still, change the filter element.

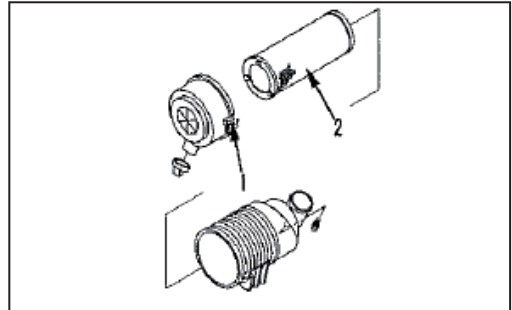

IMPORTANT

Dust may enter into the engine and may be damaged when checking, cleaning or maintaining the filter element with engine running.

Carry out the maintenance work after shutting off the engine.

4.4.3 Water and gas exhausting of the fuel filter (diesel engine)

CAUTION

- Exhaust the water or air until the engine is cooled because the engine is very hot as soon as it stops.
- When exhausting water, fuel will be exhausted out also. Keep it in a tank away from open flame. Clean the running out fuel.

When the oil-water separator alarm indicator flickers, water subsided on the bottom of the filter exceeds the regulated limit. Drain out the water according to the following steps:

1. Loose the exhausting plug at the bottom of the fuel filter. (it is also used as sensor)(1) and drain out the water.

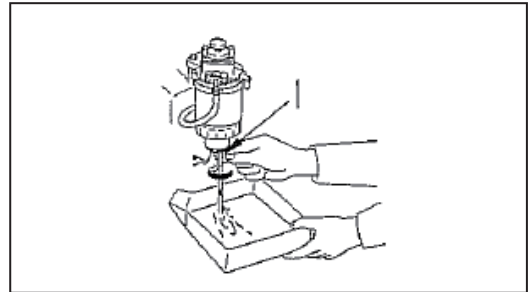

2. Tighten the plug after draining.

3. Air exhausting

Loose the plug A and move the button B upward and downward. Tighten the plug until there is no air bubble.

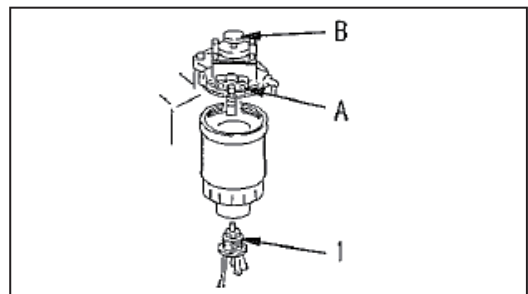

4.4.4 Tyre changing

 CAUTION

- Be care not to be pressed by jack when it slips away. when using jack, ensure the supporting position is firm. Do not crawl under the lifted truck.
- The pressure of the tyre is very high and dangerous.
- Do not disassemble and reassemble the tyre, inner tube and rim or charge the tyre. (These operations need special devices and skills and can only be carried out by trained people.)

1. Unload the goods on truck and park the truck on flat and solid ground. Apply parking brake.

2. Place blocks under the tyres needed to be replaced.

3. Lift the truck at the required position.

- (1) Replace the front tyre: (A) under the outer mast
- (2) Replace the rear tyre: (B) under the counter weight

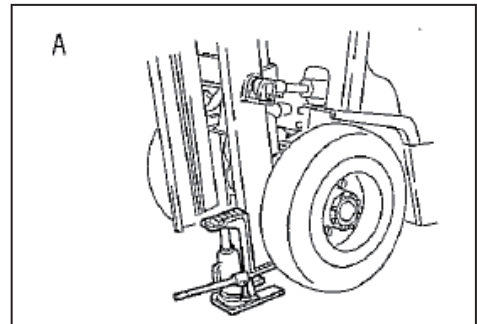

4. Lift the truck to the position where the tyre connects with the ground a little and place a support under the frame. When replacing front tyre, place a support under the forepart and when replacing rear tyre, place one under the rear part.

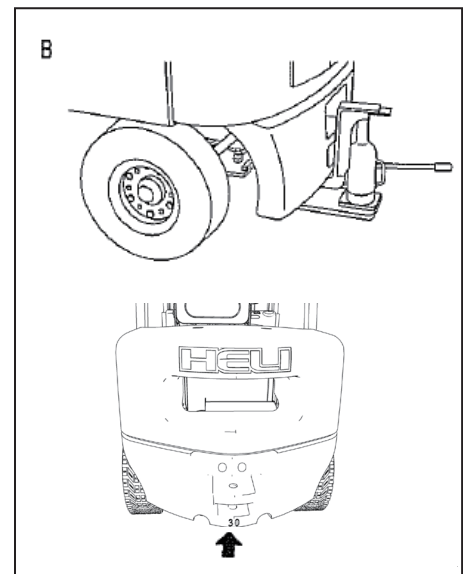

5. Disassembling the tyre

 CAUTION

- Do not loose the rim connecting bolt (special bolt)(2) and nut for the tyre assembled with separated type rim.
- After pressure releasing, loose the hub nut for the tyre assembled with separated type rim.
- For your safety, when changing or inflating the tyre, stay right before the tyre surface as shown in the figure. Never stay on the side of the tyre surface.
- When adjusting pressure with compressor, adjust the pressure of compressor first so as to prevent the inflation pressure exceed the regulated value.
- Deformed or cracked rim is very dangerous. When changing tyre, check carefully not to use fault one.

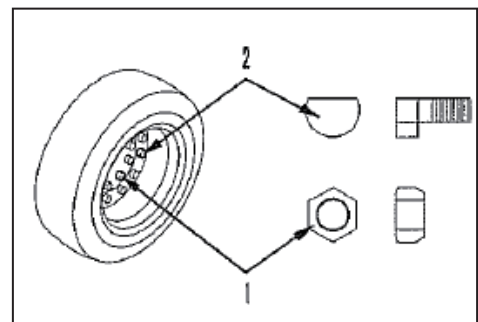

- (1) Loose the hub nut with hub nut wrench or other tools until it can be rotate by hand.
- (2) Lift the truck with jack to the position where the tyre connects with the ground a little. Disassemble the hub nut and tyre.

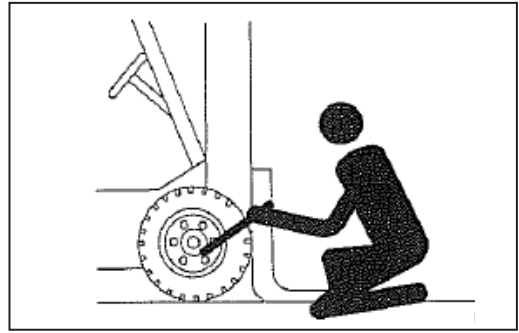

6. Install a new tyre to the hub and rotate the nut one by one. At last tighten the nut diagonally.
7. Move the support from the frame. Lower the jack and tighten the hub nut to regulated torque. For standard torque value, refer to REPAIR PARAMETER.
8. Adjust the inflation pressure to the regulated value. For standard inflation value, refer to REPAIR PARAMETER.
9. After changing, carry out a test run to check if the hub nuts are loose. If necessary, tighten it.

4.4.5 Parking brake shank operation force adjusting



CAUTION

- Wedge the front and rear tyre before adjusting.

1. Press the button (1) and release the parking brake (2) to position B.
2. Adjust the nut (3) until the operation force of the parking brake is reached.

The operation force is 250Nm before delivery. The output brake force may be reduced because of the wear of brake and clearance adjusting mechanism.

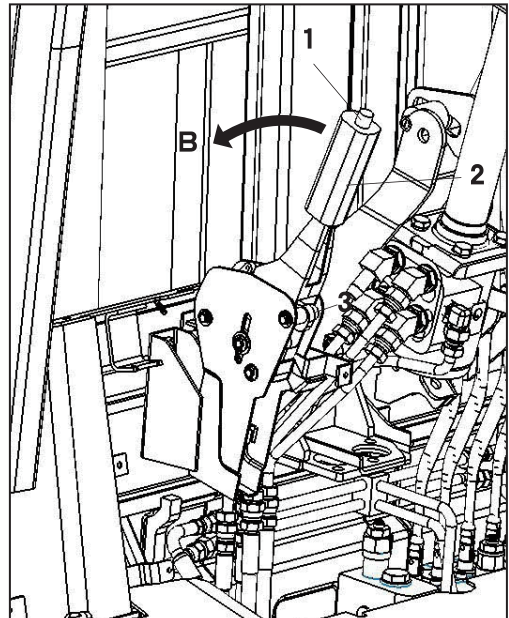

4.4.6 Fuse changing

Fuse may be broken if lights or indicators or the controlling system do not work. Check if the fuses protecting each devices and systems are burn.

⚠ CAUTION

- Before changing the fuse, turn off the power. (turn the starting switch to OFF position)
- Change the fuse with the same standard and capability.
- If the replaced fuse is burn again, it may be caused by the abnormal electric system. please contact with HELI dealer or agent.

■ Diesel engine and gasoline engine

1. Switch the starting key switch to OFF position.
2. Open the engine hood, fuses are in the electric cabinet n the left side of the truck.
3. Disassemble the fuse box cover and puller inside the fuse box.
4. Clamp the fuse with puller and remove it. Check if it is broken visually.
5. If fuse is broken, change it with the same standard and capability.

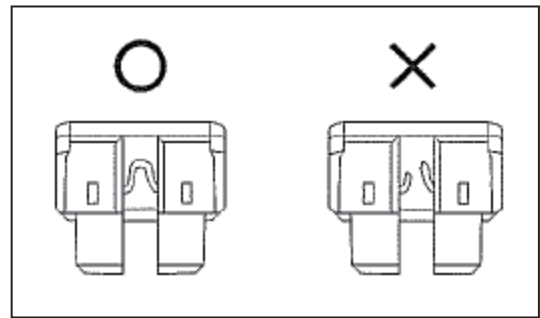

■ Electric cabinet

Refer to the following table for fuse capability and corresponding electric parts.

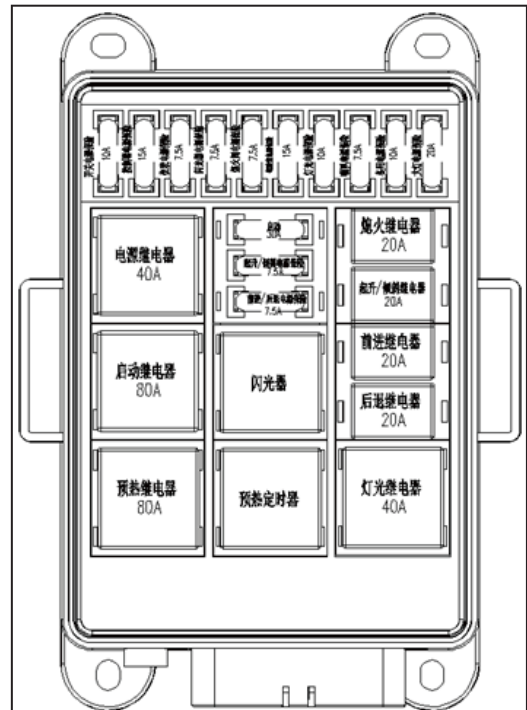

Number	Capability	Color	Corresponding electric parts	Note
1	7.5A	Brown	Meter	
2	7.5A	Brown	Steering light	
3	7.5A	Brown	Horn	
4	7.5A	Brown	Shutting off valve	
5	7.5A	Brown	Commutator	For hydraulic powered truck
6	7.5A	Brown	Lifting valve	For OPS
7	10A	Red	Width lamp, brake lamp	
8	10A	Red	Reversing light	
9	10A	Red	Spare	
10	15A	Blue	Cab power	
11	15A	Blue	Controller	For OPS
12	20A	Yellow	Front lamp	
13	30A	Green	Starting	

Refer to the following table for relay capability and corresponding electric parts.

Number	Capability	Corresponding electric parts	Note
1	40A	Power relay	
2	40A	Light relay	
3	80A	Preheating relay	
4	80A	Starting relay	
5	20A	Forward relay	For hydraulic powered truck
6	20A	Backward relay	For hydraulic powered truck
7	20A	Lifting /tilting relay	For OPS
8		Flasher	
9		Timer	

Controller (for hydraulic powered truck)
The controller has OPS function.

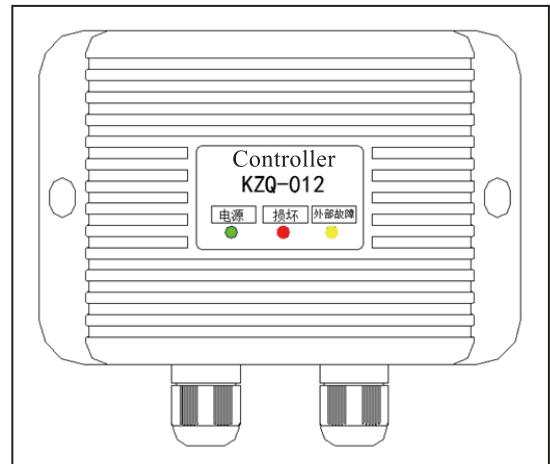

- OPS (driving function)

If the condition that the seat switch is open or driver goes away from the seat or sits on the seat with improper posture is detected by controller for 5s, the controller will disconnect the power of transmission commutator and thus driving power will be disconnected. The locking condition will be released when seat switch is closed and direction switch is placed on neutral position.

- OPS (Loading function)

If the condition that the seat switch is open or driver goes away from the seat or sits on the seat with improper posture is detected by controller for 5s, the controller will disconnect the power of solenoid valve of the control valve and thus lifting and lowering operation will be locked.

- Alarm function

If the condition that the seat switch is open is detected by the controller for 1s, meter buzzer will alarm and the alarm indicator will light on. if the direction switch is not returned to neutral position and the seat switch is open, the buzzer will alarm continually to remind the operator that the OPS is on starting condition.

3 indicators are fixed on the controller so as to know the working condition of the controller. They are power indicator, outer fault indicator and controller fault indicator. If the green power indicator lights on, it means the controller has electricity; if the yellow outer fault lights on, it means the external of the controller has fault; if the red controller fault indicator lights on, it means the controller itself has fault and has to be changed.

4.4.7 Bulbs changing

If the bulb does not light on, the bulb itself may be broken except the fault of fuse. Change the bulb after checking if the fuse is broken.

CAUTION

- Change the bulb with the same standard.
- If the bulb still does not light on, it may be caused by the abnormal system. Please contact with HELI dealer or agent.

1. Switch the starting key and light switch to the OFF position.
2. Remove the glass cover and change the bulb.

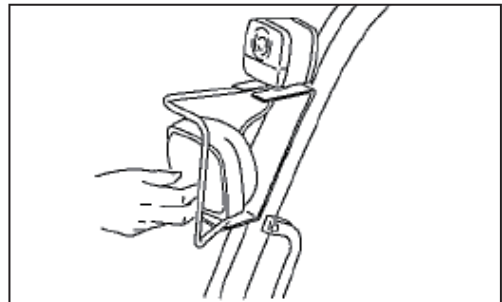

Light power
Front lamp:55W(12V)

4.5 Steps of dealing with the fault battery

If a battery has fault, start the truck with jumper cable to use other truck's battery.

■ Notes when disconnecting and connecting jumper cable

⚠ CAUTION

- Never connect the positive(+) and negative (-) terminal when connecting the jumper cable.
- Wear safety glass and rubber glove when starting engine with jumper cable.
- Take care not to let the fault truck contact with the normal one when starting the engine with other truck. Hydrogen which is flammable is produced by battery is easy to be lighted by small spark around battery.
- Turn the starting key switch on two trucks to OFF position when connecting jumper cable or truck may move suddenly after the power is connected.
- Connect the jumper cable correctly. Connect the positive cable first when connecting while disconnecting, disconnect the negative cable first. When connecting, connect the last cable to the engine block of the fault truck which produces spark. Keep the connecting point away from the battery.
- When disconnecting cable, never make the clamp connect with the other clamp or the truck.
- The two truck must have the same voltage.

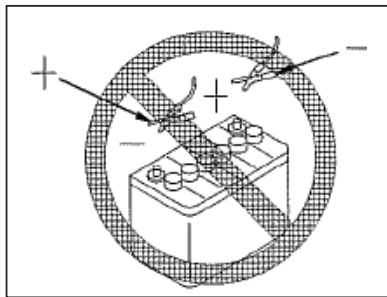

■ Jumper cable connecting

Turn the starting key switch on both truck to OFF position and place the forward/backward lever on neutral position. Check if the parking brake is applied. Connect the cables referring to the figure.

- (1) Connect the clamp of jumper cable A to the positive terminal of the fault truck;
- (2) Connect the other clamp of jumper cable A to the positive terminal of the normal truck;
- (3) Connect the clamp of jumper cable B to the negative terminal of the normal truck;
- (4) Connect the other clamp of jumper cable B to the engine block of the fault truck.

IMPORTANT

- Use proper connecting jumper cable and clamp with proper size according to the battery size.
- Two trucks must have batteries with same capacity.
- Make sure the clamps and cables are not damaged or corroded.
- Connect the clamps to terminals or blocks correctly and firmly.

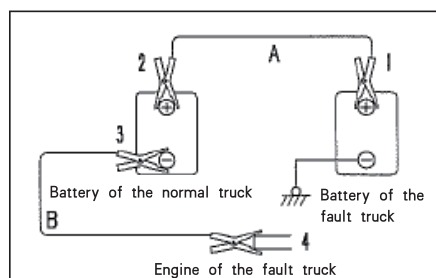

■ Engine starting



Check if the forward/backward operation levers of two trucks are placed on neutral position and if parking brakes are applied.

1. Make sure clamps are connected to battery terminal firmly.
 2. Start the normal truck's engine and make it run at highest speed.
 3. Turn the starting key switch on the fault truck to the STARTING position to start the engine.
- If the engine is not started, start it again 2 minutes later or after a longer time.

■ Cable disconnecting

After the engine is started, disconnect the cable according to the opposite order.

1. Disconnect the other clamp of jumper cable B from the engine block of the fault truck.
2. Disconnect the clamp of jumper cable B from the negative terminal of the normal truck;
3. Disconnect the other clamp of jumper cable A from the positive terminal of the normal truck;
4. Disconnect the clamp of jumper cable A from the positive terminal of the fault truck;

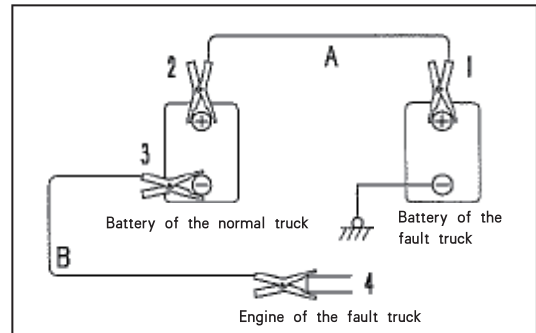

4.6 Working in cold weather

■ Notes when the temperature is low

It is hard to start the engine when the temperature is low. What is more, the coolant may be frozen. Do as the following:

■ Fuel, lubricating oil and hydraulic oil

Use fuel, lubricating oil and hydraulic oil with low viscosity.

For regulated viscosity, refer to OIL TYPE TABLE.

■ Coolant



CAUTION

- Coolant is poison and take care not to get in touch with your skin. If so, wash with lots of clean water and see a doctor.
- Contact professional company or HELI dealer or agent to deal with the drained coolant. Never pour it onto ground or drainage ditch because it is poison.

IMPORTANT

Use HELI specified coolant.

When delivery, coolant suits for the -35°C environment temperature is filled.

Notes when adding or changing coolant:

- Check if radiator, water pump and pipes leak.
- Drain out the coolant and clean the interior of the system before adding coolant.

■ Battery



CAUTION

- Battery will produce flammable gas and keep it away from open flame.
- Electrolyte is poison and take care not to get in touch with your skin. If so, wash with lots of clean water and see a doctor.
- Never pour electrolyte onto ground or drainage ditch because it is poison.
- If electrolyte gets in touch with the truck, clean it with clean water.
- If battery freezes, do not charge it or start the engine with other power, or the battery may explode.
- Battery performance will be badly affected under low temperature environment and thus engine will be hard to start. Battery with insufficient charging will freeze. So charge the battery fully for next day's start.
- Battery performance will be badly affected under low temperature environment so disassemble it from the truck to keep it in a warm place and assemble it the next day. (Especially when the temperature is low or the truck will not use for a long time.)

■ Note after working

Drain out the water in fuel pipeline in preventing of freezing.

Please refer to the WATER AND GAS EXHAUSTING OF THE WATER-OIL SEPERATOR for oil-water separator water draining of the diesel engine.

■ When the cold weather is over

Do the following as the weather gets warm.

- According to the OIL TYPE TABLE, change the fuel and engine oil to regulated viscosity.

4.7 Measures for engine over heating

■ Measures for engine overheating



CAUTION

There is a danger of scalding caused by the ejecting of steam or boiling water if the radiator cap is removed at once. Remove the radiator cap slowly after the cooling liquid is cool.

Take the following measures when the coolant temperature gauge points to the red range:

1. Park the truck in a safe area.
2. Keep the engine idling and open the engine hood for good ventilation.
Shut off the engine at once if cooling fan does not work.
3. Shut off the engine when the coolant temperature gauge points to the white range:
4. Check the following items when the engine is cool:
 - coolant level
 - check if fan belt is cut or loose;
 - engine oil level
 - check if the radiator is blocked;
5. If the coolant or engine oil level is low, add to proper level.

If the fault reasons, contact with manager and stop use the truck. And then contact with HELI dealer or agent.

■ Clean the interior of the cooling system

If waterlogging or rust is produced in the cooling system, it means the cooling system efficient is poor and it causes overheat.

Please contact with HELI dealer or agent for maintenance because the cooling system needs periodical check and cleaning with radiator washing solution.

■ Cleaning of the radiator



CAUTION

- Wear glasses in preventing of foreign matters getting into eye.
- Never make the compressed air, steam or water flow point to people or serious injury may be caused.

Engine overheat may be caused if radiator is blocked, clean it with gas flow, steam or water flow. Set the gas flow or steam to the regulated pressure and adjust the nozzle to proper angle:

Gas pressure: lower than 0.98MPa (10kg/cm²)

Water pressure: lower than 0.49MPa (5kg/cm²)

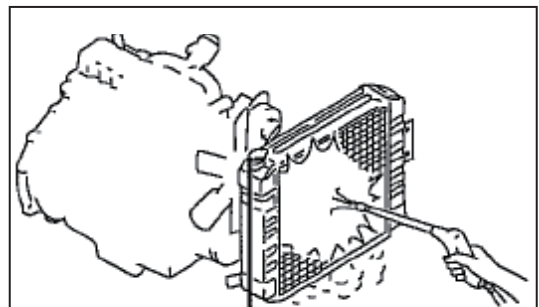

■ Check the fan belt tension

If the belt is loose, adjust it to regulated tension.

For belt tension adjusting, please contact with HELI dealer or agent.

4.8 Operate truck in special environment or with force

The truck is designed and tested for normal working condition and environment. If it is used under special environment and condition, truck will be badly affected such as aging, life time reducing, parts harm even maintenance free parts.

If the truck has to be operated under special environment, the truck needs special maintenance and measures to bear the harsh working condition or environment. For detail, please contact with HELI dealer or agent.

■ Examples when using the truck in special environment or with force

- Truck travel on road with saline water, chemicals (acidity or alkalinity) or solution directly or contact with such environment indirectly through driver's hand or feet;
- Environment full with erosive gas;
- Blow by salty sea wind;
- Environment with dew or often soaked by water.
- Dusty environment;
- Other applications other than the design purpose;
- Specialized or special working for a long time;
- Applications prohibited in this manual;
- Others.

IMPORTANT

- HELI will not bear the responsibility if the truck is used under the special environment or with force.
- Technology may not involve in certain condition.
- The truck can not be used where has a danger of explosive.

4.9 Measures if the fork can not be lowered

CAUTION

- Stop working at once if the fork can not be lowered during operation. Never use the truck before repair.
- Place signs such as NO ENTERING or NO USING on the truck in preventing of people going under the lifted fork.
- Do not touch mast, fork, chain or other working devices or truck may move accidentally and serious accident may be caused.
- Contact with HELI dealer or agent for repairing.

1. Stop working at once if the fork can not be lowered during operation.
2. Park the fault on a flat ground away from the emergency exit and fire extinguisher. For parking, refer to STOPPING AND PARKING and STOPPING AND PARKING FOR A TIME.
3. If the loaded fork can not be lowered during operation, check if there is a danger of goods falling. Make sure there is a wide area marking NO ENTERING or park the truck facing the wall.

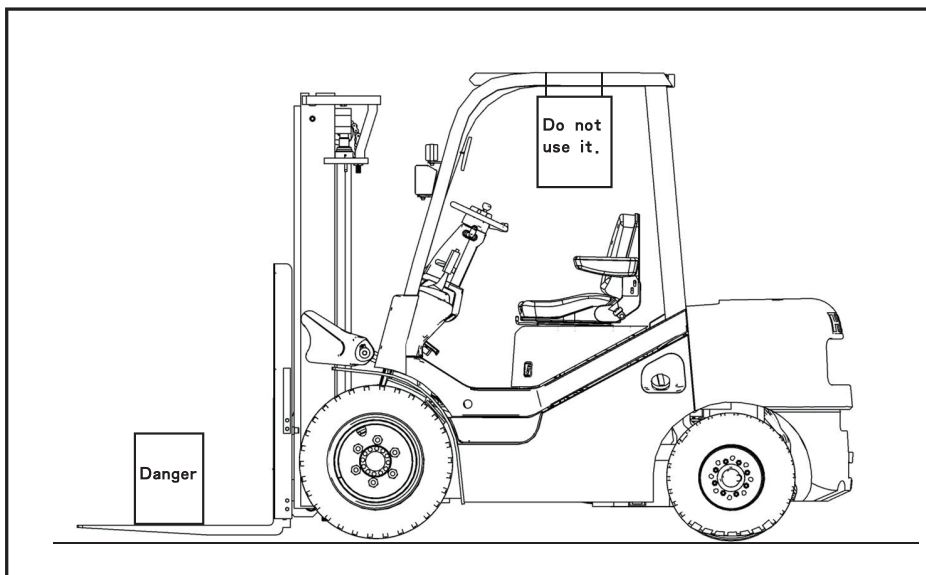

4.10 Truck cleaning

CAUTION

There is a danger of truck being out of work or mis-moving if water entering into electric system (controller, sensor, contactor and so on). Do not clean the electric system with water or air with high pressure.

Cleaning steps

1. Turn the starting key switch to the OFF position and draw out the key.
2. Clean the parts (1~4) shown in the figure and follow the notes described in the table.
3. Dry the cleaning parts.
4. Insert the key and turn it to ON position after the cleaning parts are dry completely. Check if there is any abnormal and then begin to operate.

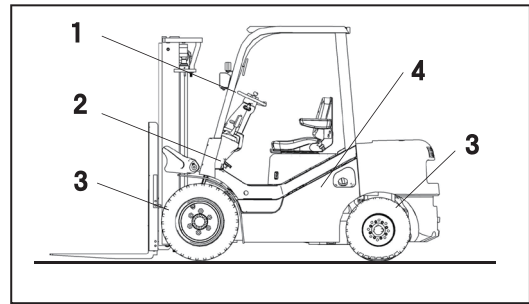

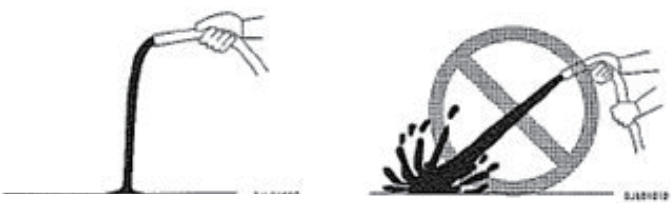
No.	Cleaning parts	Cleaning method
1	Cabinet surface	Clean it with water from pipeline NOTE: when cleaning, reduce the water flow so as to reduce the water pressure as shown in the figure below. (for part 1 and part 2)
2	Front floor board	
3	Front and rear tyres Front and rear axle	Clean with air or water with high pressure from pipeline
4	External parts except the parts above	Clean with air or water with high pressure from pipeline
Other notes		<ol style="list-style-type: none"> 1. Do not clean the interior of the meter; 2. Cover the engine, transmission box and their electric devices such as electric wire, contactor and fuses and so on with water proof cloth when cleaning engine hood and parts under the floor board with high pressure air and water.

4.11 Storing for a long time

Stick to the following points when storing the truck for long time (more than one month).

■ Before storing

Before storing the truck, carry out the following maintenance after cleaning the parts. If the truck has to be kept outside, park the truck on a flat ground and cover it with canvas.

- Add the fuel tank fully so as to prevent water from depositing.
- Apply lubricating grease and change the engine oil.
- Apply lubricating grease to the exposed part of the hydraulic cylinder piston rod.
- Disconnect the battery negative terminal and cover it or disassemble it from the truck and store it inside.
- Use HELI specified coolant avoid freezing.

■ During Storing



CAUTION

If anti-rust operation has to be done inside, open the window for ventilating and take measures from gas poisoning.

- Operate or drive the truck once a month so as to ensure the lubricating parts are protect by oil film completely during storing.
- Clean the lubricating grease on hydraulic piston rod when operating working devices.
- Charge the battery once a month because the battery will discharge even it does not work.

■ After storing

Carry out the following maintenance before operation after storing.

- Clean the lubricating grease on hydraulic piston rod.
- Apply lubricating grease and engine oil where necessary.
- Check the engine oil before and after engine starting. If the engine oil is mixed with moisture, change the engine oil.

IMPORTANT

Please contact with HELI dealer or agent before operation when using the truck without anti-rust maintenance once a month.

4.12 slinging the truck



CAUTION

- Put the sling into the specified holes on top of the overhead guard and counter weight.
- Never sling the truck at the over head guard and cab base (if cab is assembled), or there is a danger of falling down.
- Put the sling into the specified holes on top of the overhead guard and counter weight after ensuring the mast and counter weight are assembled firmly.
- Any person is not allowed to stay under or near the truck.

1. The slinging positions are the top part of the over head guard and the holes of the counter weight.

2. Check if the mast and counter weight are assembled firmly.

Tighten the counter weight bolts to regulated torque.

Tighten the mast lower part fixing bolts to regulated torque.

Please refer to 4.16 REPAIR PARAMETER for torque value.

3. Use undamaged sling and steel rope with enough strength.

4. When slinging the truck, be care not to let the over head guard or cab contact with steel rope and so on. Adjust the steel rope to proper length so as to avoid truck tilting. Do not hit the truck when slinging.

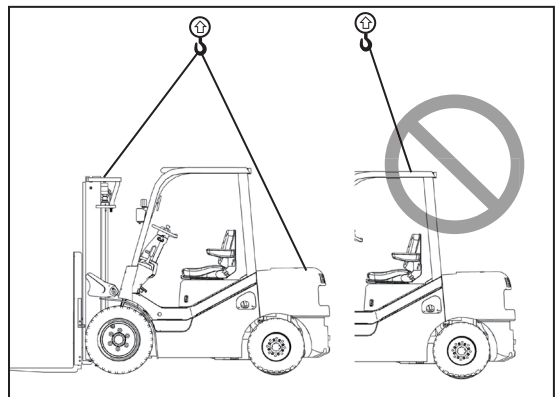

4.13 Loading and unloading the truck



CAUTION

There is a danger of tipping over and falling when loading or unloading the forklift truck. So follow the rules below:

- Park the trailer on a flat road. Apply parking brake and wedge the wheels.
- Use connection board with proper length, width and strength.
- Operate the truck with proper posture.
- If the truck is operated with such posture (the seat does not bear your whole weight, for example stand or lean against forward, backward or side when operating), the OPS will act and engine power transmission will be cut. In that case, the truck will slide down even acceleration pedal is pressed or the truck is going uphill. If necessary, assign a towerman, so that the driver is not necessary to stand or lean forward or side to observe around. Please refer to the OPS (driving function) for detail.
- Place the board to form a gentle slope when using it. Align the center of the forklift truck and trailer's and lock firmly avoiding displacement.
- Do not change the direction when travelling on a board. If necessary, place the board again according to the needed direction and travel again.

1. Use a trailer with enough capacity according to forklift truck weight and size.
2. Park the trailer on a flat ground. Apply the parking brake and wedge the wheels.
3. Connect the loading platform and ground with connection board and make sure it will not disconnect.
4. Do not move the trailer before loading is finished.
5. Operate the truck slowly with proper posture when loading or unloading the truck.
6. Wedge the wheels of the truck and fix the truck with steel rope or chain in order to prevent the truck from moving during transportation.

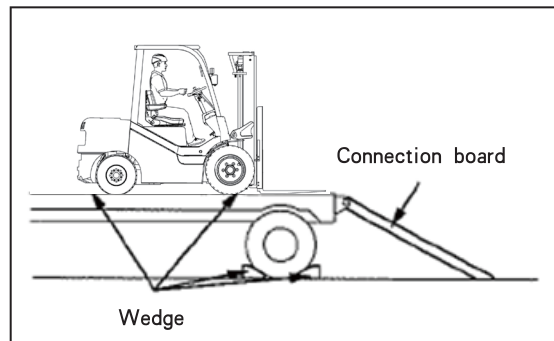

4.14 Check and maintenance time table

- Please contact HELI dealer or agent for check and maintenance items not described in the manual.
- Serious accident may be caused or truck service life may be affected if the truck is not checked or maintained improperly. For safety reason, please contact HELI dealer or agent for check, maintenance and repair.
- The service period of engine oil and engine oil cartridge can also be decided according to Engine Manual.

■ Check and maintenance time table

Check and maintain the truck as recommended by HELI.

Table 1-9 are HELI internal combustion forklift truck maintenance time table based on standard working time and condition (8 hours for one day, 200 hours for one month). If the truck works under harsh condition, maintain ahead of schedule. ○ refers to check, maintain and replenish. ● refers to change. Please refer to gasoline truck maintenance for LPG truck maintaining.

Table 4-1 Engine maintenance time table

Item	Checks	Tool	Check and maintenance interval				
			Daily (8 hrs)	Monthly (200hrs)	Quarterly (600hrs)	Semiannually (1200hrs)	Annually (2400hrs)
Engine	Engine working condition by visual check		○				
	Engine sound		○				
	Exhausting gas color		○				
	Clean or change filter element			○	●		
	Cleanness of crankcase				○		
	Clearance of adjusting valve	Thick plug gauge				○	
	Tighten cylinder head bolt	Torque wrench		○ (gasoline engine, only the first time)			○ (only diesel engine)
	Cylinder compression pressure	Pressure gauge					○
Crankshaft ventilation	Check if valve and pipeline are blocked or damaged.				○		
Speed controller or injection pump	Check the max. rotation speed without load	Speedometer				○	
Lubricating system	If engine leaks		○				
	Check the oil level and cleanness		○				
	Change engine oil			● 50hrs for the first time, every 200hrs in the future			
	Change engine oil filter element			● 50hrs for the first time, every 200hrs in the future			

Item	Checks	Tool	Check and maintenance interval				
			Daily (8 hrs)	Monthly (200hrs)	Quarterly (600hrs)	Semiannually (1200hrs)	Annually (2400hrs)
Lubricating system	Change engine oil (GCT gasoline engine)				● (every 500h or 3 months, whichever comes first)		
	Change engine oil filter cartridge (GCT gasoline engine)				● (every 500h or 3 months, whichever comes first)		
	Change engine oil (PSI gasoline engine)				● (every 500h or 3 months, whichever comes first)		
	Change engine oil filter cartridge (PSI gasoline engine)				● (every 500h or 3 months, whichever comes first)		
Fuel system	Visually check for fuel leak from pipe, pump or tank.		○				
	Check if fuel filter is blocked				○		
	Clean the fuel filter (gasoline engine)				○		●
	Change the fuel filter (diesel engine)				●		
	Check the nozzle; adjusting pressure, condition (diesel engine)					○	
	Check if the vaporizer connecting mechanism is loose and its cleanness (gasoline engine).				○		
	Ignition time (gasoline engine)	Timer			○		
	Injecting time(diesel engine)						○
	Water exhausting of the fuel tank				○		
	Clean the fuel tank					○	
	Check the fuel level		○				
Cooling system	Coolant level		○				
	Leakage condition		○				
	Pipeline ageing condition				○		
	Performance and mounting condition of the radiator cap		○				
	Clean or change the coolant				●		
	Check the tension of fan belt and condition		○				

Table 4-2 Transmission system maintenance time table

Item	Checks	Tool	Check and maintenance interval				
			Daily (8 hrs)	Monthly (200hrs)	Quarterly (600hrs)	Semiannually (1200hrs)	Annually (2400hrs)
Clutch	Check the spare travel of the clutch and the distance between the pedal and the floor when it is released.	ruler	○				
	Sound and operation condition		○				
	Slide and engage condition		○				
Mechanical transmission box	Gear shifting lever operation condition and check if it is loose.			○			
	Leakage condition		○				
	Change the oil			○	●		
Hydraulic-powered transmission box	Leakage condition		○				
	Check the oil level or change the oil			○			●
	Gear shifting lever operation condition and check if it is loose.			○			
	Performance of controlling valve and hydraulic-powered clutch		○				
	Inching valve performance		○				
	Spare travel of inching pedal and its working condition		○				
	Change filter element					●	
Front axle	Leakage check		○				
	Change the oil					●	
	Check if the fixing bolts are loose.			○			

Table 4-3 Wheel maintenance time table

Item	Checks	Tool	Check and maintenance interval				
			Daily (8 hrs)	Monthly (200hrs)	Quarterly (600hrs)	Semiannually (1200hrs)	Annually (2400hrs)
Tyre	Inflation pressure	Pressure gauge	○				
	Crack or damage		○				
	Wear condition	Depth meter		○			
	Abnormal wear condition		○				
	Check if there are any foreign matters on the tyre such as nail.			○			
Tyre mounting	Check if the bolts are loose.	Test hammer	○				
	Check if there is any damage.		○				
Rim and spoke	Check if the rim, spoke and plate wheel have any damage.		○				
Wheel bearing	Check if there is any loose and noise.			○			
	Clean and apply the lubricating grease again.					●	
Axle	Check if the axle body is deformed, has any crack or damages.			○			

Table 4-4 Steering system maintenance time table

Item	Checks	Tool	Check and maintenance interval				
			Daily (8 hrs)	Monthly (200hrs)	Quarterly (600hrs)	Semiannually (1200hrs)	Annually (2400hrs)
Steering wheel	Clearance check		○				
	Check if there is any loose in axial direction.		○				
	Check if there is any loose in radial direction.		○				
	Check the operation condition.		○				
Steering unit	Check if the fixing bolt is loose.			○			
Knuckle of the rear axle	Check if the king pin is loose or damaged.	Test hammer		○			
	Check if there is any curve, deformation, crack or damage condition.			○			
	Check the mounting condition.			○			
Steering cylinder	Check the operation condition.		○				
	Check if there is any leakage.		○				
	Check if there is any loose when mounting and Hinged.			○			

Table 4-5 Braking system maintenance time table

Item	Checks	Tool	Check and maintenance interval				
			Daily (8 hrs)	Monthly (200hrs)	Quarterly (600hrs)	Semiannually (1200hrs)	Annually (2400hrs)
Brake pedal	Spare travel		○				
	Pedal travel		○				
	Operation condition		○				
Parking brake operation	Check if brake works well and has enough travel.		○				
	Operating performance		○				
Rod, cable and so on	Operating performance			○			
	Check if the connection is loose.			○			
Pipeline	Check if there is any damage, leakage or crack.			○			
	Check the condition of connection and clamp parts.			○			
	Check if there is air in the brake pipeline.		○				
Master cylinder and wheel cylinder	Leakage condition		○				
	Check the oil level and change it when necessary.			○		●	
	Working condition of master pump and wheel cylinder						○
	Check master cylinder and wheel cylinder for leakage or damage.						○
	Check the wear condition of the master pump, piston cup, one-way valve. Change if necessary.						●
Brake drum and brake shoe	Check drum mounting parts for looseness.	Test hammer		○			
	Wear condition of friction plate	vernier caliper					○
	Working condition of brake shoe						○
	Check anchor pin for rust.						○
	Check return spring for damage.	Ruler					○
	Check if the clearance of automatic adjusting device in working is proper.						○
	Check brake drum for wear and damage.						○
Brake floor board	Check if the floor board deforms.						○
	Check if it is crack.	Penetrant test					○
	Check if it is loose when mounting.	Test hammer					○

Table 4-6 Lifting system maintenance time table

Item	Checks	Tool	Check and maintenance interval				
			Daily (8 hrs)	Monthly (200hrs)	Quarterly (600hrs)	Semiannually (1200hrs)	Annually (2400hrs)
Fork	Check forks for damage, deformation and wear condition.		○				
	Check for stopper pin for damage or wear.				○		
	Check fork base and hook welding for defective cracks or damage.			○			
Mast and fork bracket	Check if the welding between the inner mast, outer mast and cross beam has crack and damage.			○			
	Check tilt cylinder bracket and mast for defective weld, cracks or damage.			○			
	Check inner and outer mast for defective weld, cracks or damage.			○			
	Check fork bracket for defective weld, cracks or damage.			○			
	Check roller for looseness			○			
	Check mast support bushings for wear or damage.						○
	Check mast support cap bolts for looseness.	Test hammer		○ (only the first time)		○	
	Check lift cylinder tai bolts, piston rod head bolts, U-bolts and piston head guide bolts for looseness.	Test hammer		○ (only the first time)		○	
	Check roller, roller axle and welded parts for cracks or damage.			○			
	Chain and sheave	Check chains for tension, deformation, damage or rust.		○			
Chain lubricating				○			
Check connection of chain anchor pin and chain for looseness.				○			
Check sheaves for deformation or damage.				○			
Check sheave bearing for looseness.				○			
Attachments	Check working condition of attachments			○			
Lifting cylinder	Check piston rod, rod screw and rod end for looseness, deformation or damage.	Test hammer	○				
	Operating condition		○				
	Leakage condition		○				
	Check pins and bearings for wear or damage.			○			
Hydraulic pump	Check hydraulic pump for leaks or noise.		○				
	Check pump drive gear for wear.			○			

Table 4-7 Hydraulic system maintenance time table

Item	Checks	Tool	Check and maintenance interval				
			Daily (8 hrs)	Monthly (200hrs)	Quarterly (600hrs)	Semiannually (1200hrs)	Annually (2400hrs)
Hydraulic oil tank	Oil level check and oil change		○				● 1500hrs for the first time, every 2400hrs in the future
	Clean oil suction filter element					○	
	Remove the foreign matter					○	
Return oil filter	Change the return oil filter				● 300hrs for the first time, every 600hrs in the future		
Control lever	Check if the connection is loose		○				
	Operating condition		○				
Control valve	Oil leakage		○				
	Working condition of safety valve and tilting self lock valve			○			
	Safety valve pressure measurement	Oil pressure gauge				○	
Pipeline connectors	Check for oil leakage, looseness, crack, deformation and damage.		○				
	Pipeline change						● 1-2 years
Gasket for hydraulic oil tank cover and fuel tank cover	Change (without disassemble)						2 years
	Change (with disassemble)						Disassemble and change

Table 4-8 Electric system maintenance time table

Item	Checks	Tool	Check and maintenance interval				
			Daily (8 hrs)	Monthly (200hrs)	Quarterly (600hrs)	Semiannually (1200hrs)	Annually (2400hrs)
Ignition device (for gasoline engine)	Check distributor cap for check.				○		
	Check spark plug for burn.						○
	Adjust spark plug clearance				○		
	Clean spark plug				○		
	Check distributor cap high-voltage cord for installation						○
	Check distributor cap for burn						○
	Check distributor center piece for wear or damage						○
	Apply grease on spindle				○		
	Check high voltage wire for damage						○
Starting motor	Engagement of small gears				○		
Battery	Electrolyte level, cleaning			○			
	Proportion of electrolyte				○		
Wire	Wire harness damage and loose condition			○			
	Electric circuit connection condition			○			
Generator	Generator connection condition			○			
	Generator belt loose or damage condition				○		
	Generator electricity generating condition						○
Electric box	Check plug and connector condition			○			
	Check the box and plug and connector anti-water function.			○			

Table 4-9 Safety devices and accessories maintenance time table

Item	Checks	Tool	Check and maintenance interval				
			Daily (8 hrs)	Monthly (200hrs)	Quarterly (600hrs)	Semiannually (1200hrs)	Annually (2400hrs)
Overhead guard and backrest	Check if the mounting is firm	Test hammer	○				
	Check if there is deformation, crack and damage		○				
Steering indicator	Working and mounting condition		○				
Horn	Working and mounting condition		○				
Light	Working and mounting condition		○				
Buck buzzer	Working and mounting condition		○				
Rear view mirror	Check if there is dirt or damage		○				
	Rear view condition		○				
Meter	Meter working condition		○				
Seat	Check if the bolts are damaged or loose			○			
Body	Check if the frame and cross beam are damaged or cracked.				○		
	Check rivet or bolts are loosed.	Test hammer			○		
	If necessary, check the parts that repaired before.		○				
	Overall check						○
Grease adding and oil change	Check the chassis's lubricating condition after cleaning	Grease gun		○			

4.15 Change the safety key parts regularly

Safety parts listed in the table below should be changed regularly for safety reason.

If the parts exceed their service life, they may be aging and go bad. Their condition is hard to be known through regular maintenance. So no matter how are the parts, change them if their service life is reached. If there is any abnormal before its service life is reached, repair or replace the part at once. If the pipe clamp has any damage such as deformation or crack, change the pipeline along with the clamp.

■ Key parts table

Number	Parts name	Service life
1	Main cylinder, wheel cylinder cup, dust sealing and so on	1
2	Rubber parts of brake booster	1
3	Brake pipeline	2
4	Oil reservoir and pipeline	2
5	Parking brake switch (hydraulic type)	2
6	Fuel pipeline	2
7	Rubber parts inside of the steering system	2
8	Lifting chain	2-4
9	Hydraulic pipeline	2

4.16 Repair parameter (gasoline engine)

Parts		Checks	Unit	1-1.8t	2-2.5t	3-3.5t		
Driving system	Tyre	Tyre inflation pressure	Front tyre	kPa	790	860	970	
			Rear tyre	kPa	1000	860	790	
	Hub nut	Tighten torque	Front tyre	Nm	150-175	480-560	480-560	
			Rear tyre	Nm	130-194	130-194	130-194	
Steering system & braking system	Steering hand wheel		Clearance (when pump is working)		mm	10-15°	10-15°	10-15°
	Mechanical type	Clutch pedal	Clearance		mm	/	25	25
			The initial height of the front floor board		mm	/	125	125
		Brake pedal	Clearance		mm	/	20	20
			The initial height of the front floor board		mm	/	125	125
	Hydraulic-powered type	Inching pedal	Clearance		mm	1-2	1-2	1-2
			Inching travel		mm	20	20	20
			The initial height of the front floor board		mm	115	115	115
		Brake pedal	Clearance		mm	20	20	20
			The initial height of the front floor board		mm	115	115	115
			Operation force of the parking brake		N	250	250	250
Overhead guard	Leg fixing bolt	Tighten torque		Nm	90	90	90	
	Top connecting bolt	Tighten torque		Nm	90	90	90	
Counter weight		Tighten torque		Nm	500	500	560	
Front axle fixing bolt		Tighten torque		Nm	130-194	201-301	201-301	

Optional

Optional item	Optional details
Transmission model	Mechanical transmission
	Hydraulic-powered transmission
Mast type	Normal
	Full free 2-stage mast
	Full free 3-stage mast
Direction changing way	Mechanical direction changing
	Electro-hydraulic direction changing
Tyre choice	Single pneumatic tyre (front/rear wheel tyre)
	Single normal solid tyre (front/rear tyre)
	Single solid tyre without trace (front/rear wheel tyre)
	Dual pneumatic tyre(front wheel tyre), single pneumatic tyre (rear wheel tyre)
Tilting angle	6° – 12°
	6° – 6°
	3° – 6°
	6° – 10°
	5° – 10°
	3° – 3°

Optional item	Optional details
Number of throw	Two throw
	Three throw
	Four throw
	Five throw
Overload choice	Overload protection (the third throw)
Muffler type	Combined type resistance muffler
	Fire extinguishing muffler
	Purification muffler
Exhausting way	Standard air exhausting
	High air exhausting
	Middle air exhausting
Air cleaner	Normal air cleaner
	Dry type double air cleaner
	Wet type double air cleaner
Thread	Metric thread
	American thread
Brake way	Manual brake
Sound insulation and noise reduction choice	Sound insulation and noise reduction device
Speed limit choice	Speed limit alarm
Warning light choice	Rotating type warning light
	flickering type warning light
	Rotating buzzer warning light
Seat choice	Normal seat
	Grammer semi-suspension seat (with safety switch)
	Grammer semi-suspension seat (without safety switch)
	Gaoyou suspension seat(with safety switch)
	Gaoyou suspension seat(without safety switch)
	Tiancheng semi-suspension seat (with safety switch)
	Tiancheng semi-suspension seat (without safety switch)
Tiancheng semi-suspension seat (with safety switch)	
Cab	Panel-mounted cab

Optional item	Optional details
Warmer & Air conditioner	Warmer
	Air conditioner
Key	Non-universal key
	Universal key
Wind shield and ceiling	Front windshield glass
	Rear windshield glass
	Head rain shield glass
	Iron sheet ceiling
OPS system	OPS (driving function)
	OPS (whole set)
Fire extinguisher	Fire extinguisher
Fan	Fan
Additional choice	Sling
Power switch	Power switch
Rear working light	Rear working light
Protection net	Protection net (before overhead guard)
	Protection net (at counter weight ventilation opening)
Plate	Chinese
	English
	French
	German
	Polish
	Finnish
	Persian
	Spanish
	Portuguese
	Slovenija

OPERATION & MAINTENANCE MANUAL

www.helichina.com

HELI

ANHUI HELI CO., LTD.

Add/No.668, FangXing Road, Hefei, China

Post Code/230000

Customer Service Hotline/4001-600761

Service Tel/+86-511-63648005,63689000

E-mail/heli@helichina.com



S187-11:2019

All rights reserved