

1.6-1.8t

Electric Narrow Aisle
Reach Truck

OPERATOR'S MANUAL

FOREWORD

This manual provides the proper operation to operator, service man and administrative person of the reach truck. Read this manual carefully before operation to exert the capacity and enhance efficiency of reach truck.

The manual is based on truck with standard equipments, other kinds of truck is explained only in different parts.





If you have any questions during using, please contact with HELI specified sale point for service.

This manual content might not correspond with the actual truck because of the improving of our products and using method.

Dangers during operation, inspection and maintenance can not be predetermined and monitor by us in user actual operation.

For the operation, inspection and service not listed in the manual, please take into consideration by yourself for safety reason.

Symbols are corresponding meanings used in the manual and truck plates are followed:

Symbol	Meaning
 DANGER	Indicates an imminently hazardous situation which, if not avoided, will result in death or serious injury. You must observe this instruction.
 WARNING	Indicates a potentially hazardous situation which, if not avoided, could result in death or serious injury. You must observe this instruction.
 CAUTION	Indicates a potentially hazardous situation which, if not avoided, could result in minor or moderate injury. You must observe this instruction.
 NOTE	Indicates a statement of directly or indirectly related to the safety of personal and maintain of the truck.

CONTENTS

I. About use method.....	1
1. Main use of reach truck.....	1
2. Working plan and environment.....	2
3. Travelling road.....	6
4. Selecting driver.....	6
5. Truck and load.....	8
6. Inspection.....	10
7. Transporting.....	11
8. What vehicle the reach truck is.....	11
9. Driving.....	15
10. Lifting.....	22
11. Parking.....	27
12. Inspection and repair.....	28
13. Plates.....	32
II. Operating device.....	39
1. Name of parts.....	39
2. Operating device and using method.....	40
III. Operation of the truck.....	48
1. Notes on new truck usage.....	48
2. Relationship between load and stability of truck	48
3. Load center and load chart.....	49
4. Truck stability.....	49
5. Transporting of the truck.....	50
6. Note on get onto or get out of the lorry.....	50
7. Operation of the truck.....	51
8. Battery usage.....	54
9. Loading and unloading.....	57
10. Vehicle storing.....	60
IV. Inspection.....	62
1. Inspection prior to operate.....	62
2. Periodic inspection.....	65

I. About use method

1. Main use of reach truck

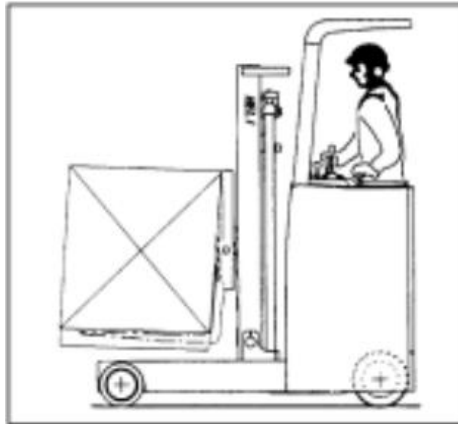

The main use of reach truck is handle and stack the loads that on the pallets.

It is prohibited to use it in prohibitive applications.

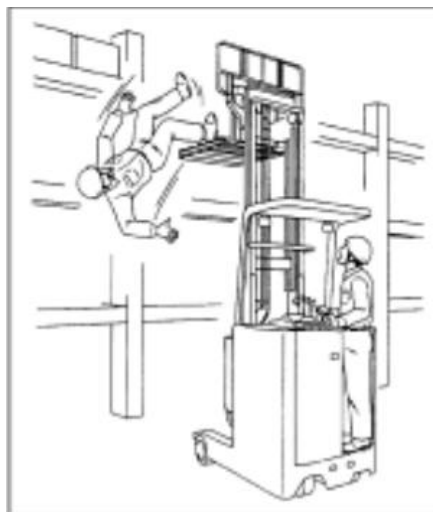

The prohibitive applications refer to travel with human riding on, lift human up, tow other vehicles and so on. The truck can not be used in the prohibitive applications.

Examples of prohibitive applications:

- Lift with people standing on fork or pallet
- Stand on the fork to press the goods
- Hoist the goods with steel wire hang on the forks directly
- Tow other trucks

- Push the loads or other trucks with forks
- Open or close the doors of other trucks with forks

2. Working plan and environment

(1) Set down working plan and discuss the plan well

You must decide the travel route and the method of working before start and discuss the safe problem well.

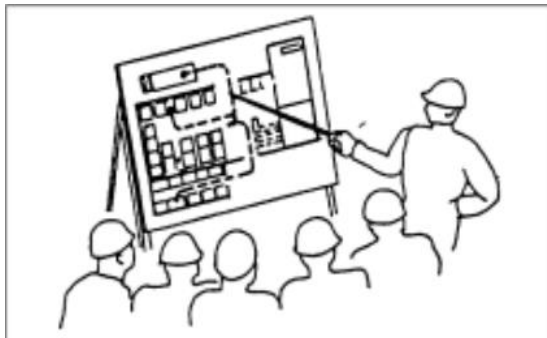

(2) Regulate limit speed

You must regulate limit speed in working environment and set striking plate in order to show clearly.



(3) Avoid dropping

Set protector on sideways or platform's edges in order to avoid reach truck dropping.

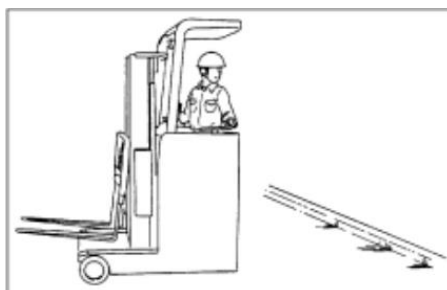

(4) Point out travel area of reach truck and clean up the load

Point out travel area of reach truck and clean up the road in the travel area in order to avoid obstacle.

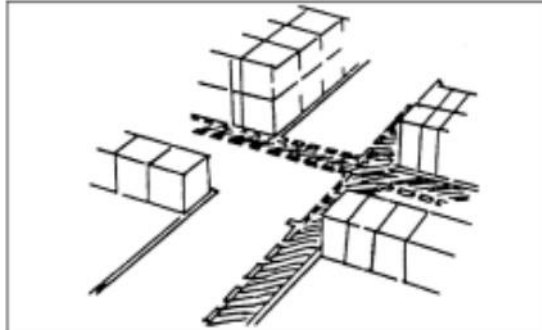

(5) Prohibit passerby to come into working area

Prohibit passerby to come into working area and prohibit the guider of the truck to contact with reach truck.



(6) Prohibit the reach truck without license to come into working area

Prohibit the reach truck without license to come into working area and set a clear sign.

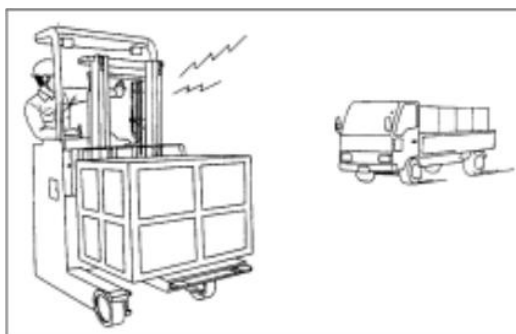

(7) Keep good condition of road surface and wipe off oil and grease

Clean up working area, keep good condition of road surface and wipe off oil and grease on the road.



(8) Lighting for operation area is needed for safety working

It is difficult to find passerby and obstacle on dark way and it is very dangerous.

Keep brightness and full of full of sunshine on way and working area.

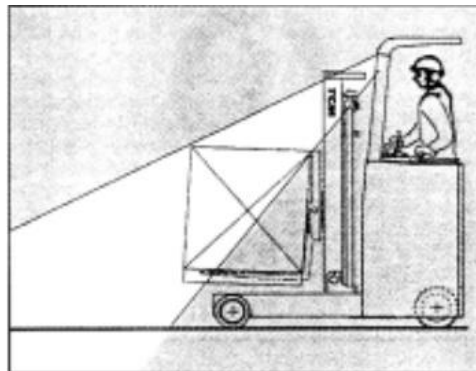

(9) Arrange a guider when working in narrow area

Arrange a guider when working in narrow area or working with other works and other truck. Do working according to the guider's lead.



(10) Affirm contact method in emergent condition

Affirm contact method in emergent condition in order to deal with fire, accident and other unpredictable things properly.



(11) Set and affirm fire extinguisher

Set fire extinguisher to avoid fire hazard, accident and other unpredictable thing. Use the fire extinguisher according to its operating rules.



(12) Safety precautions in danger

Set a clear sign in dangerous place in order to alarm the truck to keep away from assisted

(13) As a motor vehicle, the truck should only be used in the following condition:

- a) Temperature: -25°C to 40°C
- b) Relative humidity: ≤90%
- c) Altitude: ≤1200m

(14) The stability of the truck will be affected by the



power and direction of the wind outside, so do no work in strong wind to make sure people and truck safety.

3. Travelling road

(1) Prohibit travel on public road

Reach truck is the special vehicle for indoor use.

It is different to go through ramp and rough road for its small and compact structure. Reach truck will upset if go through ramp and rough road. In other hands, it will block the travel of other vehicle and person's pas for its low speed. If the wheel is out of round or the status of the road surface is not good, it will raise the running noise.

Prohibit travel on public road. Only use indoor.

4. Selecting driver

(1) Wear safety clothes



Please wear proper safety clothes when driving. Improper clothes may be caught by operating levers or pedal which may cause truck mis-moving.

- Be sure to wear safety helmet and safety shoes.
- Please wear other necessary protective clothes according to working area condition

(2) Safety education on goods stacking

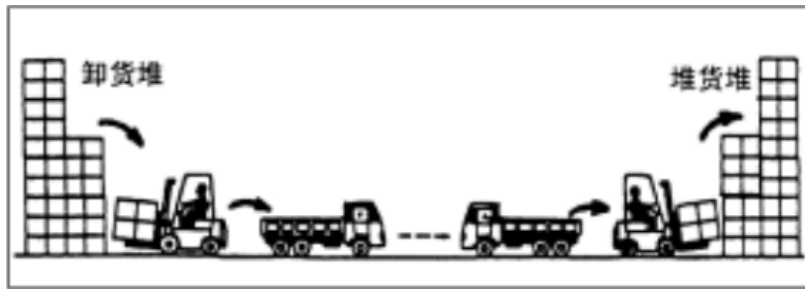

Goods stacking is for storage, it is not to put goods on platform, but stack goods together.

If goods are not stacked accurately, goods will collapse and it will threaten driver and other people.

It is necessary to make safety education for the people carrying out stacking operation.

(3) It is essential to make safety periodic education for experienced driver

- Periodic education every five-year. Structure of vehicle will change and rule of law will change for technique renovation.
- Make safety education when operation method and equipment using method have important change.

Because the fast development of truck structure, application of microcomputer and automatic devices and changes of law, it is necessary to receive the courses from expert.

(4) Do not let someone operate the reach truck when he is tired or have poor health.

Do not let someone operate the reach truck when he is tired or have poor health because accidents may be caused by absent minded.



5. Truck and load

(1) Do not use the reach truck when its overhead guard is dismantled.



(2) Modifications shall not be carried out by user at will.

Modifications on truck or attachments that affect performance, safe construct and strength shall not be performed.

For example, modifications that enhance the weight of counterbalance shall not be performed without the written approval of our company.

(3) Decal must be put on obvious position

You must paste new plate when it damaged or lost.

Check the plate in periodic checking.

(4) Do not over trust overhead guard



The overhead guard is used to protect the driver when goods are falling from the top of head. But it does not mean it can withstand the impact of all falling goods.

(5) Using a hard pallet

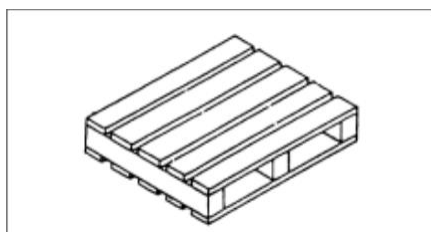

The pallet must endure the weight of load. Worn-out pallet must be repaired in time.

(6) Make sure to load and unload the goods in stable and safe condition.

Avoid off-center loads or falling loads. Make sure to load and unload the goods in stable and safe condition.

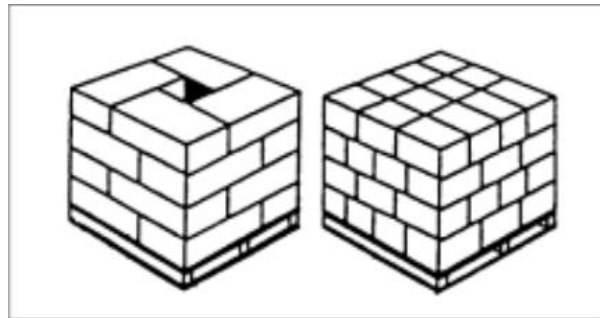

(7) Be careful of the capacity of ground



The reach truck is heavy. 80%-90% of reach truck weight is center on front wheel when the reach truck is loaded. You must investigate the ground of warehouse, and enhance the quality of ground if necessary.

6. Inspection

(1) When operation, have a good habit of inspection.

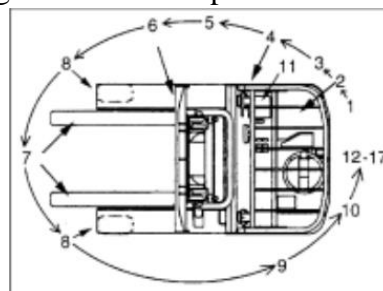

Operator should inspect the truck before operation and if there is any fault, report to administrative person.

(2) Inspect regularly and make a record.

Inspect monthly and annual, repair it immediately if there is any fault. the inspection should be carry out by professionals because special technique and equipments are needed. The record of inspection must be saved three years.

(3) Change the important parts regularly.

	Name of safety parts	Term
1	Pipe for lifting system	1~2
2	Chain s of lifting	2~4

The items listed above must be replaced for a fixed period because they are very important for safety.

(4) It is strictly prohibited to operate fault truck.

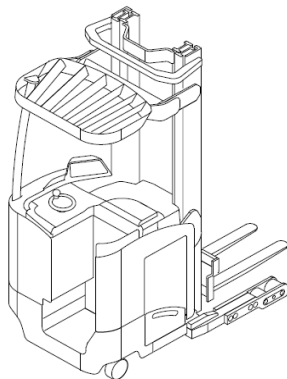

Before driving you should check truck carefully. If there is any fault, hang a warning plate on the truck and then remove the key and report to the administrative person.

(5) Assign a guider for truck maintenance and attachments working

Assign a guider and do according to his command.

The truck body and parts are heavy and some place have high pressure. Be care when repair.



7. Transporting

Load and unload the goods on flat and solid surface. Besides, take care of connecting plate length, width and strength and make sure it is reliable and safe. In rainy days, use anti-slip connecting plate or stop working.

When handling goods from or to the truck, it is very safe to use the truck assembled with jack and winch.

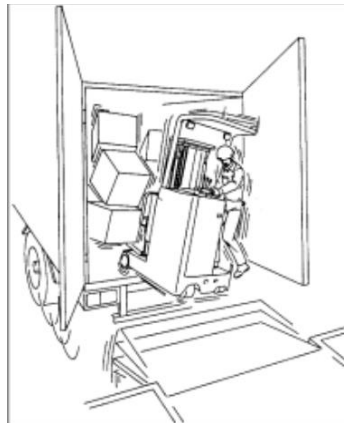

8. What vehicle the reach truck is

(1) Keep the balance of the truck

The reach truck is equipped with the fork in the lifting system that can move forward and backward. The supporting point of the reach truck is its front wheels which balance the truck's center of gravity with the goods'. For this reason, the center of gravity of the truck together with the goods' are important for truck safety.

The stability of the truck will be improved a lot when the fork is drawn back.

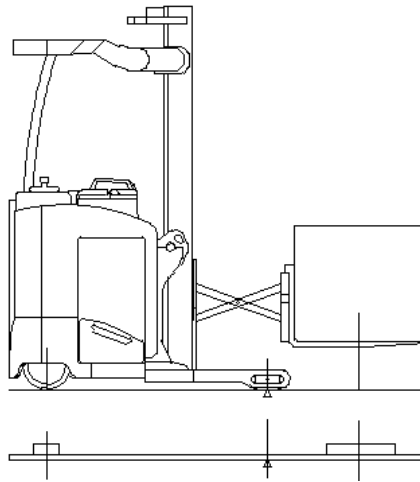

Load wheel supporting point load weight

(2) Be sure the center of the goods' gravity

The goods can be boxlike, board like, stick and all other kinds of shape.

To estimate the stability, it is important to well-known the center of gravity of all kinds of the goods shape.

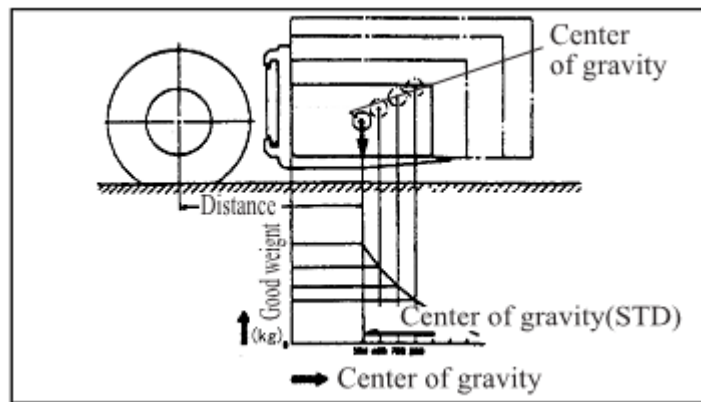

(3) The variety of the center of its gravity

The combine barycenter of the truck itself and the loading determined the truck's stability. While unloading, the combine barycenter is the truck's center gravity itself. While loading goods, the barycenter combined the truck's barycenter with the loading goods. The barycenter changed while the mast tilt forward or backward or lift the fork arm. Tor this reason it changed the combine barycenter also. In addition, the truck's barycenter depend on the following facts.

- The size, the weight and the form if the loading
- The height of the loading
- The tilt angle of the wheel
- The material of the wheel
- The acceleration, deceleration and the rolling radius of the truck
- The road status and the gradient of the road
- The type of the attachment

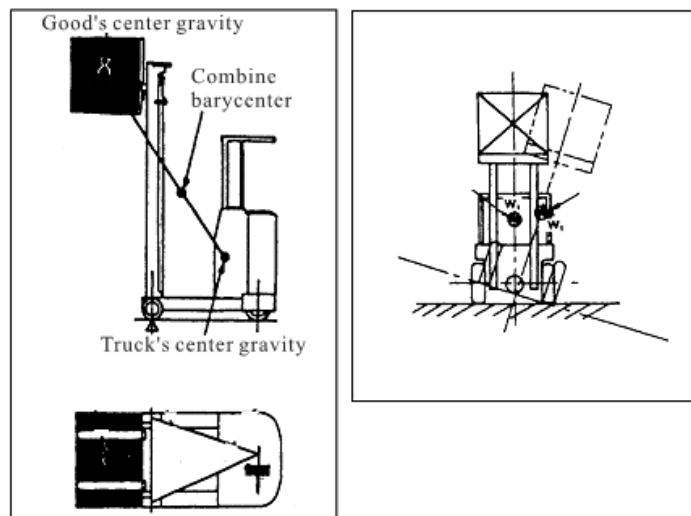

To level off the truck, the combined center-of-gravity shall be located in the interior of triangle composed by the ground contacting points of left front wheel, right front wheel and drive wheel. If the combined center-of-gravity exceeds the position of front wheel and tipping forward with the front wheel as supporting point will be resulted. If the combined center-of-gravity exceeds the right or left side, tipping towards left or right side will be resulted.

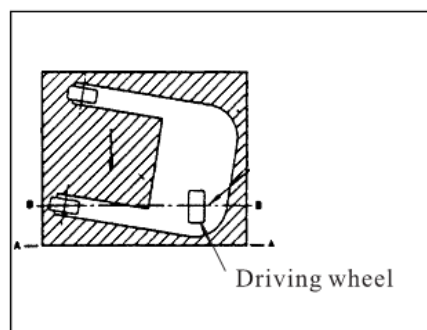

(4) The max loading weight (the loading weight and its center)

The horizontal distance from the center of gravity of the loading to the bottom of the fork arm (in front of the load backrest) called the load center distance. The maximum weight that can load in the just load center called the maximum loading capacity.

The capacity chart showing the relationship of the maximum loading capacity to the load center distance. It paste in the truck as a plate. The load center moves forward to the fork arm as well as the combine weight and the load capacity decrease too.

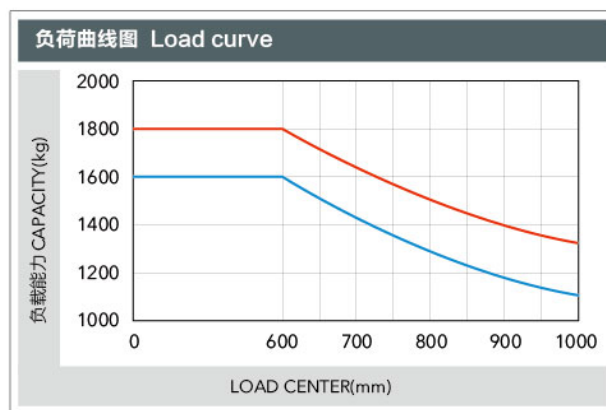

load curve

(5) Acceleration, deceleration and the rolling radius of the truck

A quiescent object will be keeping its state if out of outside force. And it is applicable to the moving object also. This is called inertia.

The inertia is of the same direction when the truck moving forward. The inertia will increase with the increasing of speed. While braking, the inertia will make the truck overturn to the forward. It is dangerous while braking emergently for it will largen the overturn force. in addition, when rolling the truck, the rolling center's centrifugal force acts. The truck makes the truck overturn to the outside, especially the stably area around the truck. So you should decelerate the truck while rolling overturn.

When the loading is lifted, the combine barycenter will rise too. It is dangerous to overturn to the forward or sideward.

9. Driving

(1) Read this manual before driving

Prior to operation, read this carefully to ensure safety and efficient material handling by proper driving and maintenance,

This manual should be kept by operator and read it carefully.

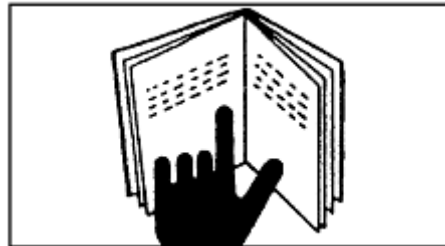

(2) Attention before the start

When you start the truck, please obey the following rules:

- Check if all operating levers position are in neutral position
- Make sure foot is away from braking pedal
- Begin operation after ensuring the safety around



WARNING

Operate the truck on designated operating position.

- **Prohibition of reach lever operating when your body is between the mast and chassis or this will lead to a dangerous condition unexpectedly.**
- **Operate the mast on the designated operating position.**

(3) Change the direction after the truck is stopped.

Sharp direction changing is very dangerous.

(4) Do not drive or make a turn with forks lifted up.

When travelling with lifted forks, this could cause an unstable condition and a turn over of the truck.

(5) Lower the center of gravity

Tilt the mast backward and keep the fork about 20cm above the ground when

travelling in order to lower the center of gravity.

(6) It is prohibited to lift or tilt sharply when loaded.

Do not lift or tilt the mast sharply when it is loaded. If so, the truck may have a danger of overturn.



(7) Rude operation such as sudden start, sudden stop, sudden steering and so on are prohibited.

Rude operation such as sudden start, sudden stop, sudden steering and so on are prohibited. when steering, please slow down. The truck will have a danger of overturn when making a sharp steering without load because the rear of the truck is very heavy.

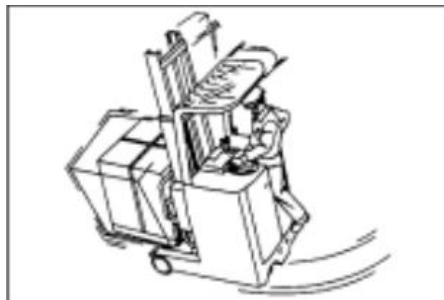

(8) Driving on a slope

- Do not make a turn and travel horizontally on a slope or truck may have a danger of overturn.
- Take care of the road height when there is a sharp slope so as to avoid fork or pallet contacting with ground.
- When traveling on a slope without load, travel backward when go up the slope and travel forward when down a slope.
- When traveling on a slope with load, travel forward when go up the slope and travel backward when down a slope.

- When down a slope, make full use of brake system.
- When travelling on a slope, do not make engine power off.

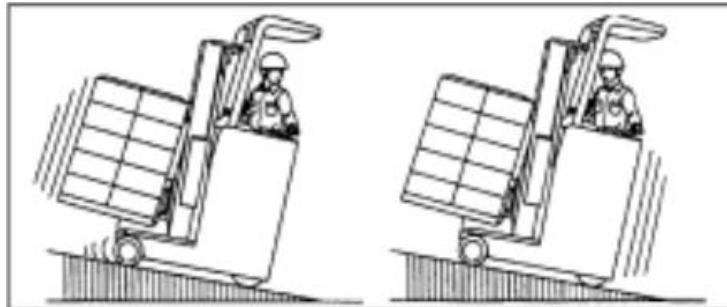

(9) Do not drive into a weak road shoulder.

Do not drive into a weak road shoulder because it has a danger of collapse.

Keep a safe distance with the road shoulder in narrow road so as to avoid truck falling.



(10) when operating in a container

- It is prohibited to travel on the platform edge because it has a danger of falling down which may even cause death.
- Check the connecting plate capacity and its safety. It is prohibited to use improper connecting plate.
- Apply the hand brake of the lorry and wedge the four wheels to prevent it from slipping.
- Lift the truck with jack to prevent the truck from sinking when the reach truck travels in because of heavy load.

- Slow down and take care of the connecting plate safety.
- Take care of the passersby.
- Inform the lorry driver not to operate the lorry until the operation is finished.
- Fix the connecting plate to avoid slipping.

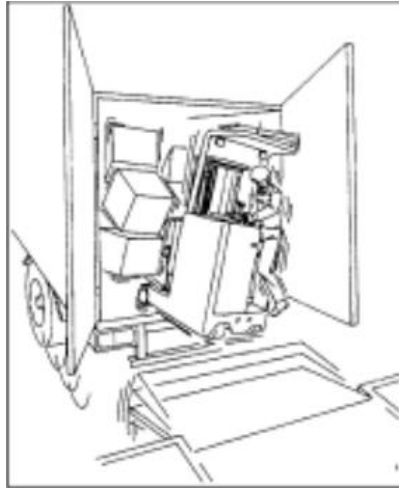

(11) It is prohibited to use people as a balance weight or operate with two drivers.

It is prohibited to use people as a balance weight or ride any people except driver.



(12) When travelling backward, it is dangerous to depend on back view mirror only.

Face backward and travel after a direct check of the backward.



(13) When travelling backward with high goods, assign a guider.

When the goods are high, the driver has poor front view. Face backward and travel after check. Assign a guider for the safety of goods and around.



(14) It is prohibited to operate the truck until checks are all finished.

It is prohibited to operate the truck until checks are all finished.

(15) It is prohibited to operate the truck with oil or water.

When operating the steering wheel or levers with oil or water, it has a danger of out of control.

(16) It is prohibited to get on or out of truck quickly.

It is prohibited to get on or out of truck quickly. It is very dangerous.

When getting on or out of the truck, step on the pedal to support your body when the truck is stopped completely. Besides, keep the pedal clean and at good condition. If it is damaged, repair it at once.

(17) It is prohibited to operate the truck from other position except driver's seat.

- It is prohibited to operate the truck from other position except driver's seat.
- Keep your body always under the overhead guard.
- It is not allowed to put food and hand out of truck body.



(18) Check the safety around before start.

Check the safety around before start. Sound the horn and then travel forward.

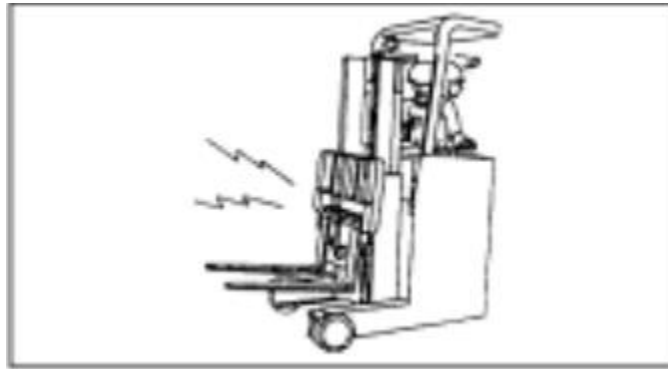

(19) Do not shut down the engine during travelling.

The powered steering unit can not work when the flame is out.

(20) Safety during travelling

- During travelling, concentrate on front view or serious accident may be caused. Slow down when giving pass to other trucks and keep a proper distance with other truck.
- When a limited speed is regulated, please keep to it.
- It is prohibited to overtake other trucks in places with poor view such as turn, cross and so on.
- Stop and sound the horn to ensure the safety in narrow aisle or places with poor view.
- Stop to check the safety when turning or travel across a road.



(21) It is prohibited to travel with working device reaching out.

- It is prohibited to travel with mast reaching out. It has a danger of overturn when braking under this condition.
- Travel with working device drawn back.

(22) It is prohibited to travel on ground with ponding or wet floor.

When travelling, avoid ground with ponding, wet floor or hallow.

(23) It is prohibited to travel on soft road.



(24) Do not run over bumps and obstacles.

Do not run over bumps and obstacles. If has to, please take care.

(25) Do not travel on slipped road.

(26) Pay attention to the ground loading limit.

When operating in a building or elevator, pay attention to the ground loading limit and it is prohibited to overload.

(27) Notes when travelling in places with limit.

When travelling in the places with height or width limit, pay attention to the following notes:

- Make sure there is enough width and height when travelling across.
- Keep your foot and hand inside of the truck body.
- Please ensure the safety around.
- Please pay attention to the wire and barriers in and out of the room.

(28) Please take care if rear part rotation because it is different from the automobile.

The rear part will rotate to the outside greatly when travelling forward. Be sure to keep a safe distance from the wall.

(29) Take adequate brake into account and brake a little earlier.

The wet road had longer brake distance than normal road. So brake a little earlier.

(30) Brake distance gets longer when braking down a slope or on a wet road.

Brake distance gets longer when braking down a slope or on a wet road. Take adequate brake into consideration and be careful when driving.

(31) Practice operating truck carefully and be familiar with the truck.

Before operating truck, practice carefully and be familiar with the truck. Please drive the truck carefully even you are familiar with the truck.

(32) When operating more than one truck

When operating more than one truck which even have the same performance, the brake, accelerator and lifting device may be different.

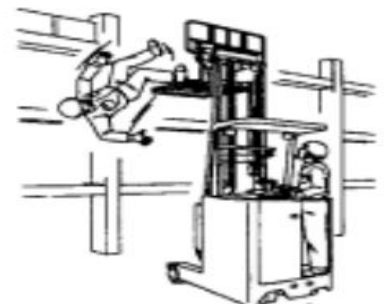
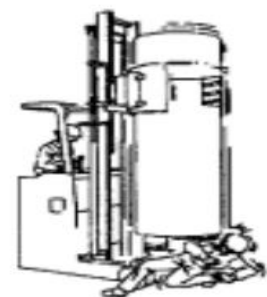

10. Lifting



WARNING

- No overloading

Do not overload and observe the load chart.

When travelling with an exceed load, the rear wheel will be raised from the floor. So driving and steering can not be controlled. This condition could lead to an accident.

- Do not stand under the forks.

It is prohibited to stand under the lifted fork.

People may get injured when fork is falling down quickly.



- Do not stand on the forks.

Do not lift or lower the truck with people stand on.

It has a danger of falling down and people may get injured.

- It is prohibited to put hand and foot into mast or between the mast and truck, or it has a danger of hurt.

(1) Prohibition of off center load

Keep the goods' center of gravity agree with the truck's center. Do not travel with off center load.

(2) Lay the goods against backrest (to the bottom of the fork)

When travelling, goods should lay against backrest. The goods height should not exceed the height of backrest, or goods may slide to the operator's side and the operator may be hurt.

(3) It is prohibited to unload and load when goods are unstable.

It is prohibited to load and unload when goods are unstable.

Fix the unstable goods before travelling.

(4) Take care of the stability when making a double stack.

When making a double stack handling, fasten the loads with rope to protect falling of loads.

(5) It is prohibited to load the goods higher than backrest.

It is prohibited to load the goods higher than backrest. Do not handle such goods because goods may slide to operator side and death may be cause.

(6) It is prohibited to tilt the mast forward with goods lifted up.

It is prohibited to tilt the mast forward with goods lifted up, or goods may slide down and there is a danger of turn over.

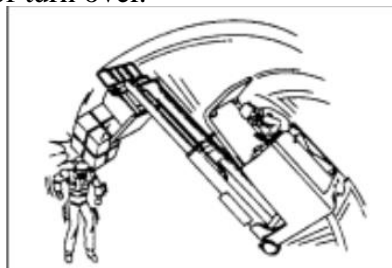

(7) It is prohibited to lift, reach forward and travel with mast tilt forward.

(8) It is prohibited to load and unload when the truck is leaning.

(9) Loosen chains

When the chains are loosen, there is a danger of catching loads and rack by forks or falling of loads and overturning of truck. Always check the chains to prevent it from loosening.

(10) It is prohibited to use the truck in not allowable application.

- Do not use it to open or close the door of warehouse.
- Do not use it to push other trucks.
- Do not lift the truck with steel rope directly hooked at the fork.
- Do not tow other trucks.
- Do not pull or push goods and goods has a danger of falling down and be broken.

Never tilt the mast with loads upraised 150cm or more, otherwise there is a danger of overturning.

(11) Adjust the fork space to proper position

Adjust the fork space to proper position according to goods size.

(12) Adjust fork space with foot.

Adjust the fork space with foot. If with hand, there is a danger of being caught.

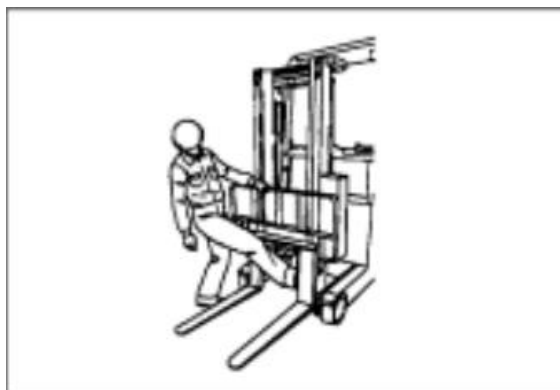

(13) Ensure the fork is locked.

After adjusting the fork space, lock the fork hook.

If it is not locked, the goods may move during travelling and it has a danger of

falling down.

(14) Make sure lift chains are equivalent in tension

Make sure lift chains are equivalent in tension. If lift chains are not equivalent, there is a danger of falling of loads and overturning of truck.

(15) Be care of the tip of forks, and do not hurt person or goods.

The fork tip is sharp and it has a danger of hurting someone. Beside when goods are caught by fork tip, the truck has a danger of moving towards unpredictable direction. It is very dangerous.

(16) Prohibition of passenger entering into working place

In working place, no passenger is allowed to enter except guider.

(17) Do not approach to the truck when it is loading and unloading.

Do not approach to the truck when it is loading and unloading.

(18) Please follow the director when working together.

The driver should follow the guider to work.

(19) Use pallet with enough strength

Use pallet with enough strength. Goods may fall down when damaged pallet is used.

(20) Take care when handling goods with large size

Careful driving should be taken when handling long or wide loads.

Lift or lower the goods slowly to take care not to collide with other goods.

Handle the goods at low height and take care to balance it. Turn slowly in order not to move the goods.

(21) Never approach overhead power cables and pipelines with any part of your truck.

Make sure that there is sufficient clearance between mast and ceiling or entrance of a structure. Once hit, it will lead to load's falling and overturning of truck. Be careful, when the mast lifted up.

(22) Prohibition of unloading the loads at high height position of forks.

It is not allow to unload the goods at high height position of forks by other trucks. When the loads is off center, it could lead to overturn the truck and falling loads. Do not hold down the loads by hands. There is a danger of load's falling.

(23) Do not press the goods by people sitting on the goods.

Do not press the goods by people sitting on the goods. The truck may have unpredictable moving and goods may falling down. It is very dangerous.

(24) Prohibition of stacking and unstacking goods when the forks lift up high.

Do not stack and unstacke goods when the forks lift up high. It is dangerous when stacking and unstacking loads by the movement of truck. it leads to damage of loads or overturning of truck.

(25) Prohibition of reaching movement when the goods approach the floor.

Do not reach forward or backward when the loads approach the floor.

(26) Do not push or pull the goods with reach movement.

Do not push or pull the goods with the cylinder force.

(27) Do not lift goods with steel wire directly hooked on the fork.

It is very dangerous when lifting goods with steel wire directly hooked on the fork or attachment because steel rope may be cut or fall.

Truck may rotate to both sides when lifting goods with one fork. It is very dangerous.

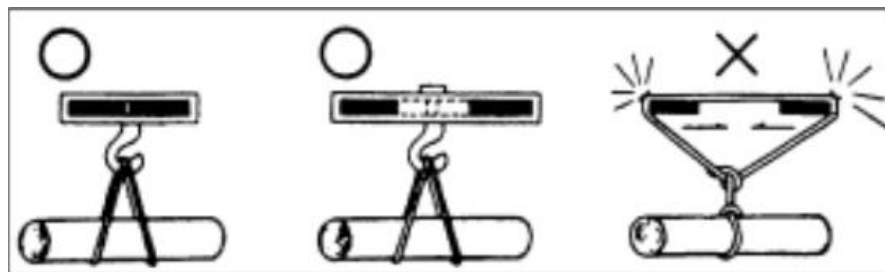

Please use hook or cantilever hanger to hang up goods.

When steel wire or rope is used, choose one with enough strength according to goods weight. Make sure the steel wire or rope is short as possible and hanging angle

is reasonable.

Please drive and steer slowly and carefully when hanging up loads with steel wire or rope. It could lead to overturning of truck when loads shake severe. Please lower the loads as possible.

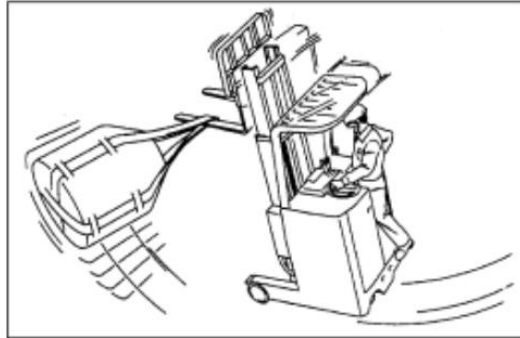

11. Parking

(1) Obey the following working orders before leaving the truck:

- Lower the fork to the ground at proper place.
- Tilt the mast or fork bracket assembly forward and make the front part of the trucks on the ground.
- Press parking brake switch.
- Place directional switch lever in neutral.
- Place the key switch in OFF and turn off the key switch.
- Remove the key.

(2) Park at reserved place.

(3) Parking place should be hard enough.

(4) Park a place which does not disturb traffic.

Please park the truck at a place which does not disturb traffic. and do not park the truck at a place close to exit, ladder and the place where to place fire extinguisher and so on.

(5) Do not park on or near an inflammable object.

(6) Wedge the wheels when parking on a slope.

When it has to park on a slope, wedge the four wheels to avoid truck moving

except normal parking orders.

(7) Parking of fault truck

When the forks could not be lowered by fault, place a large mark at the front part of forks in order not to be hit by other truck or walkers. Park the truck off road or at a place which does not disturb traffic. Make people can not go through the lifted fork. It is very dangerous.

(8) When the truck has fault, remove the key and place a warning plate.

Turn the key witch off when the truck has fault. Remove the key and place a warning plate.

(9) Repair of the fault truck

If the truck has fault during use, tow the truck away in time to avoid it disturb any other trucks or people.

12. Inspection and repair



inspecting the truck prior to operation should be done for safety operation and keep good condition of the truck. this is duty in law. Only trained and authorized serviceman shall be permitted to service the truck. improper inspection and repair is bad for truck and it is dangerous.

(1) Inspection on the truck should be done on a flat floor.

Inspecting and servicing trucks should be made on a flat floor which is dry and clean.

(2) Pay attention to air ventilation when inspecting inside of the room.

(3) Make sure fire extinguisher are ready and be familiar with its usage.

(4) lower the forks to floor prior to inspection.

(5) Turn the key to OFF position and disconnect the battery connector.

(6) Before operation, place all controls in neutral position.

(7) Wipe off split oil and grease at once

Please wipe off split oil and grease at once, and wipe off hydraulic oil as soon as excluding. Otherwise, it is hard to find crack when covered with dust.

(8) Prohibition of fire especially when using a cloth to clean oil, grease and fuel.

It is easy to cause a fire. Prohibition of fire especially when using a cloth to clean oil, grease and fuel.

(9) Wear suitable working clothes.

(10) Wear safety wearings such as helmet, shoes, glass and gloves.

(11) Do not put foot under fork.

(12) Take care not to put hand between front plate and bonnet

Be careful not to be squeezed when front plate is open.

(13) When inspecting with mast lifted high, take safety measures in case of fork and mast falling down.

When inspecting with mast lifted high, put supporting block under mast in case of fork and mast falling down.

(14) When working together, assign a guider and follow his command.

(15) Please use proper tools.

Please use proper tools which are suitable for inspection and serving, it is dangerous to use improper tools.

(16) Do not use tools out of its function.

(17) Take care of spurting of hydraulic oil which is at high temperature.

After truck's operating, the hydraulic oil became high temperature and high pressure. In this condition, do not let out hydraulic oil or exchange filter and so on. The high temperature hydraulic oil spurts out could lead to a burn.

(18) Hydraulic system has a high pressure and please decompress before inspection.

Hydraulic system often has a high pressure, please decompress before inspection. Before checking leakage, please wear goggles and rubber gloves. It is dangerous that the high pressure hydraulic oil spilled on the skin or splashed in eye.

(19) Carefully inspection of battery and its pipeline

The pipelines of battery are easy to burst. It is dangerous. Please check it by appointed factory.

(20) Please consult a physician immediately when spilled on the skin or splashed in eye by the high pressure hydraulic oil.

(21) Be sure to disconnect the battery plug when inspecting the electrical system

Do not touch the electric conductor of the battery when inspecting high voltage equipments. Otherwise it causes a serious burn. Place the key switch in OFF and disconnect the battery. when being struck by a high voltage shock, consult a physician immediately.

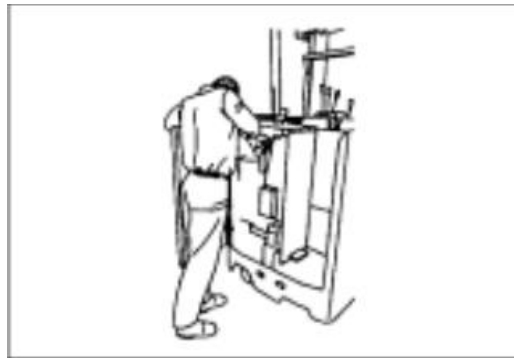

(22) Do not use a mast assembly instead of a ladder

Do not use a mast assembly and a bracket instead of a ladder to climb and work. It is dangerous when the mast and the backrest fall suddenly. It could lead to snipping your hands or feet. And there is a danger of falling down from the mast.



When the truck is jacked up, do not enter under the truck. There is a danger of falling down suddenly.

- Before jacking up the truck, remove the goods from the truck.
- Operator should leave the truck when jacking up the truck. When wheels rise up from ground, stop jacking up and put blocks under the truck to prevent the truck falling down.
- Before jacking up, wedge up truck wheels.

- Use crane or travelling crane when hanging up the truck.
- Hook the wire at appointed position when hanging up the truck.
- Use wire rope which has sufficient strength and no damage when hanging up the truck.

(23) Precaution of battery using

- The electrolyte of battery is made of dilute sulphuric acid. It is corrosive. When the electrolyte adheres to eyes, skins and clothes, wash with plenty of water.
- If electrolyte splashed into eyes, wash with plenty of water and receive doctor treatment.
- Use glasses when using battery.
- When electrolyte is swallowed accidentally, drink plenty of water, egg white with raw eggs or milk with salad oil at once. Then receive doctor treatment in time.
- There is danger of explosive because battery produces hydrogen gas. so do not use lighter or other objects with fire near the battery.
- Do not disconnect the plug during charging.
- Do not make short circuit between both terminals by bolt or tool. When the terminals are loosen, there is danger of explosion because of poor connection. Make sure the terminals are fixed firmly. When reassembly, make sure the terminals are connected correctly.
- When cleaning the battery, close the vent caps of the battery securely.

(24) Charge the battery at a place where is well ventilated.

Hydrogen gas is occurred when charging the lead acid battery; it can cause an explosion and a fire. Charge the battery in a well ventilated place.

(25) Prohibition of a fire when charging the battery.

Hydrogen gas is occurred when charging the lead acid battery; it can cause an

explosion and a fire. Keep away from a fire.

(26) Charge the battery at a temperature lower than 35°C .

Hydrogen gas is occurred during charging lead acid battery. The battery is heated for chemical reaction. Please charge the battery when its temperature is lower than 35°C. When its temperature of lead acid battery is higher than 50°C, please stop charging at once. Recharge until its temperature is lower than 35°C.

(27) The battery of the truck has a high voltage.

The truck which uses battery to provide drive power has a high voltage. The battery's voltage is up to 48V commonly. Do not touch the electric conductor of the battery when installing and serving. There is a danger of get burnt.

(28) Wearing safeguard

When servicing the battery such as refilling electrolyte and adjusting the specific gravity of all cells, please wear goggles, rubber gloves and boots.

(29) Be care of static electricity when clean the battery.

Do not use a dry cloth, a chemical fiber cloth for cleaning the battery surface. And do not cover the battery by a vinyl sheet. It causes a ignite explosion by a static electricity.

(30) Be care of a static electricity of our body.

Please clear s static electricity of our body away from the battery before inspection.

(31) Please obey the government's rules when handle with the waster of the forklift truck.

The waster of the forklift truck must be reclaimed obeying the government's rules. Do not drain the waster at will.

13. Plates

The plates sticking on the trucks are used to explain to the driver how to operate the truck and what to pay attention to. When any of them fall off, please re-stick it at

once. Some plates examples are followed.

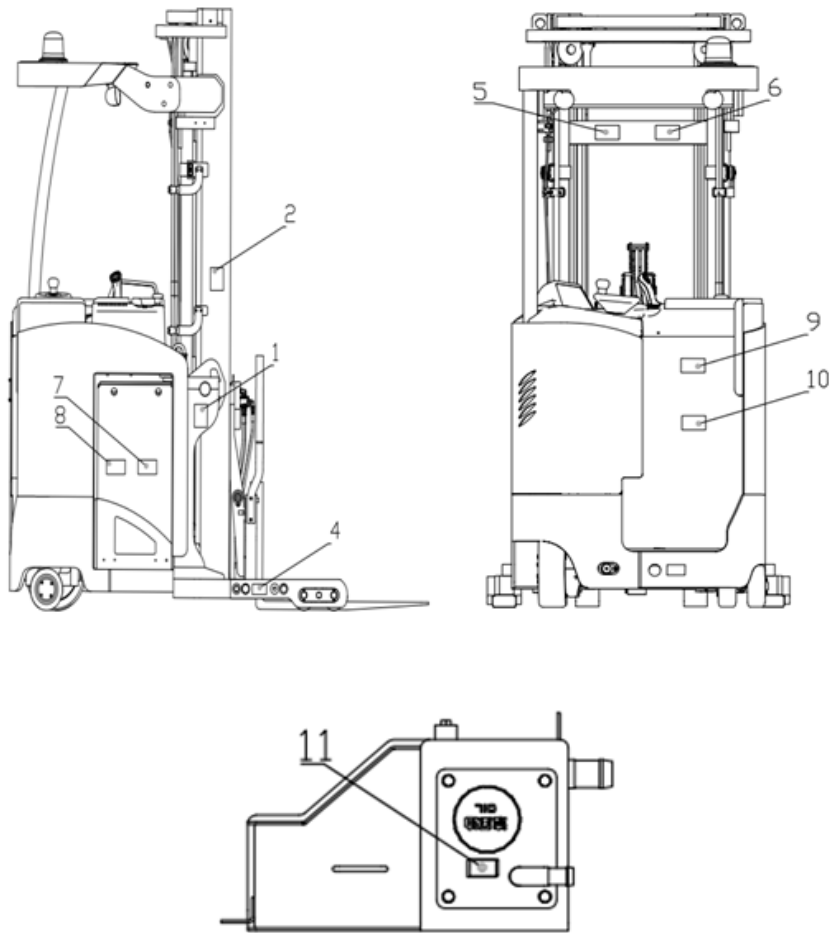

1. Reach truck plate

Electric Reach Truck		HELI	
Model	<input type="text"/>	Configuration No.	<input type="text"/>
Rated Capacity	<input type="text"/>	Total Weight	<input type="text"/>
Load Center distance	<input type="text"/>	Total Weight (without battery)	<input type="text"/>
Rated Voltage	<input type="text"/>	Battery Weight(Max)	<input type="text"/>
Serial No.	<input type="text"/>	Battery Weight(Min)	<input type="text"/>
No. of Manufacture License	TS2510341-2020	The Year of Construction	<input type="text"/>
 		Compliance With ISO 3691 Add: 163 Woyun Road. Hefei. Anhui, P.R. China ANHUI HELI CO., LTD.	

2. Safe plate



**DO NOT STAND
UNDER/ON FORKS**



3. Lubricating chart

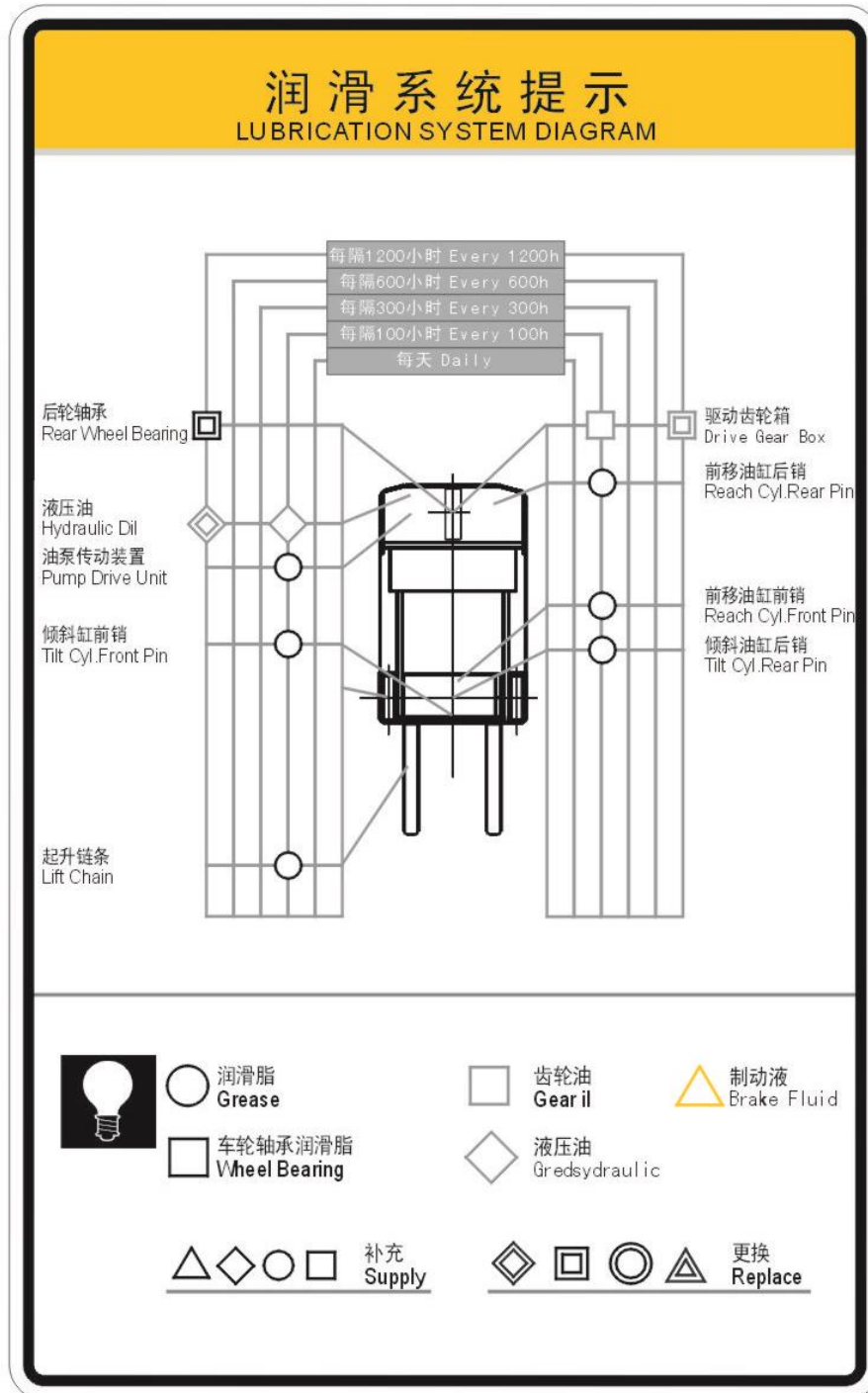

4. Sling plate



5. Caution plate



6. No entry into the space behind the mast



7. Routine battery use



ROUTINE BATTERY USE

1. Immiting appropriate distilled water or diluted vitriol slowly while replenishing electrolyte, The electrolyte level must be proper. The level exceeding is prohibited.
2. Open all lids of the battery and keep ventilated while charging.
3. Keep all lids close to avoid electrolyte splashing while use battery.
4. While changing battery, keep the battery box vertically.And lower it slowly to avoid electrolyte overflowing.
5. Clean the battery bracket regularly to avoid that the bracket is corrupted by electrolyte.

8. Routain battery maintenance



ROUTINE BATTERY MAINTENANCE

1. Be sure the battery voltage not less than 85% of the rated voltage while using.
2. The battery should be recharged within 24 hours, Never overcharge the battery during charging it.
3. Replenishing distilled water regularly to keep the electrolyte level normal.
4. If the battery is not in use for a long time, Please remember to recharge it once a month.
5. The battery temperature exceeding 55°C is strictly prohibited, keep away from flame to avoid explosion.
6. Keep the battery surface dry and clean.

9. Load capacity

实际承载能力 Actual Capacity

门架型式 Mast Model

最大起升高度 Max. Lift Height

属具型式 Attachments

最大起升高度A(mm) Max Lift Height

承载能力 G(Capacity)(Kg)

600 700 800

载荷中心距B(Load Centre Distance)(mm)

CE 安徽合力股份有限公司 ANHUI HELI CO., LTD.

门架垂直状态承载能力 capacity when the mast is under the vertical conditon

The diagram shows a vertical mast with a load G suspended from it. Dimension A is the height from the base to the load, and dimension B is the horizontal distance from the vertical centerline to the load. The mast is shown in a vertical position.

10. General information when operating

GENERAL INFORMATION WHEN OPERATING

Start

Persons who have not been properly trained must not operate this forklift truck.

Check all controls and functions before operation. Do not operate if malfunctioning.

Drive and operate the truck smoothly at all times.

Driver should apply handbrake, switch off engine and alight from truck during fuelling or battery charging.

To use seat equipped with belt, you must fix the belt around your waist on the seat in order to guard against falling from the truck in case of overturning.

Operate

Do not carry unsecured loads

Overloading is prohibited.

Only operate the truck when sitting in the seat.

Never lift loads on a single fork

Take care not to unbalance loads at high levels

Beware low heights

Forks must be fully under load

Use minimum tilt at high levels

Travel

- Slow down when driving in the wet.
- Beware when driving on slopes. When slope is greater than 10% drive forwards up the slope and drive backwards down the slope.
- Take caution when driving on uneven surfaces.
- Never carry people on the forks.
- Do not turn on slopes.
- Always lower load and tilt back when travelling.

Stop

When parking truck lower forks to the ground, tilt the mast upright apply the handbrake and switch off the engine. Never park on a slope.

11. Oil adding plate



II. Operating device

1. Name of parts

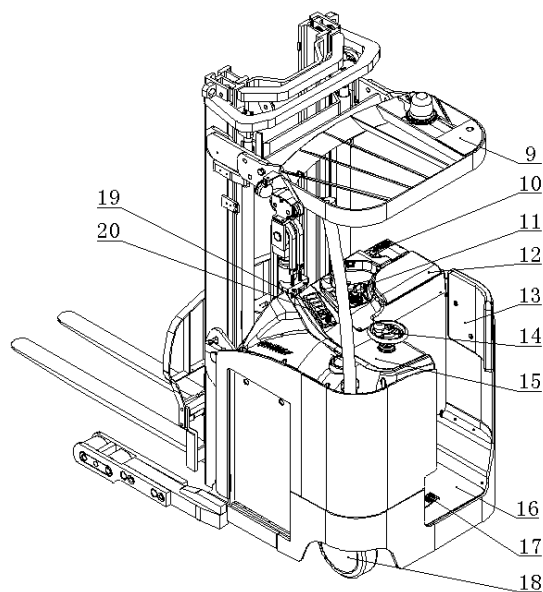
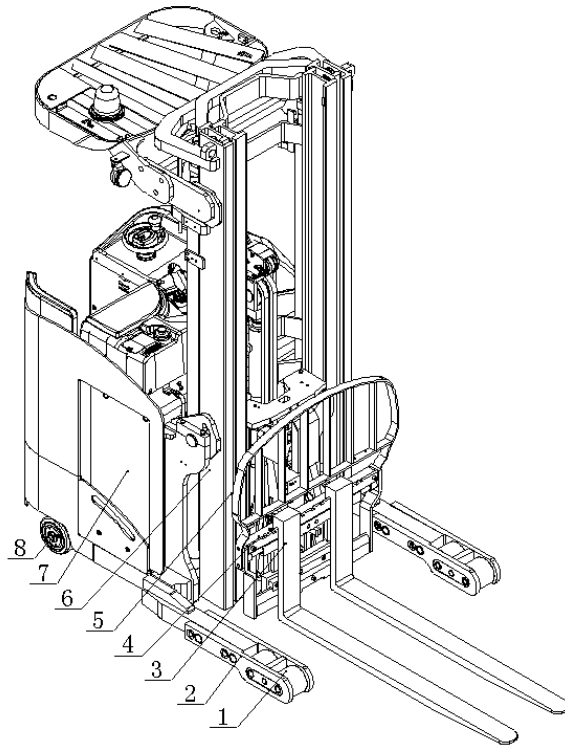

- (1) support wheel (2) front straddle leg (3) fork (4) fork bracket (5) backrest
(6) mast (7) battery (8) auxiliary wheel (9) overhead guard (10) power off switch
(11) integrated knob (12) hand mad (13) brake pedal (14) steering wheel
(15) accessories (16) pedal (17) brake pedal (18) drive wheel (19) dashboard
(20) key switch

2 Operating devices and using method

1) Crystal displayer

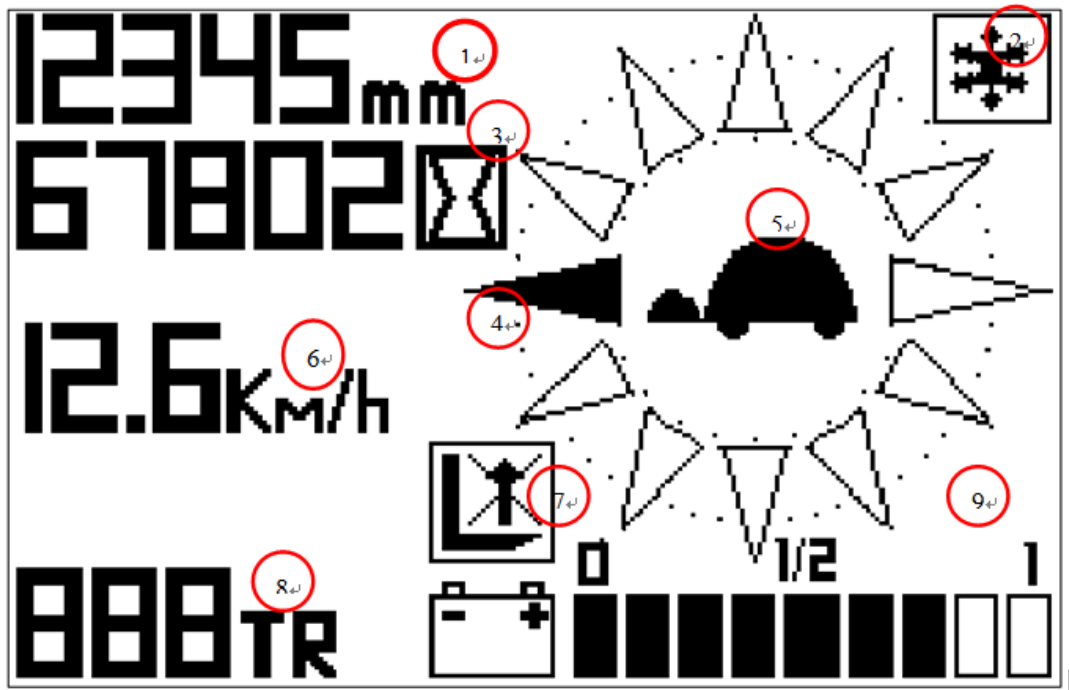

(1) Fork height indicator (optional)

It is used to display the current fork height and the unit is mm.

(2) Heating in cold environment indicator (optional)

When the electric heating is started in cold storage, the indicator shows.

(3) Hour meter

When the hour glass symbol flickers, it means it is recording time. The number shows the current working hours.

(4) Wheel angle indicator

It shows the current wheel angle and direction. There are 12 arrows and only one arrow is highlighted.

(5) Working mode indicator

It shows current working mode. The working mode has "1-4" and soft gears.

(6) Speed display

It shows current truck speed and the unit is km/h

(7) Lifting lock indicator

It shows lifting is locked.

(8) Fault code indicator

It shows the fault node and fault code.



(9) Electricity quantity indicator





It shows the current electricity quantity.



Meter usage instruction

(1) Turn on the key switch and the meter system carries out self checking after it gets electricity. Battery electricity quantity, truck speed, traction hours and wheel angle is shown on the home page.



(2) Safety switch and brake display: the truck is braked when safety pedal is released. At that time the truck can not travel but it can steer, lift, moving forward and backward, tilt and the symbol  on the meter is on all the time. When stepping on the safety pedal, the truck can travel and the  is off.

Press the  button and  light on the meter is on. At this time, the truck is under brake condition and the traction system of the truck can not work. press the  button again, the  light on the meter is off. At this time, the truck is stand by and traction system works.

(3) Battery electricity quantity display: there are 10 LED lights to shown the battery electricity quantity. When the truck gets electricity, the 10 LED lights are on when the battery is full. The LED lights reduces with the reducing of battery electricity quantity during discharging. When the 10 LED lights are off, the fault reminder  and battery minimum electricity quantity reminder  will flicker at the same time, at this time, the travel speed will slow down and lifting can not be realized, charge the battery in time.



2) Key switch

OFF----the switch is off and at this time the key can be taken out or inserted.

ON----The electric control return circuit is open and the running preparation is finished after the liquid crystal display flicker four times.

- For your safety, when operating on electric parts, please disconnect plugs. The main return circuit still has voltage even the key is off.



WARNING:

- Turn the key off and take it out before leaving the truck.
- When carrying out the following operations a) and b), the safe return circuit of the truck works. The truck is not allowed to work under such condition. Carry out reset methods.

a) When the key is ON, forward and backward switch are operated. (Operate in other gears except neutral gear).

b) When the key is ON, disconnect or connect battery plug.

Reset methods:

For a) :Put gears shifting switch in neutral position and switch the key to ON position after switch it to OFF position.

For b): turn the key to OFF position and disconnect the plug. Then turn to the ON position.

3) Acceleration knob

Step on the acceleration pedal, the integrated knob 1 is acceleration knob. Push the integrated knob forward and the truck travels towards fork leading direction; step on the brake pedal, push the knob towards the truck frame direction and the truck travels towards fork trailing direction.

4) Steering wheel

When travelling, operate through grasping the steering wheel handle with left hand.

When travelling, grasp the steering wheel handle all the time.

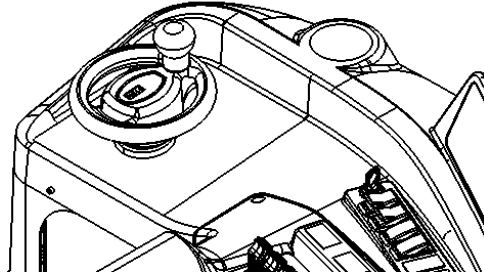

! CAUTION:

- Electric powered steering is installed on the truck. it begins working when powered steering rotates steering wheel when the key switch is ON.

! CAUTION:

Pay attention to the following when lifting and lowering, tilting , front reaching and side shifting:

- Operate in operating position;
- Make sure of the safety around.

5) Lifting thumb switch 2

There is lifting operation button 2 on integrated knob. Pull it upward and the fork will lift up ; push it downward and the fork will lower down. Proper operation speed will be realized with certain tilting angle of knob.

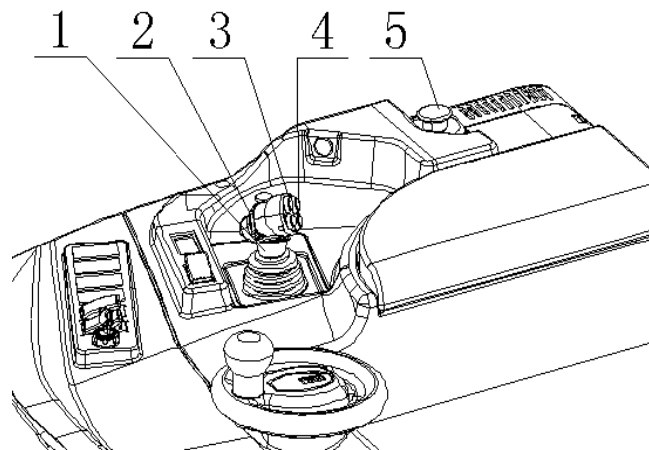

6) Front reaching thumb switch 3

There is front reaching button 3 on integrated knob. Pull it along the axis obliquely upward and the fork will reach out; pull it along the axis obliquely downward and the fork will retract back.

Proper operation speed will be realized with certain tilting angle of knob.

7) Tilting thumb switch

There is side-shifting button 5 on the integrated knob, pull it along the axis obliquely to the right and the fork will shift to the right; pull it along the axis obliquely to the left and the fork will shift to the left.

Proper operation speed will be realized with certain tilting angle of knob.

8) Side shifting thumb switch 4

Pull the switch back and the fork shifts to left; push the switch forward, the fork shifts to right.

Proper working speed can be achieved through adjusting the tilting angle of operating lever.

9) Emergency button 5

Press the emergency button and electric control system is power off.



WARNING:

- It is very dangerous to touch electric parts with hand. So disconnect the battery after the button is pressed.
- Operate after the key is turn off except for emergency. When connecting battery plug, make sure the key is on OFF position.

10) Overhead guard



CAUTION:

- The overhead guard is kind of import device to protect drivers in case of objects falling from overhead.
- When the overhead guard is loose, removed or modified, serious accident

may occur.

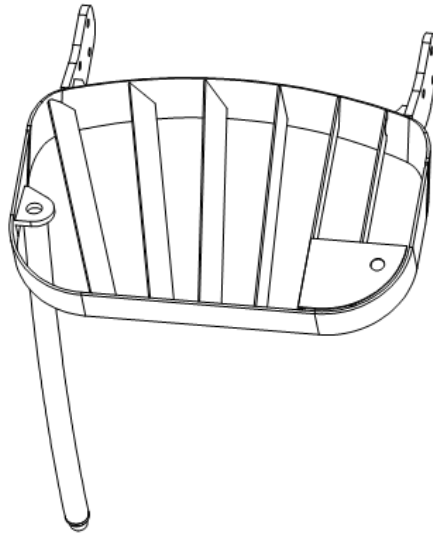

11) Fork stopper



- According to the principle that the center of the object's gravity must be consistent with the truck's center, so the fork arm should be adjusted to have equal space. After is it adjusted, be sure that the fork arm stopper is fixed to avoid the fork arm moved.
- Lean against the load backrest when adjusting the fork arm with foot. Never adjust with hand.

After loosing the fork arm stopper, the fork arm can be adjusted. We should adjust it according to the object size.

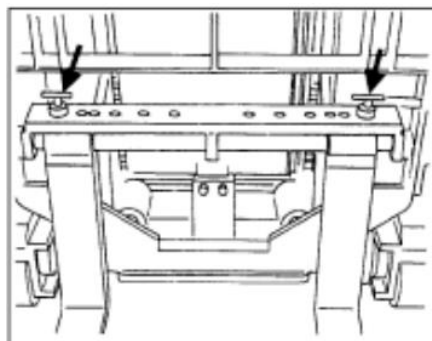

12) Hydraulic oil tank

There is oil adding port, oil draining port and oil return port. Besides there is hydraulic dipstick in oil adding cover. Check the oil level when the mast is lowered

completely and the mast seat is retracted. If the oil level is under the min. mark, add hydraulic oil.

1. Oil draining plug
2. Magnet
3. Return oil filter
4. Oil tank install plate
5. Box
6. Line card
7. Oil suction pipe
8. Oil return pipe
9. Ventilation cap
10. Cover
11. Bolt
12. Combined washer
13. Cover gasket

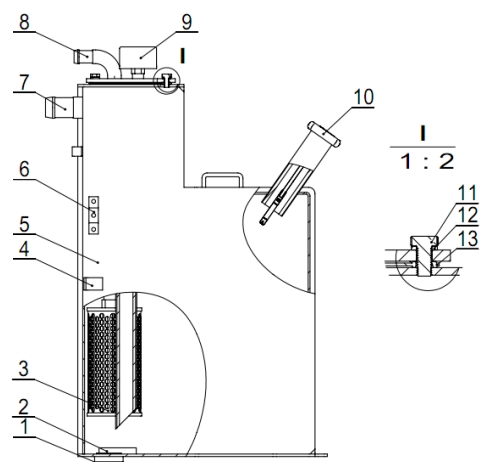

13) Battery plug



CAUTION:

- **It is dangerous when touch the inner electric parts, so you must disconnect the battery plug.**
- **The main electric loop can bear pressure even if the switch key is on off position.**
- **Never disconnect the battery plug unless it is necessary. Or you can not steering.**

The battery plug is used to connect or disconnect the battery with the electric equipment.



NOTE:

- **When disconnecting the battery plug, please turn off the key switch and**

press the emergency button.

- **When connecting the battery plug, make sure the key switch is on OFF position.**

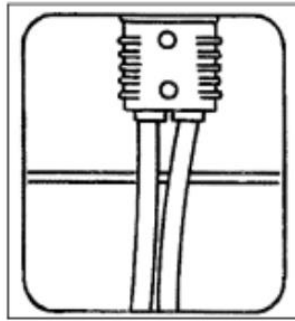

III. Operation of the truck

To keep the truck in good performance, use safely and working economically, please follow the notes below.

1. Notes on new truck usage

Though the truck has experienced thoroughly adjust and test before delivery, the truck need moderate operation in the first month (200 hours) until all parts of the truck have full running-in time.

If the new truck works at bad environment at very first, the service life of the truck will be shortened and the performance will experience bad impact.

! CAUTION:

Pay attention to the following when the truck is run-in:

- **Do not operate the truck when the truck is heavy loaded or travelling with high speed;**
- **The operation shall be smooth, avoiding emergency gear shifting, emergency braking, sharp turning and sudden acceleration;**
- **During the running in period or after replacing the new brake friction plate, the friction plate shall be fully run in to achieve the best braking effect.**

2. Relationship between load and stability of truck

The truck balances the rear weight and load with the front wheel as the supporting point. So to keep the balance, take care of the load's barycenter.

When it is overloaded, the rear wheel will lift off, and the truck will overturn in forward. Further more, the more the load's barycenter towards to the fork arm, the more heavily the load is. And so the relative goods' weight should be reduced.

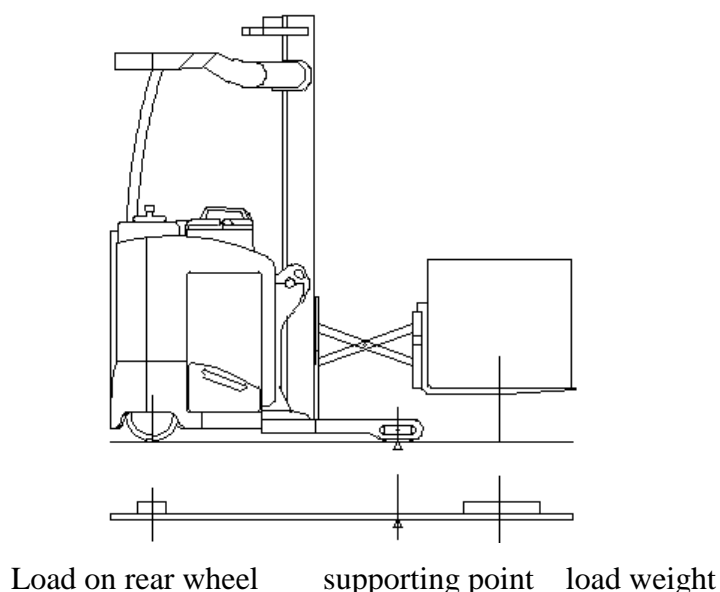

3. Load center and load chart



- **When handling load, lift the load 5-10cm higher than the truck. Draw back the fork and tilt back completely.**

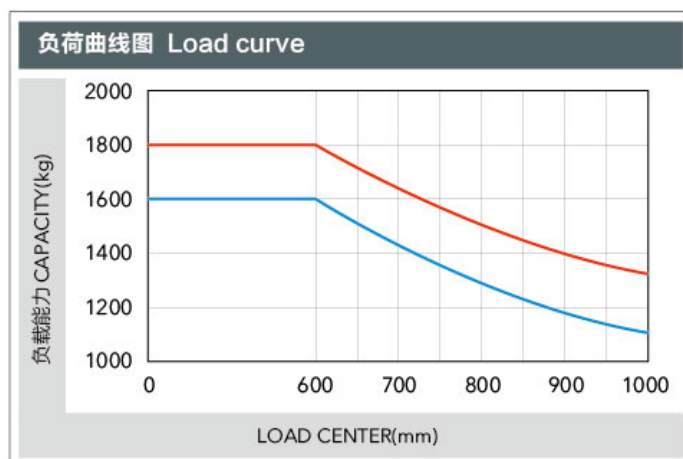

The distance between the fork arm roots and the goods center is load center. For example, the figure above shows the relationship between the load center and load capacity of 1.6t truck and 1.8t truck. The capacity chart is nailed on the truck. Please refer the one on the truck.

4. Truck stability

The state standard ordered the stability of the truck. When it reaches the condition, it is stable. But it can not keep stable on any condition.

The following list reasonable condition:

- a) The work ground is smoothness and firmness.
- b) Driving in standard load or unload state.
- c) Make the fork arm be horizontal when picking up or unload goods. Do not tilt forward unless it is necessary. Lift up slowly.

To be safety, it is necessary to keep the truck in good condition.



- **When driving without load, lift the fork 30cm above the ground and tilt the**

mast to the max. position.

- **When driving with load, refer to capacity chart. Lift the fork 30cm above the ground and tilt the fork to the max. position.**

5. Transporting of the truck



CAUTION:

When transporting with lorry:

- **Wedge the four wheels and fix the truck with rope to prevent the truck from moving.**
- **When load up, unload or drive on road, pay attention to its overall length, overall width and overall height and so on. remember to obey correlative law.**

6. Note on get onto or get out of the lorry



CAUTION:

Never steering or move transverse in connecting board to prevent any dangerous.

- Use connecting board with enough width, length and intensity.
- Apply the parking brake of the lorry and wedge up its wheels.
- Be sure the connecting board fixed in the center of the lorry. Make sure there is no grease on the connecting board.
- Keep the right and left side of the connecting board at the same height for convenient of getting on and out.
- When getting on, travel backward to make the right and left tyre land at the same time.



CAUTION:

When sling the truck:

- Only qualified people are allowed to sling the truck.
- Hook the rope at the appointed position of the truck.

- All rope should have enough strength.
- The knock-down parts of the truck have its appointed sling position also.

7. Operation of the truck

(1) Start the truck



CAUTION:

- **When starting the truck (turn on the key switch), stand rightly in the cab.**
 - **Be sure there is no one around.**
- Turn on the key switch. (The meter begins working.)
 - Hold the steering wheel knob.
 - Lift the fork to be 30cm above the ground.
 - Draw back the working device.
 - Tilt the working device backward.

(2) Travelling



CAUTION:

- **Ensure the safety around with eye and sound the horn before driving.**
 - **Slow down in the following condition:**
- in sharp turning;
 - in narrow road
 - on bad road
 - when near the goods or obstacle
- When travelling backward, it is dangerous to depend on back view mirror only.

Face backward and travel after a direct check of the backward.

Operate on the forward and backward switch. Step on the acceleration pedal and the truck begins to travel. Travel speed increase with the decrease of the pedal angle.

(3) Steering



CAUTION:

When steering, the rear part of the truck rotates to the outside greatly.

The truck is different from automobile and its steering wheel is rear wheel, so when steering, the rear part of the truck rotates to the outside greatly. Slow down when steering and steer a little earlier than automobile.

- a) Hold the steering wheel knob with left hand;
- b) Operate the lifting system lever with right hand.

(4) Parking the truck or for a while

Loose the electric pedal and slow down. Step on the brake pedal and stop.

Park the truck in a place where does not disturb traffic. when parking, do as followed:

- a) Draw back the working device;
- b) Tilt the fork forward;
- c) Lower the fork to the ground;
- d) Turn off the key switch and keep it well;
- e) Take care to get off the truck.



CAUTION:

Safety parking

- The parking place should be as wide and flat possible. When unloaded truck has to park on a slope, the mast side should face downward. Wedge the wheels.
- When parking at a safe place or appointed place, pay attention to the signs and signals.
- Park at a solid ground and take care to prevent it from slipping.
- When the fork can not be lowered because of fault, hang a piece of cloth on it and face toward to the direction that people or any other truck can not pass.
- Take care of the wet road and easy-collapse road.
- Lower the fork until the truck is stopped completely. It is very dangerous to lower during travelling.
- Do not jump of the truck.

- Get out of the truck from the direction facing to the truck direction.

(5) Ground condition



CAUTION:

- Be careful when travelling on uneven road.
- When get across a railway, park for a while to be sure its safety.
- Bypass any obstacle (monument, wood or scraggy place).
- Be careful and driving slowly if you can not bypass the obstacle, drive in the place where the obstacle can not meet the truck undersurface.

According truck structure, the limits of driving beyond the following list.

(6) Move out the battery and place it well.

Note:

- Install or move out the battery on level ground and surface without barriers.
- Lower the fork to 100-300mm and make sure there is no goods on the fork.
- Turn off the key, lower the fork, disconnect the battery when check, maintain or change the battery.
- When installing the battery, make sure the cables are not distorted or clamped.
 - Turn off the key switch and disconnect the battery. Check and make sure all controls in neutral position.
 - Remove the battery baffle.
 - Install the battery with battery side pull dolly or other auxiliary device to make sure height conformity between battery installation and battery rolling device.

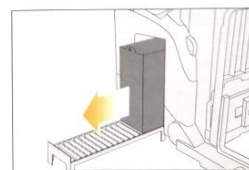
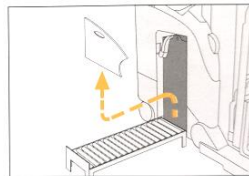

8. Battery usage

(1) Usage notes



CAUTION:

- Select proper battery charger and do according to BATTERY SERVICE MANUAL.
- When changing a battery, do according to the following orders:
 - a) Disconnect the battery plug.
 - b) Move out the battery.
 - c) Be care not to hit the truck body when slinging the battery out.
 - d) Connect the battery plug after the battery is well placed.
- When replacing the battery, make sure the battery match the truck. if the battery does not match the truck, it will reduce the truck's use time or the truck will be overturned in driving.

When the battery has worked for a cycle and the power of the battery is exhausted, replace the battery with a fully charged battery. Charge the battery in time.

(2) Notes when handling battery



CAUTION:

- Proper connection: during charging or operation, connect the positive pole and negative pole properly or over high temperature, burn, smoke and explosion may occur.
- It is prohibited to put metal object on battery because short circuit may occur because of the connection of positive pole and negative pole.
- Be care with electric shock. When maintaining and servicing, do not connect electric parts of the battery or serious burn may occur.
- Wear protective suits. When servicing the battery, wear glasses, rubber glove and rubber shoes.
- No disassembling, do not take out the electrolyte from the battery; do not

disassemble the battery; do not repair the battery unless authorized.

- Do not over discharge. Do not use the truck until it can not move again or it will reduce the battery service lift. The battery should be charged when the battery indicator gives an alarm.
- Cover the battery's cover to avoid the electrolyte leakage or spill. The electrolyte can not add too much. Over flowed electrolyte will cause creepage.
- Refuse water. The battery can not exposed in rain or seawater. It can damage the battery or cause fire.
- Cleaning. Do not clean the truck with the battery, or the acid will damage the truck.
- The electrolyte is harmful. The electrolyte is made up of dilute vitriol. Be care when handling the battery. Eyesight may be loosed or burnt
- Dealing with abandoned battery. Contact with our sale department when dealing with abandoned battery.
- Abnormal phenomena of the battery. when the battery is smelly, the electrolyte is dirty, the temperature of the battery is over high, the electrolyte decrement is too fast, contact with our sale department.

(3) Maintain or service the battery

CAUTION:

- Keep the electrolyte in reasonable quantity or it will heat or burn the battery. when the electrolyte is shortage, it will reduce the battery service lift. Check the electrolyte every week.
- Add pure water or distilled water, according to the BATTERY MAINTENANCE MANUAL.
- Overcharging is prohibited.
- The charging place should be well ventilated and forbidding humidity.
- It will produce excessive amounts of hydrogen while charging, so uncover the battery cover.
- Check the battery plug and the cable, be sure it is damaged.

- For battery compartment without liquid leakage hole, check if there is hydrops inside of compartment every month. If there is electrolyte spillage caused by improper adding of distilled water, please clean the hydrops in the compartment with sucker in time.

Do not charge the battery which had the following conditions:

- a) the electrode of plug is damaged;
- b) the terminal and cable are rusted.

These cause sparks, damages of burn and ignite explosions.

- Charge after turning off the key switch.
- Check for specific gravity of all cells before charging.
- Pulling out or putting on the plug should be done by holding plug itself but not cable. When cable and plug are damaged, contact with sale department of our company and replace them.
- When disconnecting the charging of battery, operate it according to the OPERATION AND SERVICE MANUAL of the charger.
- Do not pull out the plug when charging the battery, or spark may be caused.

(4) Notes when charging

 **CAUTION:**

- When charging the battery, hydrogen gas is occurred and it is very dangerous. No smoking.
- Charge the battery where is well ventilated and is not humid and away from ignite.
- During charging, electrolyte may drop on the ground, so the ground surface should endure acid and be very easy to drain.
- During charging, explosive gas is produced. It is very dangerous and do not let cigarette and other fire approach it.
- During charging, do not disconnect the battery plug, it is not only very dangerous and insufficient charging may be caused.
- During charging, turn off the key switch for safety.



NOTE:

- If the electrolyte temperature is higher than 40°C when beginning charging, stop charging for a while.
- During charging, when the electrolyte temperature exceeds 50°C, it is bad for battery service life.
- Do not charge the battery in low temperature for example, charging outside housed in the cold areas or in the refrigerator warehoused will shorten the battery service life.
- Vehicle and electrical parts can not be splashed the electrolyte. If splashed, contact with our company to take relative measures.

(5) Electrolyte usage



CAUTION:

Electrolyte us mainly rare vitriol and water, take care when dealing with it. If accidents occur, go to hospital after taking urgent measures. If not, you will injury and even lose eyesight.

- When electrolyte is splashed on your skin, wash then by a great deal of water.
- When electrolyte is splashed into your eyes, wash then by a great deal of clean water for 15 minutes.
- When electrolyte is drunk by mistake, wash your mouth with a great deal of water and then drink egg white with milk and a great deal of water. Than stay still.
- When electrolyte is splashed on clothing, take off and wash then by water and then neutralize with alkali.
- When a great of electrolyte is splashed, wash by a heavy calcium carbonate first and then wash by water.

You can go to police station, fire company and health protection place to take necessary measures according to law regulations.

9. Loading and unloading

(1) Loading

a) The distance between two forks should be as wide as possible so that the truck has a better transverse stability.

b) When the forks are inserted into pallet. The center of the load should be in the middle of the two forks.

c) Insert into the pallet parallelly.

d) Insert the fork into the pallet fully.

e) when the forks lift up the pallet and leave the ground:

- The forks lift up the pallet 5-10cm. Take care of the load stability.
- The forks lift up the pallet 30ccm.
- Tilt the mast backward for stabilizing the load and start to drive.

f) When the position of the pallet is high and the front view is poor, drive backward.

(2) Stacking

a) Slow down the travel speed when approaching the stacking area.

b) Stop the truck in front of stacking area.

c) Check for safety around the stacking area.

d) Tilt the mast and make the fork horizontal and lift the forks above the stacking position.

e) Check the stacking position and move forward and stop slowly at the proper position.

f) Operate the forward and backward switch and make the goods at the stacking position.

g) Lower the goods after the affirming the stacking position.

h) Make sure the working device is retracted back through reaching operation and be care not to catch the pallet or goods by the fork. Then travel backward after make sure the backward safety.

i) Make sure the tips of the forks are off the load and pallet, and lower the forks to the position for running (15-20cm above the floor).

i) Tilt the fork backward.



CAUTION:

- **When the goods are lifted high, never tilt the mast forward except when at the beginning of stacking.**
- **When the goods are high, the driver can not leave the truck.**

(3) Picking operation

a) Slow down the travelling speed when approaching a load to be picked up.

b) Stop the truck in front of the load (about 30cm between the load and the fork tips).

c) Make sure safety of load.

d) Tilt the forks to horizontal position and lift up to the position of pallet of carriage hole.

e) Check the proper position of inserting the forks and move forward slowly, stop the truck at a proper position.

f) Through operating the mast forward and backward, inset the forks fully to the pallet.

When it is different to insert the forks fully into the pallet: through operating the mast forward and backward, insert the forks by its 3/4 length and lift up the pallet a little (50-100mm) and lower the pallet again. and then insert the forks fully into the pallet.

g) After inserting the forks, lift up the pallet 5-10cm. then draw back the working device.

h) Check the safety of the rear area and the position of carrying load, drive the truck backward safety.

i) Lift up the pallet 5-10cm. tilt the mast backward completely and then carry the

load to its destination.

10. Vehicle storing

(1) Before storing



CAUTION

The small troubles are the causes of serious accident.

Even there is a little abnormality, report to supervisor. Do not operate it before finishing the repair.

Before storing, clean it thoroughly and perform inspection according to the following procedures. It is important for use at any time in future.

- Wipe away grease, oil, and etc adhering to the truck body with waste cloth and water if needed.
- Check the body of the truck, if there are some abnormality (concave or protruding, chap and etc.)
- Check if there is leakage.
- Apply grease, where needed.
- Check for looseness of hub nut, cylinder piston rod joint.
- Check the working of mast roller.
- Prime oil into the lift cylinders by actuating the lift cylinders at the full stroke.

(2) Daily storage

- Park the truck at a specified place and block the wheels, then charge the battery.
- Turn the key switch OFF. Operate all switches slowly 2-3 times to release oil press in the oil pipe.
- Remove the key and keep it well.

(3) Long term storage

Carry out the following items except the items in BEFORE STORING AND

DAILY STORING.

- Park the truck at a higher and hard ground taking the rainy season into consideration.
- Dismount the battery.
- Even though the truck is parked indoors, if the place is hot and humid, the battery should be kept in a dry, cool place. Change the battery once a month.
- Apply antirust to the expose parts such as cylinder rods and shafts which tends to rust.
- Cover the components such as the breather and air cleaner which may be caught with humidity.
- The truck should be operated at least once a week and moved slightly forward and backward.
- Avoid parking on soft grounds such as phalt ground in summer.

(4) Operate the truck after long term storage.

- Remove the humility proof cover.
- Remove antirust from the exposed parts.
- Discharge the gear oil of the transmission box. Change new oil.
- Discharge the foreign matter and water from hydraulic oil tank.
- Charge the battery the mount in on the truck. Connect the cables.
- Perform pre-operational check carefully.

IV. Inspection

1. Inspection prior to operate

Inspect the truck before operation so as to ensure work safety and keep truck in good performance. Common inspection methods are introduced below.



CAUTION:

- **If your truck is found to be abnormal in the inspection, stop operating and pull out the key and report to administrative person. The truck is forbidden to operate before finishing the repair.**
- **Oil leakage is the fire reason of the truck.**
- **Disconnect the battery plug when inspecting electric devices.**
- **When lifting up the fork and checking under the fork, for preventing the fork from falling down, using the wood to support between the inner mast and the ground.**
- **When checking front reach, put pallet between mast and frame to prevent from being caught.**
- **Dealing with the waste oil improperly (drain into the sewer, soil and ignition) will pollute the soil and atmosphere. This is forbidden by law.**

(1) Notes when inspecting

- a) When replacing parts, use HELI pure parts.
- b) Please use HELI pure oil and grease.
- c) When adding oil or grease, clean the oil adding mouth with brush or cloth.
- d) When checking the oil capacity, park the truck on a flat ground.
- e) The inspection method should be correct, proper and take care not to be injured.

(2) Preparation before inspection

- a) Inspection around the truck

Before getting on the truck, observe around the truck and check if the tyres and

the body are abnormal.

b) The status of the truck

Check if it inclines to one side. When inclining, the tyres or chassis may have some fault, contact HELI specified service point.

c) Check the parking ground

Check if there is leaked oil on the parking ground. If there is any fault, contact with HELI specified service point.

(3) Inspection items

a) Where is abnormal last time



CAUTION:

- Do not operate the truck until it is repaired.
- Check if the abnormal found last time is completely repaired.

b) Inspection of electric wires

Check if battery wire, charge wire, other wire and battery plug are loose and damaged.

c) Inspection of electrolyte level

Check if the electrolyte level is at the prescriptive position.

d) Inspection of battery lock device

Check if the battery is locked by the hook on the truck. if it is not hooked, the battery will shake.

e) Inspection of backrest



CAUTION:

- Do not disassemble or modify backrest, or the load will fall down. This will cause an unimaginable result. Check if the bolts and nuts of backrest are tightened.

f) Inspection of fork

Check if the fork fixed pin is locked and check if forks are crack and bend.

g) Inspection of front wheel(supporting wheel)

Check if the front wheels are wear, crack and damaged.

h) Inspection of pipelines and cylinders

Check if pipelines and cylinders (lift cylinder, tilt cylinder , reach cylinder) leak.

i) Inspection of driving wheel

Check if driving wheels are wear, crack and damaged.

j) Inspection of auxiliary wheels

check if the auxiliary wheels are wear, crack and damaged.

k) Inspection of hydraulic oil

Check if hydraulic oil level is in a prescriptive range.

Open the cover and pull out the oil dipstick. Clean the dipstick with clean cloth and insert into oil tank again. check the oil level, it should stay between “H” and “L”.



NOTE:

- **Check the oil level on flat ground.**

l) Inspection of brake pedal

Press and depress the brake pedal to check if the return of brake pedal is normal.

m) Inspection on steering clearance

Turn the steering wheel clockwise and anti-clockwise slightly and check if there is enough steering clearance. Check if the steering wheel is loose up and down.

Steering clearance: 20~30mm.

n) Inspection of meter

When the key is ON, make sure the meter is normal.

o) Inspection of horn

Press the horn check if it sounds.

p) Inspection of all levers

Operate all levers 2or 3 times and check if fork and mast works smoothly and if there is abnormal sound.

Check if knobs are loose.



NOTE:

- **Make the cylinders work before operating several times so as to lubricate the oil seal and bearings completely. Make the truck ready for operate.**

q) Inspection of the tension of lift chains



CAUTION:

- **Make sure the lift chains are equivalent in tension. If not, there is a danger of tip over even if goods are loaded correctly.**
- **Lift up forks 50cm. Check if the chains are equivalent in tension. If not, adjust fixing bolt. After adjusting, tighten the lock nut.**

r) Inspection of overhead guard

Check if the overhead guard fixing bolts and nuts are loose.

s) Inspection of steering wheel

Turn the steering clockwise and anti-clockwise lightly and check to see if there is abnormal.

2. Periodic inspection

It is very necessary to do periodic inspection in order to operate truck safely in good condition.

Using a fault will cause serious accident. Inspection and maintenance are ignored usually. Finding the fault early and solving it timely will do good to develop the truck's working ability, improve productivity, extent the truck's using life and bring economic benefits.

Except simple inspections before operation such as oil adding, clean filter and so on, please carry out complicated inspection in HELI specified service point because professional knowledge and special tools and equipment are needed. Or serious accident may occur.

Hours shown below are based on 200 hour operation per month.



CAUTION:

- Please read the contents described in this chapter before inspection.

(1) Replace the safety parts regularly

It is very important to make precautionary maintenance for operating safety. Especially the following safety parts must be replaced periodically because they are related to truck and operator safety. What is more, they are easy to be damaged. Common maintenance can hardly make sure whether they are beyond the service life. The quality guarantee does not include the safety parts.



NOTE:

- The safety parts periodic replacement is different from remedy of the trouble.

Safety parts name	Year
High pressure oil pipe for lifting	1-2
Lifting chain	2-4

(2) Weekly inspection (50h)

Inspect the following items in addition to the inspection prior to operation:

- Cleaning battery
- Measuring and adjusting of battery electrolyte gravity and temperature
- Adding grease to the reaching fork bracket

The inspection prior to operation and weekly servicing can be done by the user.

It depends on the user himself.

In order to operate the truck safely and efficiently, please check it carefully.

a) Cleaning battery

Keep the top of the battery and the connecting area clean and dry.



CAUTION:

Please clean the battery with a dry cotton cloth. In order to prevent static

electricity and explosion, please do not clean it with a wet cloth.

b) Adding grease to the reaching fork bracket

Add a thin-layer grease to the center of both left and right reaching fork bracket groove's inside surface.

(3) Monthly inspection (200h)

Inspect the following items in addition to the inspection prior to operation and weekly inspection:

- Battery charging;
- Check whether the battery's plug is damaged or loosing;
- Check whether the wire is damaged or color changed;
- Check whether connecting points are burnt;
- Check the forward and backward switches;
- Check whether the braking pedal is loose;
- Check the steering clearance, operating state and whether it jolt when steering;
- Check the steering chain's tension and adding grease;
- Adding grease;
- Check the drive device oil quantity and cleanness;
- Check the drive wheel and support wheel wear and damage condition ;
- Check the wheel fix nut and bolts;
- Check whether the hub bearing shakes or has abnormal noise. Add grease;
- Check the rear wheel working condition;
- Check the hydraulic oil quantity and cleanness;
- Check the oil pump working condition and whether it leaks;
- Check whether the control valve operating knob shake or loose;
- Check the overflow working condition ;
- Check the mast working condition and whether it is damaged or shakes;
- Check the condition of pulley block;

- Check the roller (main roller, side roller and brake wheel) working condition;
- Check the oil cylinder (lifting, tilting and reaching) working condition ;
- Lubricate the lifting chain and adjust its tension;
- Check whether the fork is cracked or deformed;
- Check whether the overhead guard and backrest are loose, cracked or deformed;
- Check whether the frame support wheel is damaged or deformed;
- Check whether the connecting bolts of the frame and mast are loose;
- Tighten the main studs and nuts.

The monthly inspection needs more technology and special tools and the adjusting and replacement are complex.

Inspection, adjusting and replacement should be done by HELI specified service point according to HELI periodic inspection service contact.

a) Lubricate the lifting chain

Lubricate lifting chain with engine oil. Pay attention to the following item in order to fully lubricate pin and link joint.

- Add oil when the chain is loosing.
- Lift and lower the mast fully for at least 10 times after adding oil.

NOTE:

In order to avoid the salt's corruption, please wash the truck with water after typhoon or great wind and then add grease especially near the coast and haven.

b) The slipping block on top of the mast

Add grease to the slipping block follow the arrow direction.

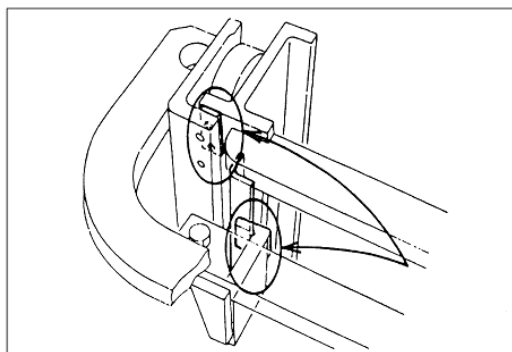



WARNING:

- **Put hands and feet on the connecting area when climb the mast. Do not put hands and feet between the outer mast and inner mast for it can be moved accidentally and will lead to a serious accident.**

(4) Inspection every three month (600h)

Inspect the following items in addition to the inspection prior to operation, weekly inspection and monthly inspection.

- Check if the connecting point of the motor(pump, drive, steering) connecting terminal is burnt;
- Change the gear oil of the drive unit (new truck) ;
- Check the insulation condition of electric parts ;
- Check the voltage relay of the charger's operation and adjust the voltage;
- Check the electric timing of the charger's operation and adjust the time;
- Check the clearance between the brake disc and friction disc;

Inspection, adjusting and replacement should be done by HELI specified service point according to HELI periodic inspection service contact.

(5) Semiannually (1200h) inspection

Inspect the following items in addition to the inspection prior to operation, weekly inspection, monthly inspection and every three monthly inspection:

- Check the connecting piece's surface of the battery plug and spring;
- Adjust the contactor 's connecting point and clearance;
- Clean the drive motor ;
- Adjust the unstable current of the drive motor ;
- Change the hydraulic oil;
- Change the gear of the transmission unit;
- Clean the hydraulic oil suction filter;
- Adjust the over flow pressure of the over flow valve ;

- Tighten the connecting bolts between the frame and mast ;
- Tighten the main bolts of the frame and mast.

Inspection, adjusting and replacement should be done by HELI specified service point according to HELI periodic inspection service contact.

(6) Annually inspection (2400h)

Inspect the following items in addition to the inspection prior to operation, weekly inspection, monthly inspection, every three monthly inspection and annually inspection:

- Measure the natural downfall distance of the lift cylinder ;
- Check if the friction disc of the brake is worn and shakes;
- Check if the R area of the fork is cracked.

(Color filter inspection)

The annually inspection must be carried out as mentioned above.

In addition, this inspection must be carried out by the approved service and please accomplish inspection at the HELI specified service point.

(7) Periodic inspection time table

The table is based on standard working time and condition. When the working time and condition are different, please do the inspection, adjustment and replacement earlier (● means replacement or replenish)

a) Electric device								
Item	Content	Check before operation	Weekly	Monthly	Every three-month	Semiannually	Annually	
			50h	200h	600h	1200h	2400h	
Battery	Surface cleanness	Clean		<input type="radio"/>	<input type="radio"/>	<input type="radio"/>	<input type="radio"/>	<input type="radio"/>
	Electrolyte quantity	Check and replenish	<input type="radio"/>	<input type="radio"/>	<input type="radio"/>	<input type="radio"/>	<input type="radio"/>	<input type="radio"/>
	Gravity	Measure and adjust		<input type="radio"/>	<input type="radio"/>	<input type="radio"/>	<input type="radio"/>	<input type="radio"/>
	Equal charging				<input type="radio"/>	<input type="radio"/>	<input type="radio"/>	<input type="radio"/>
	Insulation status	Measure				<input type="radio"/>	<input type="radio"/>	<input type="radio"/>
Controller	Surface cleanness	Clean			<input type="radio"/>	<input type="radio"/>	<input type="radio"/>	<input type="radio"/>
	Electric contact erode	Inspect			<input type="radio"/>	<input type="radio"/>	<input type="radio"/>	<input type="radio"/>
	Electric contact clearance	Inspect and adjust						<input type="radio"/>
	Insulation status	Measure				<input type="radio"/>	<input type="radio"/>	<input type="radio"/>
	The joint loosening	Clean			<input type="radio"/>	<input type="radio"/>	<input type="radio"/>	<input type="radio"/>
Motor	Operation condition	Inspect and adjust				<input type="radio"/>	<input type="radio"/>	<input type="radio"/>

	Abnormal noise	Inspect				○	○	○
	Unstable current (drive motor)	Measure and adjust					○	○
	Insulation condition	Measure				○	○	○
	cleanness	Clean					○	○
Wires, binding post, plugs and sockets	Loose	Inspect and tighten	○	○	○	○	○	○
	Spring condition of contacting piece of the battery socket	Inspect					○	○
	Damage	Inspect	○	○	○	○	○	○
	Color	Inspect			○	○	○	○
	Battery socket contact surface erode	Inspect					○	○
Others	Accelerator condition	Inspect and adjust			○	○	○	○
	Horn sound	Inspect, clean and change	○	○	○	○	○	○
	Attachments (lights) function	Inspect	○	○	○	○	○	○

b) Brake, steering and travelling device								
Item	Content	Check before operation	Weekly	Monthly	Every three-month	Semiannually	Annually	
			50h	200h	600h	1200h	2400h	
Brake	Brake effect	Inspect	○	○	○	○	○	○
	Brake clearance	Inspect and adjust	○	○	○	○	○	○
	Friction disc wear	Change				●	●	
Steering	Abnormal noise	Inspect	○		○	●	●	●
	Approaching switch clearance	Inspect and adjust			○	○	○	○
Wheel	Abnormal wear	Abnormal wear	○	○	○	○	○	○
	Installation condition	Inspect and tighten	○		○	○	○	○
	Wheel bearing lubrication	Inspect and change	○		●	●	●	●
Gear box	Leakage	Inspect	○	○	○	○	○	○
	Oil level	Inspect and change	○				●	●
	Abnormal noise	Inspect	○		○	○	○	○

c) Lifting system								
Item	Content	Check before operation	Weekly	Monthly	Every three-month	Semiannually	Annually	
			50h	200h	600h	1200h	2400h	
Hydraulic oil tank	Oil level and cleanness	Change and inspect	○	○	○	○	●	●
	Oil suction filter	Clean					○	○
Lifting chain	Tension	Inspect and adjust	○	○	○	○	○	○
	Lubrication condition	Add oil			○	○	○	
	Chain replacement	Change						● (2-4years)
Hydraulic pump	Work condition, leakage, damage and installation condition	Inspect	○	○	○	○	○	○
Control valve	Work condition, leakage, damage and installation condition	Inspect	○	○	○	○	○	○
	Overflow valve work condition	Measure pressure			○	○	○	○

	Operating lever work condition , jolt and damage condition	Inspect	○	○	○	○	○	○
	Inching switch work condition , jolt and damage condition	Inspect			○	○	○	○
Hydraulic pipeline	Leakage, jolt, loose, deformation and damage condition	Tighten	○	○	○	○	○	○
	High pressure pipeline replacement	Change						● (1-2year)
Mast	Working condition, crack, curve or jolt	Inspect	○	○	○	○	○	○
	Chain wheel work condition, crack, jolt	Inspect and tighten			○	○	○	○
	Roller work condition, jolt, damage or loosing	Inspect ,tighten and change			○	○	○	○
	Fork bracket condition, jolt, crack or curve	Inspect			○	○	○	○

All oil cylinders	Work condition, leakage	Inspect	○	○	○	○	○	○
	Piston rod, screwed part and end are damaged	Inspect	○	○	○	○	○	○
	Natural decline distance	Measure						○
Fork	R part crack condition	Color filter						○
	Curve, crack and wear condition	Inspect	○	○	○	○	○	○
	Fix pin curve, crack, wear and damage condition	Inspect	○	○	○	○	○	○
Backrest (optional)	Crack, deform, damage condition	Inspect	○	○	○	○	○	○
	Fixing bolt loose condition	Inspect and tighten	○	○	○	○	○	○

d) Truck body and others								
Items		Content	Check before operation	Weekly	Monthly	Every three-month	Semiannually	Annually
				50h	200h	600h	1200h	2400h
Overhead guard	Crack, deform condition	Inspect	○	○	○	○	○	○
	Fixing bolt loose	Inspect and tighten	○	○	○	○	○	○
Support plate	Crack, damage, deform condition	Inspect	○	○	○	○	○	○
	Oil adding condition	Add oil			○	○	○	○
Truck body	Bolts loose	Inspect and tighten			○ (initial time)		○	○
	Crack, damage, deform condition	Inspect	○	○	○	○	○	○
	Adjustment of clearance between the two articulated sides of drive axle	Inspect and adjust		○	○	○	○	○
	Bearing connecting the drive axle pivot	Inspect, change and lubricate			○	●	●	●

Working device	Work condition, leakage, damage and deform condition	Inspect			○	○	○	○
	Installation condition	Inspect			○	○	○	○
	Pin axle connecting inner and outer fork plates	Inspect, change and lubricate	○	○	●	●	●	●
	Bearing of tilting cylinder pivot	Inspect, change and lubricate	○	○	●	●	●	●
	Pivot of front reaching cylinder	Inspect, change and lubricate	○	○	●	●	●	●
	Guide rail of attachment steel channel	Inspect, change and lubricate		○	●	●	●	●
Others	Abnormal before	Inspect	○	○	○	○	○	○

HELI
LIFTING THE FUTURE

ADD:NO.668 Fangxing Street,Economical Development Zone,Hefei ,P.R.China
TEL:(86 551)63689000 FAX:(86 551)63689666
400 SERVICE: 4001-600761 WEBSITE:<http://www.helichina.com>

S274-3:2020

FREE SERVICE HOTLINE
4001 600 761

heli copyright

0707:6-4/76