

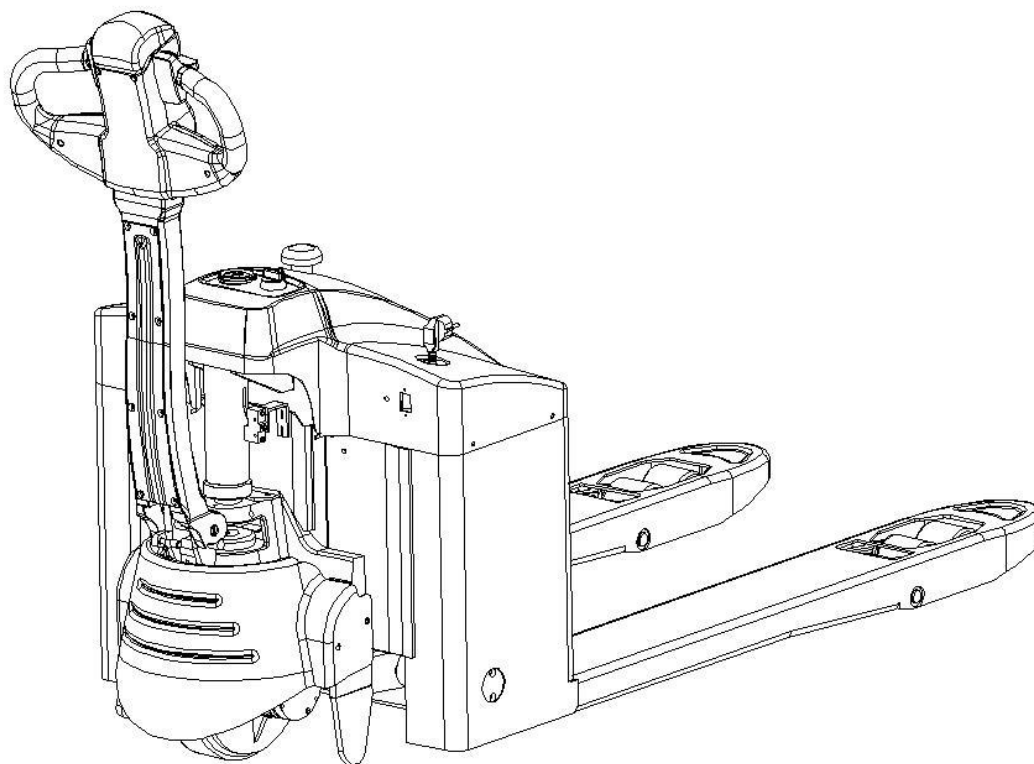

Operation and Maintenance manual

CBD15-170G

Electric Stacker Trucks



Warning! Please read this manual before using.

Warning! Operator should have skillful ability to use this truck and compliance safety rules.

Ningbo Lida Logistics Equipment Co., Ltd.

Contents

1. General introduction.....	4
1.1 Using scope.....	4
1.2 Vehicle components.....	5
1.2.1 Handle operation.....	5
1.2.2 Key switch	6
1.2.3 Battery discharge indicator.....	6
1.2.4 Emergency parking.....	6
1.3 Standard configuration of technical data	7
1.3.1 Performance Data.....	7
1.3.2 Dimensions Data.....	7
1.3.3 Weights.....	8
1.3.4 Battery.....	8
1.3.5 Tyres.....	8
1.4 Data Plates.....	9
2. Initial use.....	9
3. Battery - Recharging,Replacement.....	10
3.1 Safety Regulations for Handling Acid Batteries.....	10
3.1.1 Fire protection.....	10
3.1.2 Battery maintenance.....	10
3.2 Battery and charger Types.....	10
3.3 Charging.....	10
3.3.1 Charging.....	10
3.3.2 Finish of charging.....	11
3.4 Battery Removal and Installation.....	11
3.4.1 Removing the battery.....	11
3.4.2 Installment of battery.....	11
4. Industrial Truck Operation.....	12
4.1 Safety Regulations for Truck Operation	12
4.2 Driving.....	13
4.3 Steering	13
4.4 Braking.....	13
4.4.1 Service brake.....	13
4.4.2 Inversion braking.....	13

4.4.3 Regenerative braking.....	13
4.5 Parking vehicles safely.....	13
5. Maintenance and repair.....	14
5.1 Operation safety and environmental protection	14
5.2 Safety regulation for maintenance	14
5.2.1 Service person.....	14
5.2.2 Lifting and jacking equipment	14
5.2.3 Clean operation	14
5.2.4 Operation to the electrical system	15
5.2.5 Regulation parameters	15
5.2.6 Vehicle tire	15
5.2.7 High pressure hose for hydraulic system	15
5.3 Maintenance and inspection	15
5.3.1 Maintenance checklist.....	17
5.3.2 lubrication maintenance.....	18
5.3.3 Maintenance instructions.....	18
5.3.4 Disuse and storage.....	20
5.3.5 Safety inspection on the vehicle regularly or in case of abnormal conditions.....	20

1. General introduction

1.1 Using scope

The pallet truck is permitted only in accordance with this instruction manual.

The pallet truck described in this manual is a walking on pallet truck with self-propelled control, with the function of controlling the height lifting by electric operation. This truck is designed for lifting, descending and carrying loads.

This manual provide vehicles related technical characteristics, structure, vehicle parts, operation and maintenance. Operators and serviceman should follow the correct operation and maintenance. Any accidents caused by unreasonable operation of users take charge by itself, our company will not assume any responsibility, For unrelated users, please contact my sales companies and related personnel.

Improper use can lead to personal injury or machine damage. **The operator should use properly and the vehicle is operated only by trained and authorized person.**

The truck should be used on a firm, flat, well-formed surface and suitable road. Generally in +5°C to +40°C room temperature environment under the indoor use.

Rated load capacity are marked on capacity labels and nameplates, and operators must pay attention to these warning labels and safety instructions. Any modify that may affect the rated load, stability or safe operation of the vehicle should have written approval from the vehicle's originator or its authorized manufacturer. It include such as increased braking, steering, visibility and removable attachments. After a modification or change is approved by the manufacturer or its successor, the capacity nameplate, label, identification mark, operation and maintenance manual shall be changed accordingly. Failure to follow these instructions will result in loss of warranty.

Our company's business policy is to continuously improve the product. If the specification isn't consistent with the actual product due to product parameters change. please connect with the company in time, please understand.

The vehicle data and structure introduced in this manual shall not be used as the basis for product acceptance.

1.2 Vehicle components

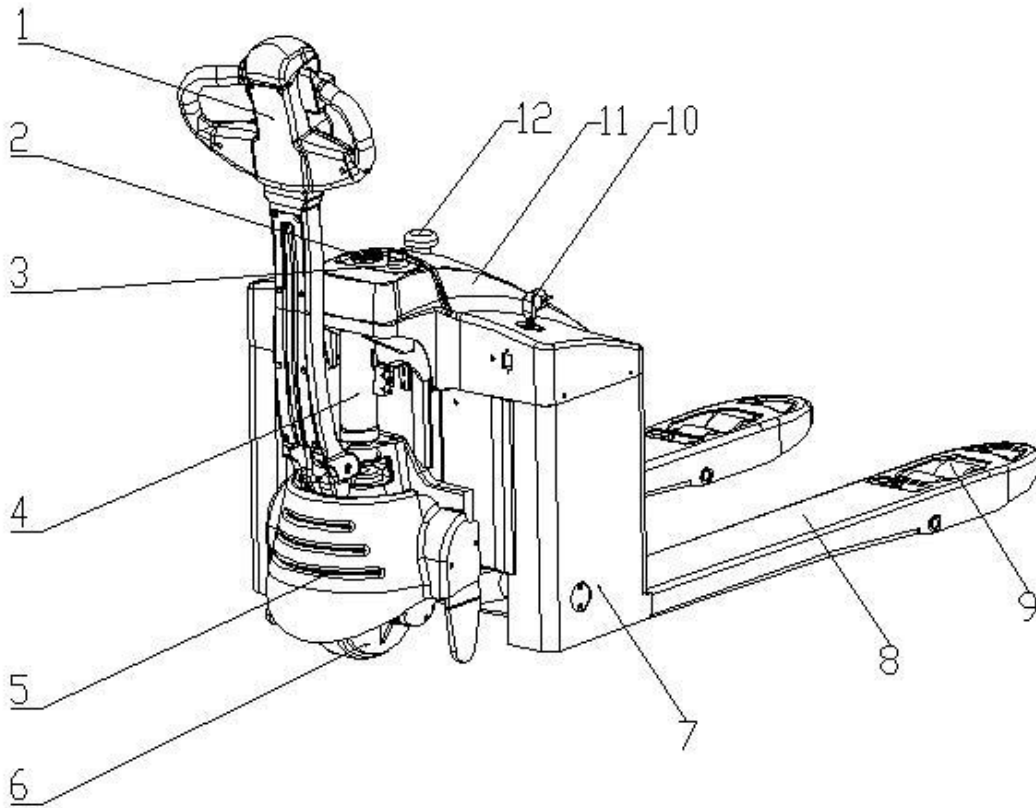

Serial number	Name	Serial number	Name
1	Operating handle	7	Frame
2	Battery discharge indicator	8	Pallet fork
3	Key switch	9	Load bearing wheel assembly
4	Lifting cylinder	10	Changing cable
5	Cover plate	11	Battery cover
6	Drive wheel assembly	12	Emergency button

1.2.1 Handle operation

Serial number	Name	Function
1	Emergency reverse button	Protect driver function switch
2	Traveling switch	Control driving direction and speed
3	The horn button	Sound the alarm
4	Rising button	Lifting load
5	Decline button	Descending load

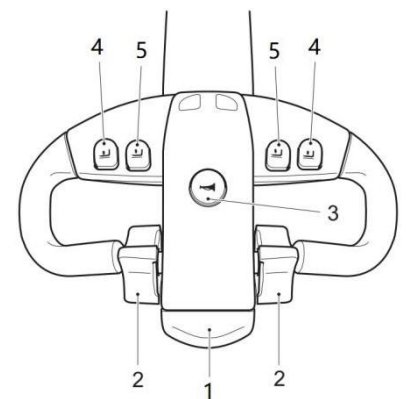

1.2.2 Key switch

Screw the key to the "ON" position, turn on the vehicle power.

Screw the key to the "OFF" position, turn off the vehicle power.

In case of vehicle failure, please turn the key switch to the "OFF" position and drag the vehicle to a safe place before maintenance.

Before leaving the vehicle, unplug the switch lock key to ensure that the vehicle will not start accidentally.

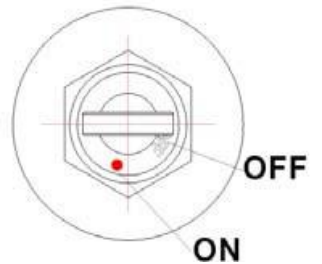

1.2.3 Battery discharge indicator

The battery discharge status is indicated by 10 LEDs on the battery discharge indicator/hour meter. 5 green, 3 yellow and 2 red LEDs are provided. One LED corresponds to 10% of the battery capacity.

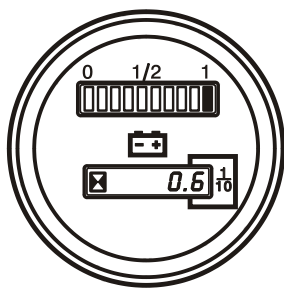

Fully charged

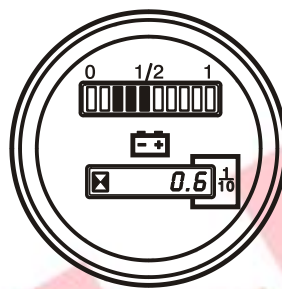

Recharge necessary

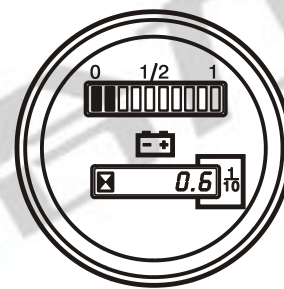

Charge status low

If a red LED flashes, this indicates that the truck is in the energy reserve mode (30 - 20% battery capacity).

When the charge falls below 20% of battery capacity (charge status low), both red LEDs flash .

Hour meter

Hour meter shows the machine's working hours. It starts to calculate when the truck is starting and working.

The hour meter has the memory of the previous operation. The final instruction is 1/10 in the display.

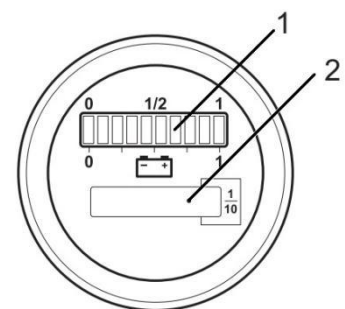

1.2.4 Emergency parking

After pressing the emergency stop switch, the vehicle electrical system circuit is cut off.

1.3 Standard configuration of technical data

1.3.1 Performance Data

1.3.2

Description		CBD15-170G
Rated capacity	kg	1500
Travel speed,with/without load	km/h	3/3.5
Lift speed,with/without load	mm/s	35/40
Lowering speed,with/without load	mm/s	45/40
Max.gradeability,with/without load	%	5/7

Dimensions Data

Description		CBD15-170G
Load centre distance with standard fork length	C (mm)	600
Wheel base	y (mm)	1301
Min.forks lowered	h4 (mm)	85
Max.fork lifting height	h3 (mm)	205
Lift	h5 (mm)	120
Width across forks	B5 (mm)	550/685
Track width	B2 (mm)	230/365
Fork length	l (mm)	1150
Fork width	e (mm)	160
Fork thickness/	s (mm)	75
Overall length	L1 (mm)	1707
Width of truck	B1 (mm)	697
Overal height(With handle)	h14 (mm)	1181
Overal height(Without handle)	h13 (mm)	714
Min.Turning radius	Wa (mm)	1547
Min.Aisle width for pallets 800x1200	Ast (mm)	1920
Min.Aisle width for pallets 1000x1200	Ast (mm)	1953

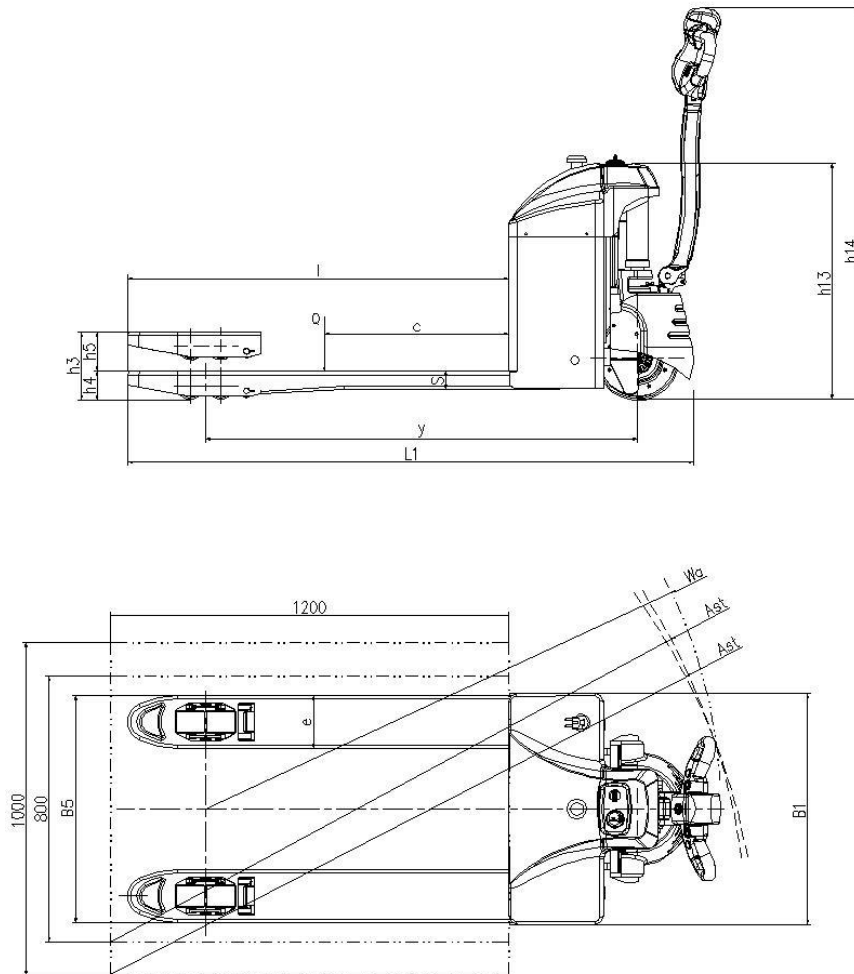

1.3.3 Weights

Description		CBD15-170G
Truck weight (with battery)	kg	258
Battery weight	kg	48

1.3.4 Battery

Description		CBD15-170G
Battery type	/	Acid Batteries
Voltage/capacity	V/Ah	24/85

1.3.5 Tyres

Description		CBD15-170G
Wheel type	/	PU
Wheel quantity Drive wheel/Balance wheel/load wheels	/	1/0/4
Wheel size, drive wheel	mm	Φ252X67
Wheel size, load wheels (2x) (Option)	mm	--
Balance wheel size	mm	Φ84X70

1.4 Data Plates

Electric Stacker		HELI	
Model		Total Weight (without battery)	
Configuration No.		Battery Weight (Max)	
Rated Capacity		Battery Weight (Min)	
Max Lift Height		Manufacture License No.	TS2510319-2022
Rated Voltage		Special Equipment Code	
Serial No.		Date of Manufacture	

ANHUI HELI CO., LTD.
MADE IN CHINA

Model

All necessary information

Manufacturer

2. Initial use

Vehicles are only allowed to use batteries as power!

In order to work properly after delivery or transportation, the following inspection must be carried out:

- Check whether the equipment is complete and in normal condition.
- If the battery is not installed, load and be careful not to damage the battery cable.
- Charge the battery.

3. Battery - Recharging, Replacement

3.1 Safety Regulations for Handling Acid Batteries

3.1.1 Fire protection

Do not smoke and avoid naked flames when handling batteries. Wherever an industrial truck is parked for charging there shall be no inflammable material or lubricants capable of creating sparks within 2 metres around the truck. The room must be ventilated. Fire protection equipment must be on hand.

The use of unsuitable fire-protection equipment can result in acid burns. In the event of fire a reaction with the battery acid can occur if water used to extinguish the fire. This can lead to acid burns.

- Use powder extinguishers.
- Never extinguish burning batteries with water.

3.1.2 Battery maintenance

The batteries must be kept dry and clean. Terminals and cable shoes must be clean, lightly greased with terminal grease and must be securely tightened.

3.2 Battery and charger Types

Battery		Charger	
Voltage	2X12 V	Input	AC 220V 50/60Hz
Capacity	85 Ah	Output	DC 24V/10A
The truck is fitted as standard with an on-board charger, the mains cable of the charger is supplied with the truck. CAUTION! The on-board charger must not be opened!			

3.3 Charging

Do not full charge the battery, it will damage the battery.

The battery needs to be charged within 24 hours after used out.

3.3.1 Charging

- Switch OFF
- Open the battery hood panel
- Connect the cable with the battery and charger

- Switch on charger to charge

3.3.2 Finish of charging

- Switch off the charger
- Disconnect the cable with the battery and charge
- Connect the cable with the battery and the truck

3.4 Battery Removal and Installation

● In case changing another battery, it has to be same weight like the original battery, the weight of battery is very important to the stability and brake performance of the pallet truck.

- It is forbidden to modify the battery weight and size.

3.4.1 Removing the battery

- Truck parked securely.
- Disconnect the cables with battery and truck.
- Using a hook to take off the battery carefully .
- Remove the B- battery cable and the black cable from the terminal.
- Remove the B+ battery cable and the red cable from the terminal.
- Remove the cable and place it by side.
- Lift out batteries individually.

3.4.2 Installment of battery

- Installation is the reverse order.
- Connect the cables with battery and truck.
- When reinstalling the batteries, make sure they are installed in the correct position and properly connected.

- After installing the battery, check all cables for visible signs of damage.

4. Industrial Truck Operation

4.1 Safety Regulations for Truck Operation

- Before driving the vehicle, ensure that the vehicle maintains an appropriate safe driving distance from surrounding items or personnel;
- When the vehicle starts, be careful not to start emergency or emergency braking, and slowly rotate the acceleration knob to prevent the shortening of the life of electrical components, such as motor overcurrent damage, excessive wear of electromagnetic brake friction plates, etc., especially when the new vehicle is running in;
- During driving, always pay attention to the surrounding environment, look ahead and drive carefully to prevent danger in the operation area. For areas that may be dangerous, such as corners, blind spots, etc., the driver must reduce the speed of the vehicle and press the horn to remind other personnel;
- When driving uphill or downhill, do not turn around. It is forbidden to drive horizontally or diagonally when going uphill, and when the load is going uphill, the fork must always be kept forward, and when going downhill, it should be driven backward;
- During the use of the vehicle, the driver finds that the vehicle is faulty or encounters potential safety hazards, please stop immediately, move the vehicle to a safe location, and make appropriate signs to prevent other people from using it;
- When the vehicle is in emergency situations such as automatic walking, the driver needs to quickly press the emergency brake switch button to cut off the main power of the vehicle. The electromagnetic brake can quickly hold the brake, the motor can cut off the power source, and the vehicle can quickly stop. Protect the driver's safety; The emergency brake switch should not be used as the driving brake unless the vehicle is parked for a long time;
- In order to prevent the uneven load of the vehicle, it is forbidden to carry the goods with a single fork, and it is forbidden to carry wide goods with a narrow fork;
- When using the vehicle, pay attention to the working performance of the vehicle, such as the maximum load corresponding to the center distance of the vehicle. It is strictly forbidden to overload the vehicle;
- For use in vicious working conditions, such as dust, uneven road surface or liquid road surface, in order to ensure the driver's own safety and ensure the operation of the vehicle, remember to slow down and avoid steering and braking loss of control due to rapid travel, and make sure you have enough braking distance.

4.2 Driving

Turn the control button (forward or backward) in the desired direction of travel.

The greater Angle of rotation, the faster the vehicle travelling.

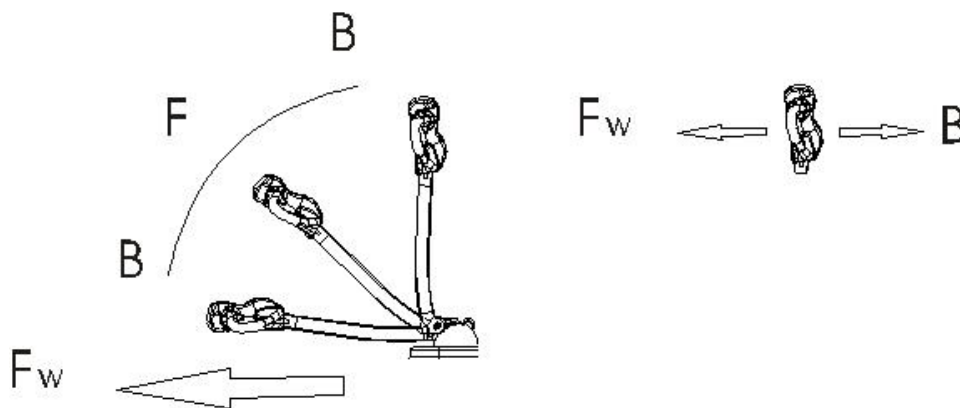

“F”area	driving area
“B”area	braking area
“F _w ”	forward
“B _w ”	backward

4.3 Steering

Steering is controlled by turning the operating handle to the left or right.

4.4 Braking

The braking performance of a vehicle depends on road conditions and load conditions, which must be considered during driving. There are three ways to brake:

4.4.1 Service brake

Move the handle up or down to the braking area (B).

- Release the operating handle and the handle will automatically move to the upper braking area (B).
- The pallet truck will brake until stop.

4.4.2 Inversion braking

- The truck brakes regeneratively when rotating the travelling switch ,until it starts to move in the opposite direction.

4.4.3 Regenerative braking

- When the travel switch is set to the zero position , the truck brakes to a halt regeneratively via the coasting brake.
- The mechanical brake applies below 1 km/h.

4.5 Parking vehicles safely

Note: No parking on slopes!

- Unload the goods on the platform.

- Press the emergency stop switch.
- Turn the key to the "OFF" position and pull out the key.

5. Maintenance and repair

5.1 Operation safety and environmental protection

- The inspection and maintenance operations described in this chapter must be performed according to the time limit listed on the maintenance checklist.
- Modifications to vehicles, especially safety devices, are prohibited. The working speed of the vehicle must not be changed.
- Only the original parts can meet the quality management requirements of the company. In order to ensure the stable and reliable operation performance of the equipment, only the original spare parts produced by our company can be used. Aging components and replacement liquid media must be treated in accordance with current environmental regulations. If you need to change the oil, you can contact our customer service department.
- After the inspection and maintenance operation is completed, the operation steps specified in the "re-commissioning" section must be followed.

5.2 Safety regulation for maintenance

5.2.1 Service person

Vehicle maintenance and repair can only be carried out by the company's professional technicians.

The company's service department has a team of technicians in charge of service. They have been specially trained to be competent in various maintenance operations of the equipment. We suggest that users sign a maintenance contract with our service point.

5.2.2 Lifting and jacking equipment

When lifting the vehicle, the lifting tool can only be installed in the specified fixed position.

When jacking up the vehicle, the equipment must be fixed with appropriate tools, such as wedge blocks, wooden blocks, etc., to prevent the risk of accidental rolling or tipping over.

If it is necessary to operate under the lifting load parts, the Fork must be secured with a strong enough chain.

5.2.3 Clean operation

Do not wash the vehicle with flammable liquid.

Before starting the cleaning operation, all necessary safety measures must be taken and sparks (e.g. due to a short circuit) must be prevented during the operation. If the vehicle is battery-powered, disconnect the battery cable.

When cleaning electrical and electronic components, use low-strength suction or compressed air. At the same time, use a non-conductive, anti-static brush to clean the dust on the surface of the component.

If the vehicle is washed with a water gun or high-pressure cleaning equipment, all electrical and electronic components must be carefully covered in advance, or the components may be affected by moisture, resulting in functional failure.

Steam stream cleaning equipment shall not be used.

After the cleaning operation is completed, the operation steps specified in the "recommissioning" section must be followed.

5.2.4 Operation to the electrical system

Operations related to electrical systems must be performed by professionals trained in electrical technology.

Before commencing operation, the operator must take all necessary measures to prevent an electrical accident.

If the vehicle is battery-powered, the key switch must be pulled out to prevent the vehicle from being started accidentally.

5.2.5 Regulation parameters

Maintenance and replacement of hydraulic, electrical and electronic components must be careful to comply with the vehicle - related parameters.

5.2.6 Vehicle tire

The quality of tires directly affects the stability and driving performance of the equipment. If it is necessary to replace the tires, the original spare parts provided by our company must be used.

When changing wheels or tires, make sure the vehicle does not tilt (for example, both left and right wheels should be replaced at the same time).

5.2.7 High pressure hose for hydraulic system

If the hydraulic assembly is replaced, the high pressure hose in the hydraulic system should also be replaced.

5.3 Maintenance and inspection

Comprehensive and standard maintenance is one of the most important preconditions to ensure stable and reliable operation performance and long service life.

Careless maintenance may lead to the breakdown and malfunction of truck and may pose a potential threat to staff and operational safety.

The wear and tear situation of the parts to be maintained depends largely on the actual operation and operating conditions of the truck. If the operating conditions of the intensity is higher than the general level, such as dust, temperature fluctuations, or the implementation of shift work system, must be appropriately shortened maintenance period.

The specific maintenance operation time are shown in the following table (maintenance checklist) :

W= every 50 running hours, but at least once a week

A= every 500 running hours, but at least every half a year

B= per 1000 operating hours, but at least once a year

C= every 2000 running hours, but at least once a year

When the vehicle is in the running-in stage (after approximately 100 hours of operation), the equipment user shall check the fixation of wheel nuts and bolts and retighten them if necessary.

HELLI 哈铃

5.3.1 Maintenance checklist

Maintenance listings		Time interval			
		W.	a.	B	C
The hydraulic system					
1	the hydraulic cylinder, piston for damage noise or leakage		●		
2	Inspect hydraulic connectors and hose for damage and leakage		●		
3	Check the hydraulic level and refill if necessary		●		
4	Refill with hydraulic oil (12 months or 1500 working hours)				●
5	Check and adjust pressure valve function (+10%)				●
Mechanical systems					
6	Check the platform structure for deformation and cracks		●		
7	Check the base for deformation and cracks		●		
8	Check that all screws are fixed		●		
9	Check gear box for noise and leakage		●		
10	Inspect wheels for deformation and damage		●		
11	Lubricated steering bearing				●
12	Check and lubricate central point		●		
13	Lubricating grease nozzle	●			
14	Replace the protection and/or protection plate if damaged	●			
Electrical system					
15	Check the wires for damage		●		
16	Check electrical connections and terminals		●		
17	Check the emergency stop switch function		●		
18	Check electric drive motor for noise and damage		●		
19	Detection meter		●		
20	Check that the correct fuse is used and replace it if necessary		●		
21	Detect the buzzer		●		
22	Check the current contactor		●		
23	Check frame for leakage (insulation test)		●		
24	Check the function and wear of accelerator		●		
25	Check the electrical system of the driving motor		●		
The braking system					
26	Check braking performance, replace brake disc or adjust		●		
Battery					
27	Check battery voltage		●		
28	Clean and grease terminal, check for corrosion and damage		●		
29	Check the battery shell for damage		●		
The charger					
30	Check the main power wires for damage			●	
31	Check the startup protection during charging			●	
Function					
32	Detect the buzzer	●			

33	Check the clearance of the electromagnetic brake	●			
34	Check the emergency braking function	●			
35	Check the reverse braking and regenerative braking functions	●			
36	Check belly switch function	●			
37	Check steering function	●			
38	Check lever switch function	●			
39	Check whether the key switch is damaged and functional	●			
Comprehensive					
40	Check all labels for clarity and completeness	●			
41	Check that the guard plate and/or guard are not damaged	●			
42	Inspect tires and adjust or replace height if there is wear		●		
43	Conduct a trial run	●			

5.3.2 Lubrication maintenance

Liquid medium

The use and handling of liquid media must be in strict accordance with the manufacturer's regulations.

Non-standard operation will endanger the health and life of operators and the surrounding environment. Liquid media can be stored in specified containers. The liquid medium may be flammable and should not be near high temperature parts or open flames.

Clean container must be used when adding liquid media. Mixing different liquid media with each other is strictly prohibited (except where mixing is specified in the instructions).

Be careful not to spill the liquid. If a liquid medium is spilled, a suitable adsorbent must be immediately applied to the surface of the medium and the mixture of the liquid medium and the adsorbent should be treated as prescribed.

Code	Name	Application
A	85W/90	Gear box
B	L-HV32	The hydraulic system
C	Grease (withMus2)	Turning frame

5.3.3 Maintenance instructions

Preparation before maintenance operation

To avoid accidents during maintenance, take all necessary safety measures. The following operations must be carefully obeyed:

- Park vehicles as regulation.

- Pull out the key switch to prevent the vehicle from being started accidentally.
- If it is necessary to operate under a rising vehicle, effective measures must be taken to prevent accidents such as roll over or sliding.

Replace drive wheel

Drive wheels can only be replaced by authorized maintenance person.

The replacement of the driving wheel can not be replaced when the vehi

Refill gear oil

Preparation well before maintenance operation.

- Remove the hood.
- Refill "1" with gear oil of correct specification.
- Replenishment every 1000 running hours, but at least once a year.

Install in reverse order.

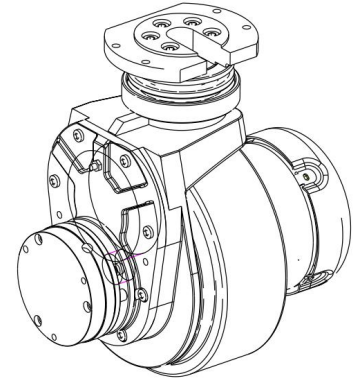

Check the hydraulic oil level

Air burst sound is heard in the oil pipe when lifting , It means that the hydraulic oil should be timely refill of hydraulic oil.

Caution !
Prohibit using impure hydraulic oil.

Replenish hydraulic oil steps

- Make preparations before maintenance operation.
- Remove the hood.
- Replenish the suitable hydraulic oil when necessary.

After that rise again, It is finished when no longer hear the air burst sound;

Continue refueling if there is still a blast.

Install in reverse order.

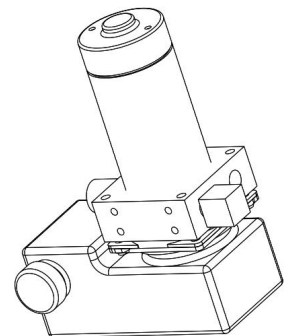

Check the electric protection instrument

- Make preparations before maintenance operation.
- Remove the hood.
- Check the electric protection instrument to make sure the parameter same like the table

below, otherwise it needs to be changed.

Item	Safety device	Parameter
1	Main fuse	80A
2	Fuse	10A

Reusing again

After cleaning or maintenance, the following operations must be performed before the vehicle can be reused.

- Check the function of the alarm.
- Check the function of emergency stop switch.
- Check the function of the brake.
- Lubricate the vehicle according to the maintenance diagram. If the car is parked for long term, the wheels around the ground may be flat slightly.

After a short ride, the flat part will automatically recover.

5.3.4 Disuse and storage

If the vehicle is out of service for more than 2 months, it must be stored in a frost-free dry space. The vehicle must be supported with a bracket and all wheels must be off the ground during storage. Only in this way the wheels and wheel bearings can be protected from damage during storage.

Precautions before storage

- Clean the vehicle completely.
- Check the brake.
- Apply a thin layer of oil or grease to all mechanical parts that have not been painted.
- Clean the battery, the lead acid battery should be covered with special grease on the electrode bolts. Recharge the battery.
- Please comply with the battery manufacturer's operating instructions and regulations.
- Spray all exposed contact surfaces with suitable spray.

Caution !

Charging every month, otherwise it will lack of electricity which lead to battery performance decline or damaged.

After the vehicle is put into use, the driver should test the braking performance repeatedly.

5.3.5 Safety inspection on the vehicle regularly or in case of abnormal conditions

Safety inspection shall be conducted in accordance with relevant national regulations.

Professionals trained by our company can provide customers with thoughtful security services. The vehicle must be inspected by a professional at least once a year (note national regulations) or in abnormal state. Inspectors must take operation safety as the starting point and objectively and accurately evaluate the performance and state of the equipment. Inspectors must have sufficient work experience to be able to evaluate the condition of equipment and the normal

performance of protective devices in accordance with current technical regulations and vehicle inspection standards. A comprehensive inspection must be carried out specifically for the safety and technical performance of the vehicle in the event of an accident. In addition, the vehicle must be thoroughly checked for any damage caused by improper use. Inspectors must keep careful records of the inspection process and related data. The inspection results must be maintained at least until the next inspection operation.

The equipment user must take necessary measures to solve the problems found in time.

HELLI 合力