

Curve deceleration wire

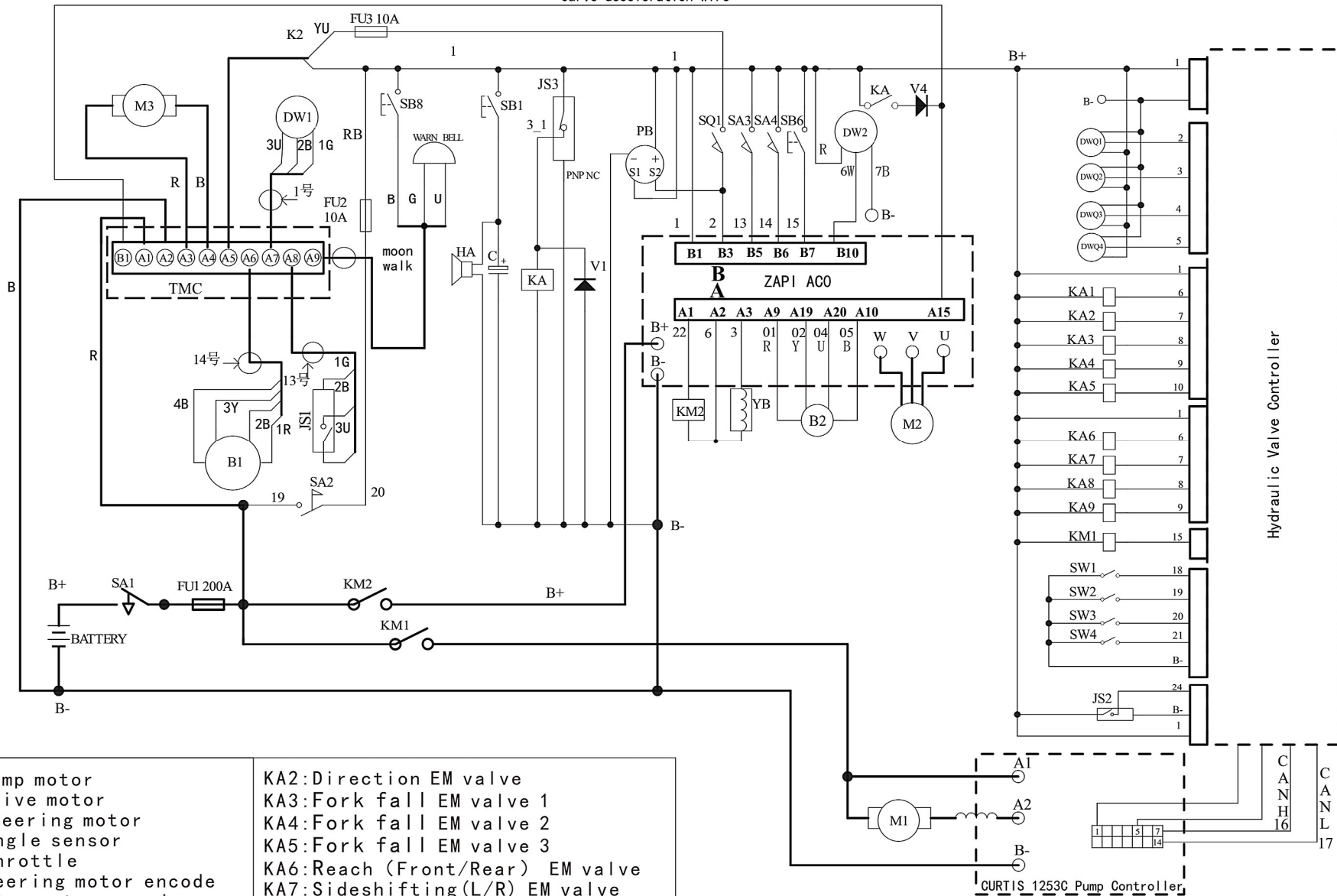

M1: Pump motor  
 M2: Drive motor  
 M3: Steering motor  
 DW1: Angle sensor  
 DW2: Throttle  
 B1: Steering motor encode  
 B2: Drive motor encode  
 SA1: Emergency stop switch  
 SA2: Key switch  
 SA3: Forward switch  
 SA4: Backward switch  
 SQ1: Interlock switch  
 SB1: Horn switch  
 SB6: EMR. switch  
 SB8: Moon walk switch  
 KA: Lift speed limit relay  
 KA1: Lift EM valve

KA2: Direction EM valve  
 KA3: Fork fall EM valve 1  
 KA4: Fork fall EM valve 2  
 KA5: Fork fall EM valve 3  
 KA6: Reach (Front/Rear) EM valve  
 KA7: Sideshifting (L/R) EM valve  
 KA8: Tilt (F/R) EM valve  
 KA9: Hyd EM valve  
 JS1: Steering proximity switch  
 JS2: Lift limit switch  
 JS3: Speed limit switch  
 KM1: Pump motor contactor  
 KM2: Drive motor contactor  
 DWQ1: Tilt switch  
 DWQ2: Reach (Front/Rear) switch  
 DWQ3: Lift/Fall switch  
 DWQ4: Sideshifting switch

PB: BDI  
 SW1: Reach (Front) limit switch  
 SW2: Reach (Rear) limit switch  
 SW3: Tilt (Front) limit switch  
 SW4: Tilt (Rear) limit switch  
 YB: Brake coil  
 TMC: Steering controller

Title: CQDH13/14-850 electric system diagram