

M1: Pump motor
M2: Drive motor
DW1: Throttle
SA1: Emergency stop switch

SA2: Key switch
SA3: Forward switch
SA4: Backward switch
SQ1: Interlock switch
SB1: Horn switch

SB2: Fork fall switch
SB3: Fork lift switch
SB6: EMR. switch
KA1: Lift limit switch
KM1: Pump motor contactor

KM2: Drive motor contactor
PB: BDI
YV1: Fall electromagnetic valve
YB: Brake coil

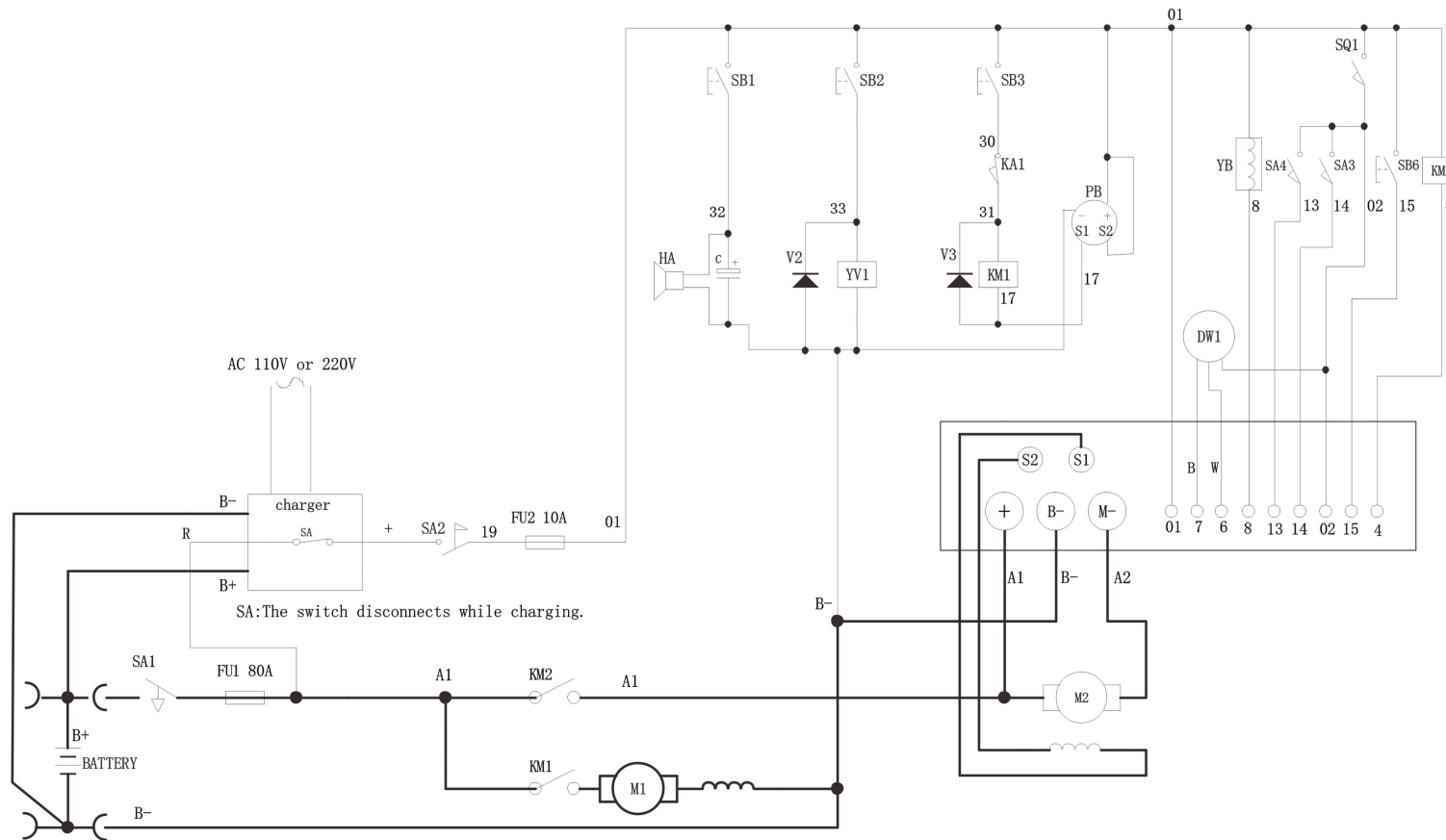

Title:170G/610/050/070/080/090/070E electric system diagram