



OPDS15

VNA battery truck (man-up)

Characteristics

1. The truck adopts three point support structure which features low center of gravity, good steering stability and small turning radius.
2. Two sets of independent energy-saving and consumption reducing energy regeneration systems are adopted.
3. The high-strength mast has stable and large bearing capacity at high position.
4. Full AC drive control technology features higher power and efficiency.
5. The smart management system and CAN-bus system can meet all kinds of requirements and make the truck safe and reliable.
6. Multi axis control technology improves work efficiency.
7. With self balancing control technology, the truck has good stability.
8. Interlock control is adopted for height and speed during driving to ensure dynamic stability of the truck.
9. The multi-level safety alarm system includes laser anti-collision sensor, emergency braking, audible and visual alarm to ensure personal and truck safety.
10. The ergonomic control handle is easy to operate, and the multi-functional LCD instrument displays truck conditions.
11. Tilt angle and height adjustable dash board are adopted. And operator's ideal sitting posture can be meted through the front and back adjustment seat.
12. Imported drive wheel, solenoid control valve, controller, contactor, steering potentiometer are adopted.
13. Slow, medium or fast mode can be selected according to different working conditions.
14. The on-board diagnosis system ensures the timeliness of maintenance and repair.



OPDS15 Product characteristics table					
Characteristics		OPDS15/6.5m	OPDS15/8m	OPDS15/9.2m	OPDS15/10.5m
1.1	model				
1.2	driving mode	Stand-up rider	Stand-up rider	Stand-up rider	Stand-up rider
1.3	Load capacity	Q(kg)	1500	1500	1500
1.4	Total lifting height	mm	6500	8000	9200
1.5	Load capacity at the highest	kg	1380	1150	950
1.6	Load centre distance	c(mm)	600	600	600
1.7	Front overhang	x(mm)	485±10	485±10	485±10
1.8	Wheel base	y(mm)	1928±20	1928±20	1928±20
1.9	Rear overhang	z(mm)	280	280	280
1.10	Service weight with battery	kg	7705	8105	8405
Wheels					
2.1	Wheels type		PU	PU	PU
2.2	Wheels size(Front)		380*192	380*192	380*192
2.3	Wheels size(Rear)		400*160	400*160	400*160
2.4	Wheels number front/rear(x=driven wheels)		2/1x	2/1x	2/1x
2.5	Front wheel base	b10(mm)	1362±10	1362±10	1362±10
Dimension					
3.1	Mast lowered height	h1(mm)	3745±20	4498±20	5098±20
3.2	Lift height	h3(mm)	4760	6260	7460
3.3	Mast extend height	h4(mm)	7428±20	8928±20	10128±20
3.4	Overhead guard height	h6(mm)	2564±20	2564±20	2564±20
3.5	Step height	h7(mm)	442±10	442±10	442±10
3.6	Auxiliary lifting height	h9(mm)	1740	1740	1740
3.7	Platform height after lifting	h12(mm)	5202±20	6702±20	7902±20
3.8	Overall length	l1(mm)	3805±20	3805±20	3805±20
3.9	Vehicle length to face of fork	l2(mm)	3470±20	3470±20	3470±20
3.10	Overall width	b1/b2(mm)	1210/1555	1210/1555	1210/1555
3.11	fork size: thickness×width×length	s/e/l(mm)	40x120x950	40x120x950	40x120x950
3.12	Fork carrier ISO 2328_class/type		2/B	2/B	2/B
3.13	Fork carriage width	b3(mm)	908	908	908
3.14	Width across forks	b5(mm)	870	870	870
3.15	Width across guide rollers	b6(mm)	1630	1630	1630
3.16	Lateral extension distance	b7(mm)	1300±20	1300±20	1300±20
3.17	Distance from side extension to center line of forklift truck	b8(mm)	480	480	480
3.18	Ground clearance at mast (Loaded)	m1(mm)	80	80	80
3.19	Ground clearance, center of wheelbase	m2(mm)	80	80	80
3.20	Aisle width with pallet 800x1200	Ast(mm)	1680	1680	1680
3.21	Turning radius	Wa(mm)	2220±20	2220±20	2220±20
3.22	Distance from front axle to fork pivot	l8(mm)	1150	1150	1150
3.23	Maximum picking height	h12+1600(mm)	6802±20	8302±20	9502±20
3.24	Pallet width	b12(mm)	1200	1200	1200
3.25	Pallet length	l6(mm)	1000	1000	1000
3.26	Width of cab entrance	mm	420	420	420
3.27	Inside height of cab	mm	2070±20	2070±20	2070±20
3.28	Overall width of cab exterior	b9(mm)	1430±10	1430±10	1430±10
3.29	Width of rotary front fork bracket	b14(mm)	1488	1488	1488
3.30	Cantilever width	l10(mm)	175	175	175
3.31	Distance from fork pivot to fork frame	r(mm)	155	155	155
Performance					
4.1	Travelling speed: loaded/unloaded (Mechanical guidance)	km/h	10/10	10/10	10/10
4.2	Lifting speed: loaded/unloaded	mm/s	280/300	280/300	280/300
4.3	Lowering speed: loaded/unloaded	mm/s	320/300	320/300	320/300
4.4	Reach speed: loaded/unloaded	mm/s	190/200	190/200	190/200
4.5	Service brake		Regenerative / Hydraulic	Regenerative / Hydraulic	Regenerative / Hydraulic
4.6	Parking brake		Electromagnetic brake	Electromagnetic brake	Electromagnetic brake
4.7	Axle load(with load),front/rear		7440/1765(Vertical release)	7640/1965(Vertical release)	7790/2115(Vertical release)
4.8	Axle load(without load),front/rear		4680/3025	4880/3225	4980/3425
Motor and battery					
5.1	Drive motor power-60 minutes	Kw	7.5	7.5	7.5
5.2	Lifting motor power-15 minutes	Kw	20	20	20
5.3	battery voltage/capacity (discharging capacity in 5 hours)	V/Ah	80/560	80/560	80/560
5.4	battery weight	kg	1480(1450-1510)	1480(1450-1510)	1480(1450-1510)
Others					
6.1	Type of drive control		AC	AC	AC
6.2	Sound pressure level at driver's ear	Db(A)	68	68	68
6.3	Steering type		Electronic steering	Electronic steering	Electronic steering

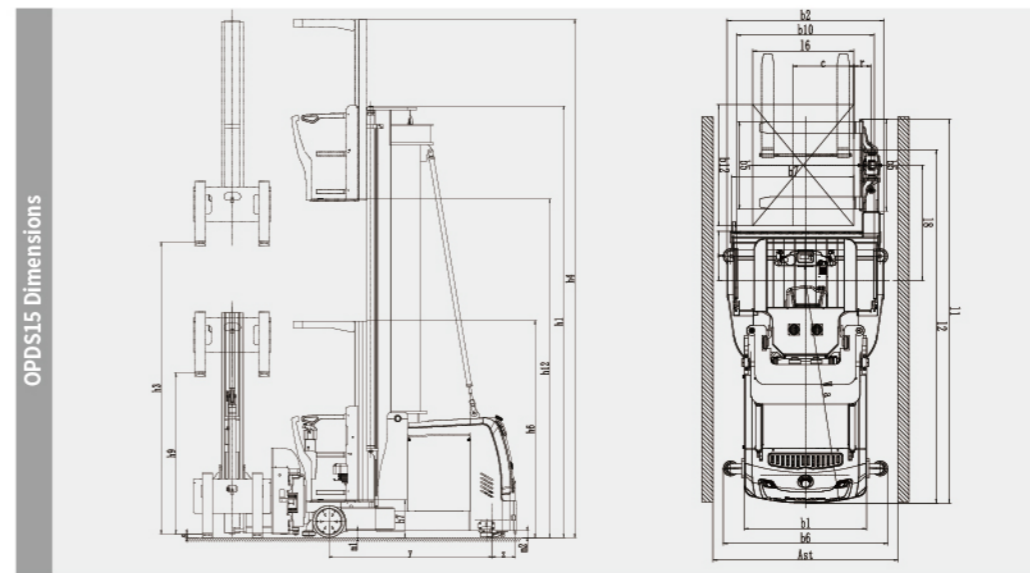

* Our products are subject to improvements and changes without notice.



ANHUI HELI CO., LTD.
 Add / No.668, FangXing Road, Hefei, China
 Fax / +86-551-63639966
 Tel / +86-551-63639068(America);
 63639258(Europe);
 63639358(Asia);
 63662105(Africa & Middle East);
 63639530(Key Accounts Division);
 63662105(Wheel loader)