

### CTD16-960H Electric Pallet Truck

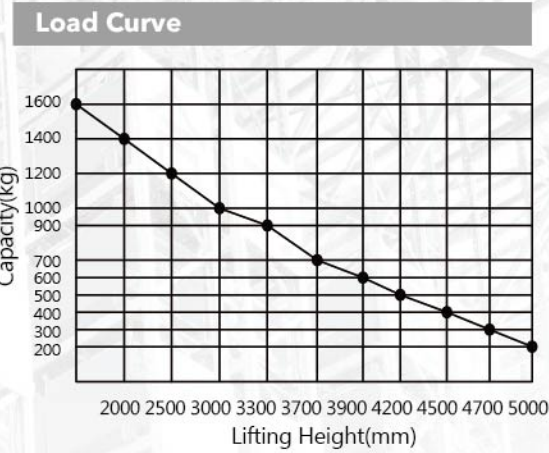

#### Configuration and performance

- Electronic power steering system, light and low noise;
- Two-way magnetic valve, three drop speed mode;
- AC Driving system, NO carbon brush, maintenance free;
- Automatic lifting limit, proximity switch, long life;
- Metal shell- High strength, safer.

#### Safety

- Curve automatic deceleration devices, more safe;
- Goods high position, vehicle automatic deceleration;
- Controller with Multiple automatic protection;
- Emergency reversing device/Emergency brake switch.

Feature		
Model		CTD16-960H
Type		Straddle
Mast type		Full free 3-stage
Loading capacity	lbs	3500
Load center	in	24
Operating type		walkie
Wheels type		PU
Lift height	in	177.2/185.0/196.9/212.6
Max.extend height	in	196.7/204.7/216.5/236.2
Mast lowered height	in	81.2/83.9/87.8/93.0
Overall length	in	75.2
Overall width	in	31.5
Min.Turning radius	in	59
Min.Aisle width for pallets 1000×1200	in	79.9
Travel speed,loaded/unloaded	mph	3.1/3.4
Lift speed,loaded/unloaded	fpm	25.6/35.4
Gradeability,loaded/unloaded	%	5/7
Battery voltage/capacity	V/Ah	24/270
Brake		Electromagnetic/Regenerative
Controller		ZAPI
Battery weight	lbs	539
Service weight with battery	lbs	3320

\* Details of specifications and equipment are based on information available at time of printing and may change without notice.

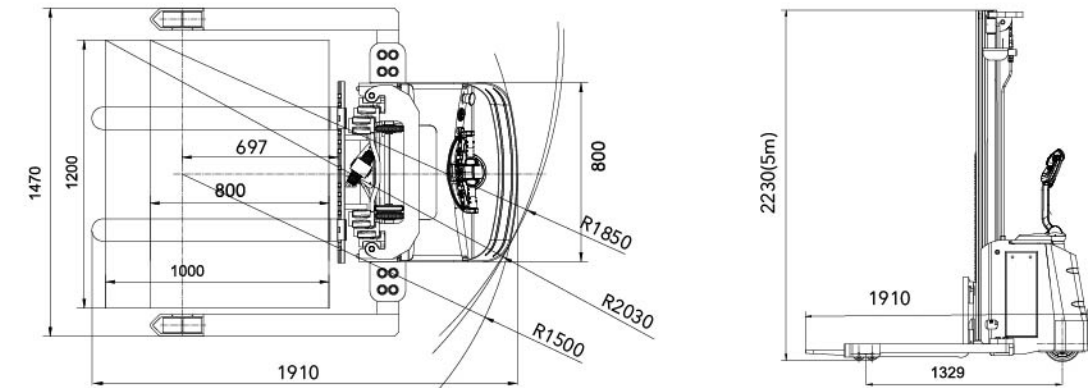

## HELI AMERICA INC

ADD: 4025 Welcome All Road, Suite 150 Atlanta, GA30349, U.S.A.

E-MAIL: heli@heliforkliftamerica.com

TEL: 404-242-3288

\* Our products are subject to improvements and changes without notice.