

HELI

CP(Q)YD15-20C 3000-4000lbs (1.5-2.0t) H3C IC Cushion Tire Forklift



CP(Q)YD15-20C



Heli H3C Series Features ***Improved performance Superior quality***

Ergonomics

- Vibration isolators separate the operator compartment from the main frame and the engine/transmission which absorb the truck's vibration for increased operator comfort.
 - Engine performance and repositioned hydraulic pump offer quieter and smoother operation and less noise.
 - Improved hydraulic control functions also reduce noise and increase performance.
-

Operator Comfort - Visibility

- Operator compartment has been enhanced by creating more foot and leg room with plenty of head room under the overhead guard.
- Visibility has been improved with narrower mast channels and more open overhead guard.
Higher contrast LED display makes it easier to see in all lighting conditions.
- Comfortable suspension seat is standard with full adjustment for different operators.
Low, wide step and grab handle make for easy entry to operator's compartment.
Controls and park brake are within easy reach to reduce operator strain.

CP(Q)YD15-20C



Increased Productivity

- Smaller turning radius and hydraulic power steering makes for tighter turns and easier steering operation.
- Reliable powershift transmission relieves operator from constantly shifting transmission.
- H3C series hydraulic performance has been enhanced for maximum productivity.
- Ergonomically designed operator's compartment enhances operator productivity, as well as providing safety and comfort.

Improved Performance

- All aluminum radiator increases air flow and dissipates heat more efficiently
- Smaller steering wheel with fewer turns lock-to-lock for quicker turns 35% faster lifting speeds over previous generations
- Lifting cylinders are damped to reduce noise and provide smoother operation
- Heavy duty powertrain offers exceptional performance in all applications

Serviceability

- AHood opens to an 80 degree angle and floor board is removable for easier access to all important chassis components
- Electrical system, wiring, and hydraulic hoses are convenient and logically laid out with access from above and below
- All grease points are accessible, including cast steel axle
- Lubrication chart is located on front of operator compartment to highlight essential lubrication requirements

Safety

- All Heli forklifts for North America meet ANSI B56.1 Safety Standard for Powered Industrial Trucks as well as meeting requirements for CE approval
- All Heli forklifts come standard with Operator Presence System
- Optional rear grab handle and horn button allows operator to safely drive in reverse
- Strobes, Beacons or Blue Lights and Alarms are all available

CP(Q)YD15-20C

Manufacturers Data and Design Characteristics

Character										
1.01	Manufacturer			HELI						
1.02	Model			CP (Q)YD15C-KU1H		CP (Q)YD18C-KU1H		CP (Q)YD20CS-KU1H		
1.04	Rated capacity	lbs	Kg	3000	1350	3500	1600	4000	1815	
1.05	Load center	in	mm	24	610	24	610	24	610	
1.06	Operation mode	type	type	Seat type						
Size										
2.01	Max.lifting height	H	in	mm	142	3600	142	3600	142	3600
2.02	Mast overall height(fork to the ground and mast be vertical)	H1	in	mm	83	2110	83	2110	83	2110
2.03	Max.fork lifting height(with backrest)	H2	in	mm	183.5	4660	183.5	4660	183.5	4660
2.04	Free lift height	H3	in	mm	6	155	6	155	6	155
2.05	Overall height(overhead guard)	H4	in	mm	83	2105	83	2105	83	2105
2.06	Min.ground clearance (mast/central of body)	H5	in	mm	2.4/3.3	60/83	2.4/3.3	60/83	2.4/3.3	60/83
2.07	Distance from the surface of the seat to the overhead guard	H6	in	mm	38.3	974	38.3	974	38.3	974
2.08	Traction pin height	H9	in	mm	4.0	100	4.0	100	4.0	100
2.09	Backrest height(calculated from the surface of the fork)	H13	in	mm	37.8	960	37.8	960	37.8	960
2.10	Overall length(with fork/without fork)	(L/L')	in	mm	119/82.5	3015/2095	120.3/84	3055/2135	122/85.5	3095/2175
2.11	Wheel base	L1	in	mm	50.4	1280	50.4	1280	50.4	1280
2.12	Overhang (front/rear)	L2	in	mm	16.7/14.9	425/380	16.7/16.5	425/420	16.7/18.1	430/460
2.13	Overall width	W1	in	mm	37.6	955	37.6	955	37.6	955
2.14	Tread (front tread/rear tread)	(W3/W2)	in	mm	31.5/32.1	800/815	31.5/32.1	800/815	31.5/32.1	800/815
2.15	Fork adjustable range(the external of the fork)(Max./Min.)	W5	in	mm	35/7.9	890/200	35/7.9	890/200	35/7.9	890/200
2.16	Min.turning radius(exterior)	r	in	mm	69.3	1740	70.9	1800	72.2	1820
2.17	Min.turning radius(interior)	r'	in	mm	1.9	50	1.9	50	1.9	50
2.18	Min.right angle stacking aisle width	Ra	in	mm	121.5	3085	123.8	3145	124.8	3170
2.19	Mast tilting angle	α/β			6°/5°					
2.20	Fork Size	L4×W×T	in	mm	36.2×3.9×1.4	920×100×35	36.2×3.9×1.4	920×100×35	36.2×4.8×1.6	920×122×40
Performance										
3.01	Max.traveling speed (loaded/unloaded)	mph	Km/h	9.94/9.94	16/16	9.94/9.94	16/16	9.94/9.94	16/16	
3.02	Lifting Speed (loaded/unloaded)	ft/s	mm/s	21.7/22.8	550/580	21.7/22.8	550/580	21.7/22.8	550/580	
3.03	Lowing Speed (loaded/unloaded)	ft/s	mm/s	17.7/19.7	450/500	17.7/19.7	450/500	17.7/19.7	450/500	
3.04	Max.drawbar pull (loaded/unloaded)	lbf	KN	4496.2/2248.1	20/10	4496.2/2135.7	20/9.5	4496.2/2135.7	20/9.5	
3.05	Max.gradeability (loaded/Inloaded)	%	%	35/20		32/20		30/20		
Weight										
4.01	Total weight	lbs	Kg	6657.9	3020	7165	3250	7605.9	3450	
4.02	Weight distribution loaded (front/rear)	lbs	Kg	8465.8/1168.4	3840/530	9343.2/1349.2	4238/612	10031/1543.2	4550/700	
4.03	Weight distribution unloaded (front/rear)	lbs	Kg	3097.5/3560.5	1405/1615	2976.2/4188.8	1350/1900	2870.4/4735.5	1302/2148	
Wheel and tyre										
5.01	Wheel number x = drive wheel (front/rear)			2/2						
5.02	Tyre type(front/rear)			cushion tyre/cushion tyre						
5.03	Tyre size(front)			18×6×12(1/8)						
5.04	Tyre size(rear)			14×5×10						
5.05	Service brake			Hydraulic-Foot Pedal						
5.06	Parking brake			Mechanical-Hand Lever						
Engine Model and Specification										
6.01	Model			CPYD15C-KU1H		CPYD18C-KU1H		CPYD20CS-KU1H		
6.02	Battery(Voltage/Capacity)	V/Ah		12/60						
6.03	Engine mode			Kubota WG2503						
6.04	Engine rated power	HP/rpm	KW/rpm	LPG: 58.3/2600 Gasoline:57.4/2600	LPG: 43.5/2600 Gasoline:42.8/2600	LPG: 58.3/2600 Gasoline:57.4/2600	LPG: 43.5/2600 Gasoline:42.8/2600	LPG: 58.3/2600 Gasoline:57.4/2600	LPG: 43.5/2600 Gasoline:42.8/2600	
6.05	Engine rated torque	(lbf.ft)/rpm	Nm/rpm	LPG: 128.1/1400 Gasoline:120.4/1800	LPG: 173.7/1400 Gasoline:163/1800	LPG: 128.1/1400 Gasoline:120.4/1800	LPG: 173.7/1400 Gasoline:163/1800	LPG: 128.1/1400 Gasoline:120.4/1800	LPG: 173.7/1400 Gasoline:163/1800	
6.06	Engine cylinder number-bore x stroke			4						
6.07	Piston displacement	L		2.491						
6.08	Engine fuel tank capacity	L		26						
6.09	Transmission box shifting gears(front/rear type)			1-1Power Shift T/M						

CP(Q)YD15-20C

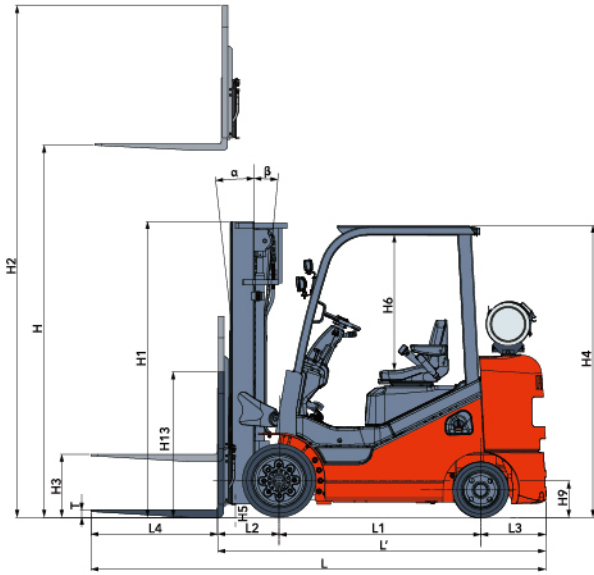

Ast: Right angle stacking aisle width

a: Clearance

L4: Fork Length

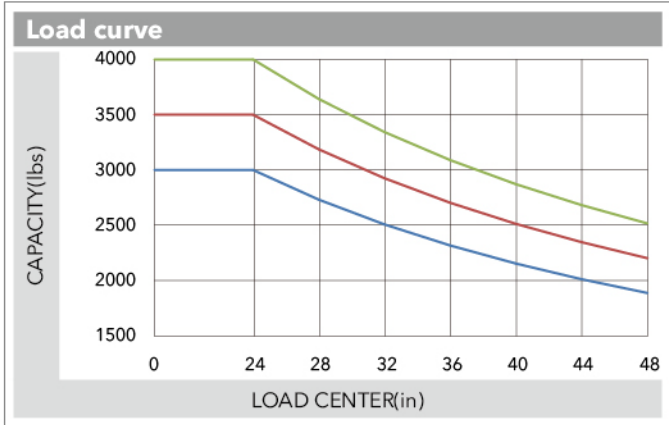
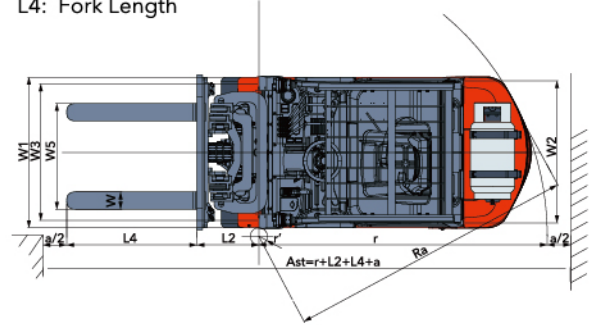

[CP \(Q\)YD15C-KU1H](#)

[CP \(Q\)YD18C-KU1H](#)

[CP \(Q\)YD20CS-KU1H](#)

Note: Capacities shown are reference only. They are computed with mast in vertical position based on 48 inch cube load configuration with center of gravity at true center of cube and standard forks. Longer forks and unusually wide loads can reduce capacity. Consult dealer for any questions about capacities.

WIDE VIEW FULL FREE 3-STAGE MAST

Mast type	Max lifting height mm/in	Capacity(load center 610mm/24in)			Overall height			Freelift (with backrest)		Tilt angle (front/rear) (°)	Service Weight(unload)		
		CP(Q)YD 15C	CP(Q)YD 18C	CP(Q)YD 20CS	CP(Q)YD 15C	CP(Q)YD 18C	CP(Q)YD 20CS	CP(Q)YD 15-18C	CP(Q)YD 20CS		CP(Q)YD 15C	CP(Q)YD 18C	CP(Q)YD 20CS
		Kg/lbs	Kg/lbs	Kg/lbs	mm/in	mm/in	mm/in	mm/in	mm/in		kg/lbs	kg/lbs	kg/lbs
ZSM360	3600/142	1350/2976	1600/3527	1800/3968	1750/69	1750/69	1750/69	740/29	745 /29	6/5	3130/6900	3380/7450	3600/7940
ZSM400	4000/157	1350/2976	1600/3527	1800/3968	1885/74	1885/74	1885/74	875/34	880/35	6/5	3160/6970	3400/7500	3630/8000
ZSM435	4350/171	1350/2976	1600/3527	1800/3968	2000/79	2000/79	2000/79	990/39	995/39	6/5	3180/7010	3430/7560	3650/8050
ZSM450	4500/177	1350/2976	1600/3527	1800/3968	2050/81	2050/81	2050/81	1040/41	1045/41	6/5	3190/7030	3440/7580	3660/8070
ZSM470	4700/185	1250/2750	1500/3307	1700/3748	2120/83	2120/83	2120/83	1110/44	1115/44	6/5	3210/7080	3450/7600	3670/8090
ZSM480	4800/189	1150/2530	1400/3086	1650/3638	2150/85	2150/85	2150/85	1140/45	1145/45	6/5	3220/7100	3460/7630	3680/8110
ZSM500	5000/197	1100/2420	1300/2860	1500/3307	2250/89	2250/89	2250/89	1240/49	1245/49	6/5	3240/7140	3480/7670	3700/8160
ZSM540	5400/213	1000/2200	1200/2646	1100/2425	2375/94	2375/94	2375/94	1365/54	1370/54	3/5	3260/7190	3510/7710	3730/8220
ZSM600	6000/236	650/1430	700/1543	900/1984	2600/102	2600/102	2600/102	1590/63	1595/63	3/5	3330/7340	3580/7890	3800/8380

NOTE: 1.5-1.8T: free lift height (without backrest)+465mm/18.3in; 2T: free lift height (without backrest)+465mm/18.3in;

Reliable special designed instrument



	Engine coolant temperature
	Fuel level
	Temperature of torque converter oil
	Pressure of torque converter oil
	LPG pressure
	Left turning
	Right turning
	Alarm of low fuel
	Hourmeter

	Charging indication
	Block of air cleaner
	Hand brake
	Seat switch
	Neutral indicator
	Safety belt switch
	Engine alarm
	Alarm of engine oil pressure

Standard configuration

Horn	Front combo lights	Speed-limiting valve
Three-spool control valve	Transmission oil filter	Lifting and tilting operation lever
3-stage full free lift mast	Rear combo lights	Tow pin
Power steering	Back-up alarm	Overhead guard
Semi-suspension seat	Overhead guard rain cover	Combined display
Load backrest	Standard forks	LPG Low Fuel Indicator
Rear view mirror	Integrated electric box	

Optional

Max. speed control system	Lifting OPS control system	LED headlights
LED Rotating Light	Torque converter oil temperature meter	No hand brake alarm
Dual Air Filter	Optional attachments	Rear grab handle with horn button
Hydraulic Fork Positioner	Rotating seat for LPG	
Rear work light	Swing Out/Drop-Down LPG Bracket	



* Details of specifications and equipment are based on information available at time of printing and may change without notice.

HELI AMERICA INC

ADD: 4025 Welcome All Road, Suite 150 Atlanta, GA30349, U.S.A.

E-MAIL: heli@heliforkliftamerica.com

TEL: 404-242-3288