

# HELI

## 5-10 t

**G series Internal Combustion  
Counterbalanced  
Forklift Truck**



[www.heliforklift.net](http://www.heliforklift.net)

# G SERIES 5-10 t



## **Technical features** *remarkably improved*

### **Damping**

- > With suspension damping structure on overhead guard(cab) and optimized design for the transmission, the whole trucks's vibration reduced a lot and relieve driver's fatigue greatly.

### **Noise reduction**

- > Equipped with fully sealed cab and optimize designed parts around the engine, noise nearby ear and the truck sound level are reduced greatly.

Independent integrated electric cabinet



LED signal (standard configuration)





## Heat dissipation

- > With the optimized cooling system and great cooling performance, highly improved the reliability and durability of the transmission and engine, etc, many key parts.

## Energy efficiency

- > With optimized hydraulic system, the truck is more energy-efficient and lower fuel consumption.

## Comfort

- > Man-machine engineering design improves operation comfort; wide view lifting system improves vision.

## Intelligent gear shifting

- > With electronic-hydraulic reversing system as standard configuration, make operation more liaght and easy; The updated new intelligent gear shifting system could avoid starting with second gear, improves the transmission box's realiability.

## Maintainability

- > Wider internal space, more reasonable parts layout and 80°hood opening angle make maintenance easy.

## Reliability

- > Key parts like frame and mast apply CAE top-down design to improve their strength and make the truck tough.



Locked fuel tank cover



Ratchet type parking brake



Folder

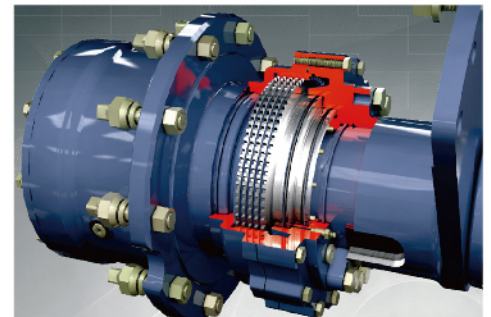

Wet-disc brake driving axle (optional choice):  
Advantages: the convenient operation, stable braking and free from maintenance.

# G SERIES 5-10 t

## Manufacturer and technical parameters

Characteristics								
1.01	Manufacturer					HELI		
1.02	Model			CPCD50	CPCD60	CPCD70	CPCD85	CPCD100
1.03	Power type			Diesel				
1.04	Rated capacity	Q	kg	5000	6000	7000	8500	10000
1.05	Load center	c	mm	600				
1.06	Driving mode			Sit-on type				
Dimensions								
2.01	Mast height, extended (with backrest)	H2	mm	4400	4400	4400	4450	4415
2.02	Max. fork height	H	mm	3000	3000	3000	3000	3000
2.03	Mast height, lowered	H1	mm	2500	2500	2500	2700	2850
2.04	Free lift	H3	mm	200	200	200	200	200
2.05	Backrest height (calculated from the fork surface)	H13	mm	1355	1350	1345	/	/
2.06	Overhead guard clearance (from face of seat)	H6	mm	1060	1060	1060	1060	1060
2.07	Overhead guard height	H4	mm	2450	2450	2450	2560	2560
2.08	Overall length (with forks)	L	mm	4710	4790	4840	5180	5430
2.09	Overall length (without forks)	L'	mm	3490	3570	3620	3960	4210
2.10	Front overhang	L2	mm	590	595	600	705	720
2.11	Rear overhang	L3	mm	600	675	720	755	715
2.12	Wheel base	L1	mm	2300	2300	2300	2500	2775
2.13	Traction pin center height	H9	mm	410	410	410	520	520
2.14	Min. Ground clearance (from bottom of mast)	H5	mm	200	200	200	250	250
2.15	Truck body width	W1	mm	2045	2045	2045	2165	2165
2.16	Lateral fork adjustment (outside of fork)(max./min.)	W6	mm	300-1835	300-1835	300-1835	420-1915	420-2060
2.17	Front tread	W3	mm	1520	1520	1520	1600	1600
2.18	Rear tread	W2	mm	1700	1700	1700	1700	1700
2.19	Min. Turning radius (external)	r	mm	3240	3300	3370	3650	3900
2.20	Min. Turning radius (internal)	r'	mm	200	200	200	200	200
2.21	In. right angle stacking aisle width (standard load size 1200X1200)	Ast	mm	5250	5315	5390	5775	6040
2.23	Mast tilting angle (forward /rear)	$\alpha / \beta$	$^{\circ}$	6/12	6/12	6/12	6/12	6/12
2.24	Fork size	L4	mm	55X1220X150	60X1220X150	65X1220X150	70X1220X175	80X1220X175
Tyre								
3.01	Wheel number (front/rear)			4X/2				
3.02	Tyre type (front/rear)			Pneumatic tyre				
3.03	Tyre size (front)			8.25-15-14PR			9.00-20-14PR	
3.04	Tyre size (rear)			8.25-15-14PR			9.00-20-14PR	
Specifications of the brake and transmission devices								
4.01	Battery (voltage/capacity)	V/Ah		2X12/80				
4.02	Service brake			Powered brake-pedal type				
4.03	Parking brake			Mechanical-hand brake lever type				
4.04	Oil tank capacity	L		160				
4.05	Transmission type			Intelligent gear shifting				
4.06	Transmission number of speed (fwd/bwd)			2/2				
Truck specifications								
5.01	Max. Travelling speed (loaded/unloaded)	km/h		28/30	28/30	28/30	27/30	27/30
5.02	Lifting speed (loaded/unloaded)	mm/s		500/520	500/520	500/520	390/420	330/350
5.03	Lowering speed (loaded/unloaded)	mm/s		WITHOUT LOAD $\geq 300$ WITH FULL LOAD $\leq 600$				
5.04	Max. Draw bar (loaded)	KN		62	62	62	58	58
5.05	Max. Gradeability (loaded/unloaded)	%		33/20	32/20	30/20	27/20	22/20
5.06	Weight (oil included)	kg		8150	8900	9500	11400	12510
5.07	Axle load (loaded) front/rear	kg		11830/1320	13330/1570	14450/2050	17750/2150	20030/2480
5.08	Axle load (unloaded) front/rear	kg		4050/4100	4005/4895	3900/5600	6040/5360	5510/7000
Engine specifications								
6.01	Engine manufacturer /mode			ISUZU 6BG1				
6.02	Engine rated power/rotational speed	Kw/rpm		82/2000				
6.03	Engine rated torque/rotational speed	Nm/rpm		415/1400-1600				
6.04	Cylinder number			6				
6.05	Engine displacement	L		6.494				

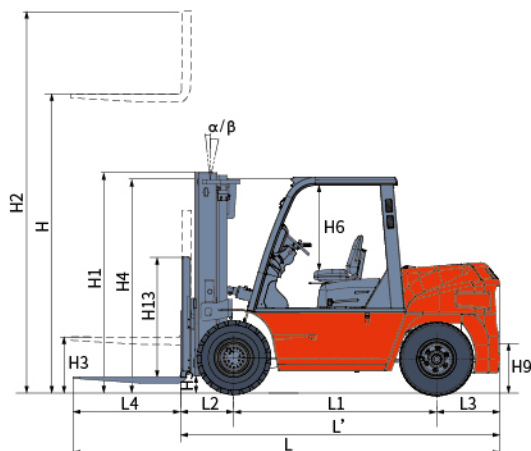

Ast: Right angle stacking aisle width  
a: Safety clearance 200mm

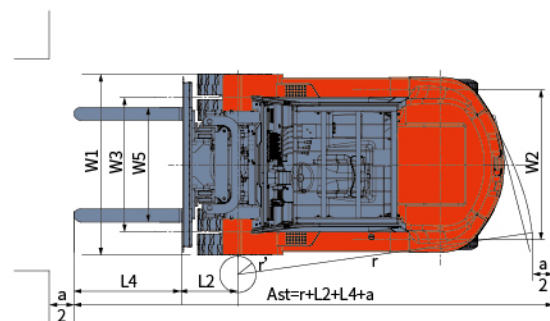

# G SERIES 5-10 t

## Optional engine model and truck main specifications 1

Truck specifications										
Model Designation		CPCD50	CPCD60	CPCD70	CPCD85	CPCD100	CPCD50	CPCD60	CPCD70	
Max. Travelling speed (loaded/unloaded)	km/h	26/30	26/30	26/30	26/30	26/30	22/26	21/26	20/26	
Lifting speed (loaded/unloaded)	mm/s	500/520	500/520	485/520	390/420	330/350	450/515	410/515	370/515	
Lowering speed (loaded/unloaded)	mm/s	WITHOUT LOAD ≥ 300 WITH FULL LOAD ≤ 600								
Max. Draw bar (loaded)	KN	62	62	62	60	60	51	51	51	
Max. Gradeability (loaded/unloaded)	%	39/20	34/20	30/20	22/20	20/20	40/22	35/20	32/18	
Weight (oil included)	kg	8150	8900	9500	11400	12510	8150	8900	9500	
Axle load (loaded) front/rear	kg	11830/1320	13330/1570	14450/2050	17750/2150	20030/2480	11830/1320	13330/1570	14450/2050	
Axle load (unloaded) front/rear	kg	4050/4100	4005/4895	3900/5600	6040/5360	5510/7000	4050/4100	4005/4895	3900/5600	
Engine specifications										
Engine manufacturer /mode		Cummins QSF3.8(Euro IIIA, CHINA STAGE III)					Deutz TCD 3.6 L04 (Euro V)			
Engine rated power/rotational speed	Kw/rpm	86/2200					55.4/2200			
Engine rated torque/rotational speed	Nm/rpm	470/1100~1700					406/1300			
Cylinder number		4					4			
Engine displacement	L	3.8					3.6			

## Optional engine model and truck main specifications 2

Truck specifications										
Model Designation		CPCD50	CPCD60	CPCD70	CPCD85	CPCD100	CPCD50	CPCD60	CPCD70	
Max. Travelling speed (loaded/unloaded)	km/h	26/30	26/30	26/30	27/30	26/30	26/30	26/30	26/30	
Lifting speed (loaded/unloaded)	mm/s	485/540	485/540	485/540	390/420	330/350	450/470	440/470	420/460	
Lowering speed (loaded/unloaded)	mm/s									
Max. Draw bar (loaded)	KN	62	62	62	62	62	42	40	40	
Max. Gradeability (loaded/unloaded)	%	33/19	32/19	30/19	22/20	20/20	23/19	20/19	20/19	
Weight (oil included)	kg	8150	8900	9500	11400	12510	8300	9050	9650	
Axle load (loaded) front/rear	kg	11830/1320	13330/1570	14450/2050	17750/2150	20030/2480	11940/1360	13400/1650	14550/2150	
Axle load (unloaded) front/rear	kg	4050/4100	4005/4895	3900/5600	6040/5360	5510/7000	4130/4170	4060/4990	3870/5780	
Engine specifications										
Engine manufacturer /mode		QUANCHAI 4J1(CHINA STAGE III)					Mitsubishi S6S-T			
Engine rated power/rotational speed	Kw/rpm	85/2200					63.9/2300			
Engine rated torque/rotational speed	Nm/rpm	500/1600					285/1700			
Cylinder number		4					6			
Engine displacement	L	4.3					4.29			

## Optional engine model and truck main specifications 3

Truck specifications										
Model Designation		CPCD50	CPCD60	CPCD70	CPCD85	CPCD100	CP(Q)YD50	CP(Q)YD60	CP(Q)YD70	
Max. Travelling speed (loaded/unloaded)	km/h	26/30	26/30	26/30	26/30	26/30	26/27	26/27	26/27	
Lifting speed (loaded/unloaded)	mm/s	550/570	550/570	550/570	430/450	350/370	470/430	470/430	400/370	
Lowering speed (loaded/unloaded)	mm/s									
Max. Draw bar (loaded)	KN	62	62	62	56	56	52	52	52	
Max. Gradeability (loaded/unloaded)	%	42/22	36/20	32/20	24/20	21/20	32/20	30/20	28/20	
Weight (oil included)	kg	8150	8900	9500	11400	12510	8150	8900	9500	
Axle load (loaded) front/rear	kg	11830/1320	13330/1570	14450/2050	17750/2150	20030/2480	11830/1320	13330/1570	14450/2050	
Axle load (unloaded) front/rear	kg	4050/4100	4005/4895	3900/5600	5360/6040	5510/7000	4050/4100	4005/4895	3900/5600	
Engine specifications										
Engine manufacturer /mode		Cummins QSB4.5(EU Stage IIIB, US EPA Tier 4(i), CHINA STAGE III)					Kubota WG3800			
Engine rated power/rotational speed	Kw/rpm	82/2200					Certificated/ non certificated type single fuel (LPG) :63.2/2400; Certificated type dual fuel (GAS, LPG) :54.6/2400; Non certificated type dual fuel (GAS, LPG) : 56.8, 59.9/2400			
Engine rated torque/rotational speed	Nm/rpm	489/1500					Certificated/ non certificated type single fuel (LPG) 290/1200; Certificated type dual fuel (GAS, LPG) 258/1200; Non certificated type dual fuel (GAS, LPG) : 265, 282/1200			
Cylinder number		4					4			
Engine displacement	L	4.5					3.8			



# G SERIES 5-10 t

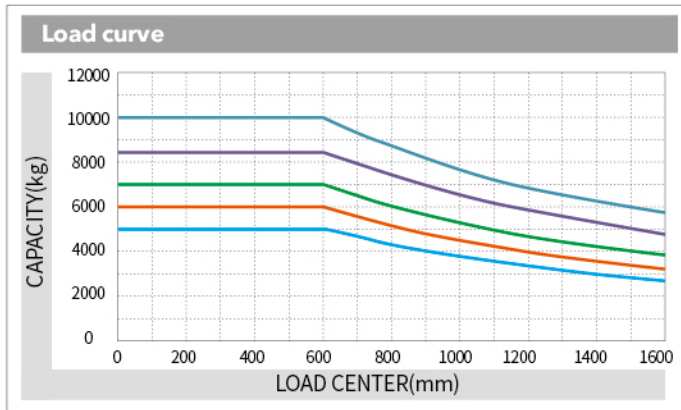

CPCD50    CPCD60    CPCD70    CPCD85    CPCD100

**Note:** The vertical axis stands for load capacity and the horizontal axis stands for load center which is calculated from the front surface of the forks to the gravity of the standard load. the standard load means a cubic with 1200mm edge length. When mast is tilted forward, using non-standard forks or loading large goods, the load capacity will be reduced. The load capacity of standard mast at different load center can be known from this load chart.

## 5-7t WIDE VIEW MAST

Mast model	Max. fork height (mm)	Load capacity (load center 600mm)(kg)			Mast height, lowered (mm)	Service weight (kg)			Mast tilting angle α / β
		CPCD50	CPCD60	CPCD70		CPCD50/60/70	CPCD50	CPCD60	
M200	2000	5000	6000	7000	2000	8005	8755	9409	6°/12°
M250	2500	5000	6000	7000	2250	8069	8819	9473	6°/12°
M270	2700	5000	6000	7000	2350	8101	8851	9451	6°/12°
M300	3000	5000	6000	7000	2500	8150	8900	9500	6°/12°
M330	3300	5000	6000	7000	2650	8199	8949	9549	6°/12°
M350	3500	5000	6000	7000	2750	8231	8981	9581	6°/12°
M375	3750	5000	6000	7000	2875	8272	9022	9622	6°/12°
M400	4000	5000	6000	7000	3050	8438	9188	9788	6°/12°
M425	4250	5000	6000	7000	3175	8478	9228	9828	6°/12°
M450	4500	5000	6000	7000	3300	8519	9269	9869	6°/12°
M475	4750	5000	6000	7000	3425	8560	9310	9910	6°/6°
M500	5000	5000	6000	7000	3550	8600	9350	9950	6°/6°
M550	5500	4750	5700	6600	3850	8794	9544	10144	6°/6°
M600	6000	4400	5400	6400	4100	8876	9626	10226	6°/6°

## 5-7t WIDE VIEW FULL FREE 2-STAGE MAST

Mastmodel	Max. fork height (mm)	Load capacity (load center 600mm)(kg)			Mast height, lowered (mm)	Free lift (with backrest) (mm)	Service weight (kg)			Mast tilting angle α / β
		CPCD50	CPCD60	CPCD70			CPCD50/60/70	CPCD50	CPCD60	
ZM250	2500	5000	6000	7000	2210	840	8189	8939	9539	6°/12°
ZM270	2700	5000	6000	7000	2310	940	8226	8976	9576	6°/12°
ZM300	3000	5000	6000	7000	2460	1090	8283	9033	9633	6°/12°
ZM330	3300	5000	6000	7000	2610	1240	8340	9090	9690	6°/12°
ZM350	3500	5000	6000	7000	2710	1340	8377	9127	9727	6°/12°
ZM375	3750	5000	6000	7000	2835	1465	8425	9175	9775	6°/12°
ZM400	4000	5000	6000	7000	3010	1640	8600	9350	9950	6°/12°
ZM425	4250	5000	6000	7000	3135	1765	8652	9402	10002	6°/12°
ZM450	4500	5000	6000	7000	3260	1890	8695	9445	10045	6°/12°
ZM475	4750	5000	6000	7000	3385	2015	8742	9492	10092	6°/6°
ZM500	5000	5000	6000	7000	3510	2140	8779	9529	10129	6°/6°
ZM550	5500	4750	5700	6600	3810	2440	8999	9749	10349	6°/6°
ZM600	6000	4400	5400	6400	4060	2690	9094	9844	10444	6°/6°

Note: (1) 5-6t: the free lift without backrest 465mm increased,(2) 7t: the free lift without backrest 310mm increased,

## 5-7t WIDE VIEW FULL FREE 3-STAGE MAST

Mastmodel	Max. fork height (mm)	Load capacity (load center 600mm)(kg)			Mast height, lowered (mm)	Free lift (with backrest) (mm)	Service weight (kg)			Mast tilting angle α / β
		CPCD50	CPCD60	CPCD70			CPCD50/60/70	CPCD50	CPCD60	
ZSM360	3600	4500	5600	6200	2335	910	8833	9583	10083	6°/6°
ZSM400	4000	4500	5600	6200	2470	1040	8893	9643	10143	6°/6°
ZSM435	4350	4500	5600	6200	2585	1156	8951	9701	10201	6°/6°
ZSM450	4500	4500	5600	6200	2635	1205	2808	2808	2808	6°/6°
ZSM480	4800	4500	5600	6200	2740	1310	9148	9898	10398	6°/6°
ZSM500	5000	4500	5600	6200	2805	1380	9179	9929	10429	6°/6°
ZSM540	5400	4200	5300	6000	2940	1510	9248	9998	10498	6°/6°
ZSM600	6000	4000	5000	5600	3140	1710	9337	10087	10587	6°/6°
ZSM650	6500	3500	4500	5000	3405	1975	9426	10176	10676	6°/6°
ZSM700	7000	3200	4000	4500	3515	2085	9479	10229	10729	6°/6°

Note: (1) 5-6t: the free lift without backrest 380mm increased,(2) 7t: the free lift without backrest 225mm increased.

# G SERIES 5-10t

## 8.5-10t WIDE VIEW MAST

Mast model	Max fork height (mm)	Load capacity (load center 600mm)(kg)		Mast height, lowered (mm)		Service weight (kg)		Mast tilting angle $\alpha / \beta$
		CPCD85	CPCD100	CPCD85	CPCD100	CPCD85	CPCD100	
M250	2500	8500	10000	2450	2600	10721	12389	6°/12°
M270	2700	8500	10000	2550	2700	10775	12429	6°/12°
M300	3000	8500	10000	2700	2850	11400	12510	6°/12°
M330	3300	8500	10000	2850	3000	11501	12558	6°/12°
M350	3500	8500	10000	2950	3100	11646	12603	6°/12°
M375	3750	8500	10000	3075	3225	11726	12653	6°/12°
M400	4000	8500	10000	3250	3400	11901	12793	6°/12°
M425	4250	8500	10000	3375	3525	12056	12848	6°/12°
M450	4500	8500	10000	3500	3650	12176	12898	6°/12°
M475	4750	8200	10000	3625	3775	12321	12955	6°/6°
M500	5000	8200	10000	3750	3900	12436	13010	6°/6°
M550	5500	7850	9000	4050	4200	12758	13311	6°/6°
M600	6000	7400	8000	4300	4450	12961	13361	6°/6°

## 8.5-10t WIDE VIEW FULL FREE 2-STAGE MAST

Mast model	Max fork height (mm)	Load capacity (load center 600mm)(kg)		Mast height, lowered (mm)		Free lift (with backrest) (mm)		Service weight (kg)		Mast tilting angle $\alpha / \beta$
		CPCD85	CPCD100	CPCD85	CPCD100	CPCD85	CPCD100	CPCD85	CPCD100	
ZM250	2500	8500	10000	2450	2600	1090	1302	11447	12371	6°/12°
ZM270	2700	8500	10000	2550	2700	1190	1402	11473	12399	6°/12°
ZM300	3000	8500	10000	2700	2850	1340	1552	11515	12442	6°/12°
ZM330	3300	8500	10000	2850	3000	1490	1702	11556	12470	6°/12°
ZM350	3500	8500	10000	2950	3100	1590	1802	11584	12513	6°/12°
ZM375	3750	8500	10000	3075	3225	1715	1927	11619	12556	6°/12°
ZM400	4000	8500	10000	3250	3400	1890	2102	11756	12584	6°/12°
ZM425	4250	8500	10000	3375	3525	2015	2227	11790	12619	6°/12°
ZM450	4500	8500	10000	3500	3650	2140	2352	11825	12765	6°/12°
ZM475	4750	8200	9500	3625	3775	2265	2477	11860	12800	6°/6°
ZM500	5000	8200	9500	3750	3900	2390	2602	11865	12837	6°/6°
ZM550	5500	7850	-	4050	4200	2690	-	12067	12873	6°/6°
ZM600	6000	7400	-	4300	4450	2940	-	12136	12908	6°/6°

Note: (1) 8.5t: the free lift without backrest 222mm increased, (2) 10t: free lift without backrest.

## 8.5-10t WIDE VIEW FULL FREE 3-STAGE MAST

Mast model	Max fork height (mm)	Load capacity (load center 600mm)(kg)		Mast height, lowered (mm)		Free lift (with backrest) (mm)		Service weight (kg)		Mast tilting angle $\alpha / \beta$
		CPCD85	CPCD100	CPCD85	CPCD100	CPCD85	CPCD100	CPCD85	CPCD100	
ZSM360	3600	7500	8000	2450	2570	1090	1150	12041	13246	6°/12°
ZSM400	4000	7500	8000	2575	2700	1215	1280	12112	13338	6°/12°
ZSM435	4350	7500	8000	2700	2820	1340	1400	12186	13418	6°/12°
ZSM450	4500	7500	8000	2750	2870	1390	1450	12213	13458	6°/6°
ZSM480	4800	7200	7500	2850	2970	1490	1550	12274	13526	6°/6°
ZSM500	5000	7200	7500	2950	3035	1590	1615	12330	13572	6°/6°
ZSM540	5400	6800	7000	3075	3225	1715	1805	12404	13706	6°/6°
ZSM600	6000	6300	6500	3375	3425	2015	2005	12575	13846	6°/6°
ZSM650	6500	5700	6000	3600	3590	2240	2170	12705	13964	6°/6°
ZSM700	7000	5000	5200	3750	3855	2390	2435	12793	14142	6°/6°

Note: (1) 8.5t: the free lift without backrest 172mm increased, (2) 10t: free lift without backrest,

Note: The service weight in the table is the weight of the truck assembled with Xichai engine.

Reliable special designed instrument

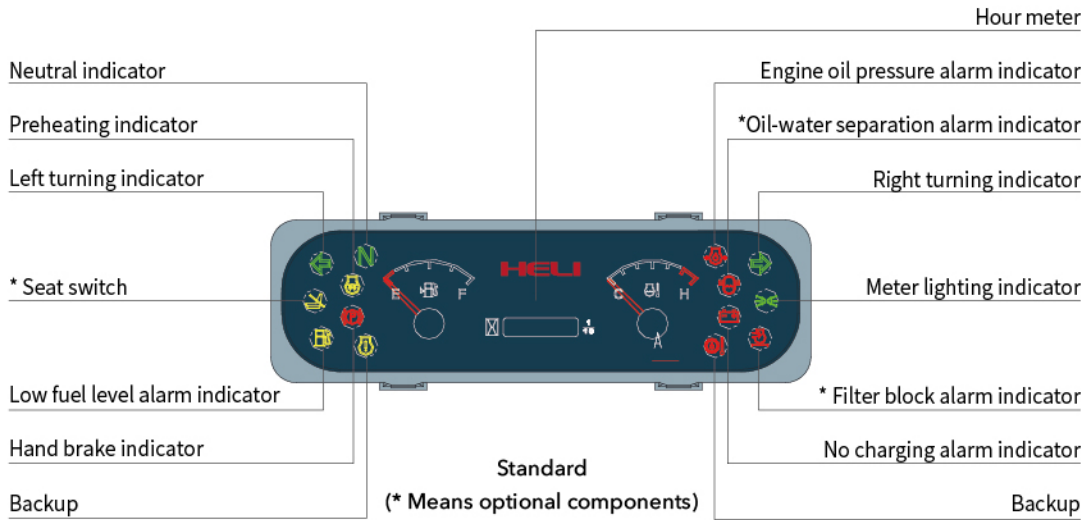

■ Reliable special meter display the whole truck' s working condition, fault detect and other important information completely which make the operator master the whole truck condition directly and conveniently.

Standard configuration		Optional	
Hour meter	Overhead guard	Driver' s cab	User-specified color
Horn	Standard fork	Warning light	Optional attachments
Oil pressure alarm	Neutral gear switch	High air exhausting device	Sling
Control valve	Hydraulic circuit oil filter	Double air cleaner	Full LED light ass' y
Wholly hydraulic-powered steering	Electro-hydraulic changing-over	Suspension seat	Power switch
Rubber pad	Intelligent shift	Fork extension	Reversing voice speaker
Backrest	Speed-limiting valve	Heater	Universal key
Rear view mirror	Oil level gauge	Solid tyre	Overspeed 10km/h alarm
Front combined lamp (LED light)	Charging indicator	Widen fork carriage	Electric fan
Transmission oil filter	Wide view mast	Wind shield	OPS(Travelling function and loading function)
Engine flame out device	Air intaking device	Purifying muffler	Drive axle with wet disc type brak
Ratchet type parking brake	Durable tire with decorative pattern	Fire extinguisher muffler	
Water temperature meter	Lifting and tilting operating handles	Fire extinguisher	
Driver' s tools	Traction pin	Rear working light	
Rear combined lamp(LED)	Semi-suspension seat	Air conditioner (certain type)	
Reversing buzzer	Hydraulic oil dipstick	OPS (travelling function)	
Tilt-lock valve	Overhead guard rain cover	Torque converter oil temperature meter	
Tilt adjustable steering column	Torque converter oil dipstick	Tilting cylinder sleeve	
Back view mirror	Combined instrument	Steering cylinder sleeve	



**ANHUI HELI CO., LTD.**

Add / No.668, FangXing Road, Hefei, China  
 Fax / +86-551-63639966  
 Tel / +86-551-63639068(America); 63639258(Europe); 63639358(Asia);  
 63662105(Africa & Middle East); 63639530(Overseas Marketing)



LinkedIn



YouTube



Facebook

\* Our products are subject to improvements and changes without notice.